



UNIVERSITY of
RWANDA

COLLEGE OF SCIENCE AND TECHNOLOGY



Website: www.aceiot.ur.ac.rw

Mail: aceiot@ur.ac.rw

AFRICAN CENTER OF EXCELLENCE IN INTERNET OF THINGS

MASTER THESIS

**DESIGNING A HEALTH ASSESSMENT SYSTEM FOR THE QUALITY
OF NAPIER LEAVES FOR ANIMAL FEEDING IN RWANDA**

*A thesis submitted in partial fulfilment of the requirements
for the award of Master of science degree in Internet of Things:
in the Wireless Intelligent Sensor Networking*

Submitted By:

Ramadhan Said Omar

Reference. No: 221028902

Submission Date: December 2022



UNIVERSITY of
RWANDA

COLLEGE OF SCIENCE AND TECHNOLOGY



Website: www.aceiot.ur.ac.rw

Mail: aceiot@ur.ac.rw

AFRICAN CENTER OF EXCELLENCE IN INTERNET OF THINGS

MASTER THESIS

DESIGNING A HEALTH ASSESSMENT SYSTEM FOR THE QUALITY OF NAPIER LEAVES FOR ANIMAL FEEDING IN RWANDA

*A dissertation submitted in partial fulfilment of the requirements for the award of Master of
science degree in Internet of Things: in the Wireless Intelligent Sensor Networking*

Submitted By:

Ramadhan Said Omar

Reference. No: 221028902

Author:

Ramadhan Said Omar

Reference. No: 221028902

Supervisors:

Dr RWIGEMA James

Prof Richard Musabe

Submission Date: December 2022

DECLARATION

I, **Ramadhan Said Omar**, a master's Student in degree of Internet of things of Wireless Intelligent Sensor Networking from Africa Centre of Excellence in Internet of things, at University of Rwanda. I declare that the content in this document is the original work and has never been presented or submitted for any academic award in any university or other institutions of higher learning as a whole or in part of work. I also declare that, as required by rules I have fully cited and referenced all material and results that are not original to this work.

Ramadhan Said Omar,

221028902

Signed

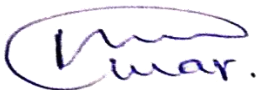

.....
Date: 20th December 2022

Master's Degree, African Centre of Excellence in the Internet of Things,
College of Science and Technology, University of Rwanda.

Wireless Intelligent Sensor Network (WISeNeT)

BONAFIDE CERTIFICATE

This is to certify that the dissertation report work titled “**Designing a health assessment system for the quality of leaves for animal feeding**” is the bonified original work done by Mr. **Ramadhan Said Omar, Ref. 221028902**, a post-graduate student in MSc in the Internet of Things with a specialization in wireless Intelligent Sensor Networking (WISeNet) at the University of Rwanda, College of Science and Technology in African Center of Excellence in the Internet of Things (ACEIoT), the Academic year 2020/2021. We certify that the work reported does not form a part of any other research project. This work has been submitted under the supervision of *Dr. RWIGEMA James* and *Professor Richard Musabe*.

Main Supervisors:

Co-Supervisors:

Dr RWIGEMA James

Prof Richard Musabe

Signed: _____

Signed: _____

Date: December 20, 2022.

Date: December 20, 2022

The Head of Master’s and Training, ACEIoT, University of Rwanda.

Dr RWIGEMA James,

Signed: _____

Date: December 20, 2022

DEDICATION

I dedicate this thesis report document to my supervisors, for their empathy and friendly assistance during my research period, to my lecturers who encourage me always to work hard in academics, and who pray for me unceasingly.

ACKNOWLEDGMENTS

First of all, I would like to thank the Almighty God, who gave me the grace to accomplish this work. I would like to express my sincere and special thanks to my supervisors Dr RWIGEMA James and Prof Richard Musabe, for their great guidance and supervision in the achievement of this work from which I gained invaluable knowledge, and again to the Director of the center Professor Damien HANYURWIMFURA, Head of Masters' studies Dr RWIGEMA James and Postgraduate & Research Administrator, Mr. BENJAMIN Hakizimana. Secondly, I wish to thank the African Center of Excellence in the Internet of Things, College of Science and Technology, University of Rwanda, the whole management, and its staff who directed, advised and helped me gain knowledge of IoT during my school day. I also wish to thank my family members who have done great sacrifices by providing me with all the necessary means to have a good education. Thirdly, I thank my classmates, especially those who were together in groups in all academic activities for their direct and indirect contributions to the achievement of my objectives. Lastly, my appreciation goes to the lecturers on the Internet of Things for the good job done during my career of 2 years of our courses. My acknowledgment goes to everyone who supported me in my everyday life to reach this accomplishment.

May the Almighty God bless you all.

ABSTRACT

Livestock keeping is considered one of the main sources of both domestic and commercial products which plays a crucial role in the household and national economies in the respective country of Rwanda. The lack of equipment to monitor the quality of the best environment for animals makes animal caregivers continue to use local methods in their livestock-keeping activities. This leads to an increase in outbreaks of diseases in animals and makes its products decrease its quality in the market. With the current improvement in the development of the Internet of Things in the agricultural sector, the Internet of Thing Animal Healthcare (IoTAH) using the spread of computing is considered a fundamental approach through sensing and actuating technologies in assessing animal health. IoT devices in different forms such as wearable devices, sensors deployed units, and Unmanned Aircraft Vehicle (UAV) moving devices have been used to track the stimuli of husbandry activities, thus present a gap in precision to manage health assessment parameters of the quality of Napier leaves for animal food.

Internet of things (IoT) nowadays is based on the smart farming system as a solution for monitoring animals. This involves IoT-based technologies to enable farmers to control animals based on such as movement control, weather detection, disease detection, and other parameters of treating those animals such as the safety of clean water.

Within the previous research, the use of sensors in animal investments has not sufficiently provided the optimized solution for better food selection for animals to be improved. Therefore, there is still a need to improve the existing methods of examining the quality of leaves that can give animals

better health. which is an important need, and the system could be able to help collect data to support future studies processing and optimize decision-making.

In this research work, we introduce a Quality-Leaf-IoT Assessment System (QLIAS) for examining the quality of leaves for the best animal feed. Firstly, the primary intention of QLIAS is to evaluate the quality of the leaves, based on the basic colour of Red, Green, and Blue (RGB) appearance using a colour sensor to assess the solid colour of the leaf. Secondly, QLIAS will track the weather level in the leaf nest areas to check the possible source of the bad growth of the leaves. In addition, we will develop a Leave-Pack Quality Accessing Kit (LPQAK) a portable kit mounted with sensors, the low-cost best tool, and easy to use in assessing the quality leaves. LPQAK will be the best-fit tool for collecting Napier leaves parameters and storing data in the cloud platform. Furthermore, the tool is configured with an Machine Learning (ML) model and gives results of an assessed leave of Full nutritional, moderate, and unhealthy leaves.

TABLE OF CONTENT

DECLARATION	ii
DEDICATION	iv
ACKNOWLEDGMENTS	v
ABSTRACT.....	vi
TABLE OF CONTENT	viii
LIST OF TABLES	xii
LIST OF FIGURES	xiii
LIST OF SYMBOLS, ABBREVIATIONS, AND NOMENCLATURE	xv
CHAPTER I: GENERAL INTRODUCTION.....	1
1.1 OVERVIEW AND BACKGROUND.....	1
1.2 BACKGROUND, TARGET AREA, AND MOTIVATIONS OF THE STUDY	3
1.2.1 BACKGROUND OF THE STUDY	3
1.2.2 TARGETED AREA AND PROJECT OVERVIEW	4
1.2.3 A POSSIBLE OUTBREAK OF DISEASE AND ITS EFFECTS	5
1.3 PROBLEM STATEMENT	6
1.4 STUDY AIM AND OBJECTIVES.....	7
1.4.1 AIM OF THE STUDY.....	7
1.4.2 OBJECTIVE OF THE STUDY	8
1.5 HYPOTHESES OF THE STUDY	8
1.6 THE SCOPE OF THE STUDY	8
1.7 SIGNIFICANCE OF THE STUDY	9
1.8 ORGANIZATION OF THE STUDY	10
1.9 CONCLUSION	11
CHAPTER II: LITERATURE REVIEW	12

2.1	INTRODUCTION.....	12
2.2	NAPIER LEAF DISEASE DETECTION.....	12
2.3	CONVENTIONAL TECHNIQUES FOR NAPIER LEAF QUALITY DETECTION.	13
2.3.1	THE MANUAL LAB TECHNIQUES	13
2.3.2	LAB IN CHIP TECHNOLOGY.....	13
2.4	ML NAPIER LEAF QUALITY MEASUREMENT	14
2.5	THE SUMMARY AND GAP IDENTIFIED	15
2.6	CONCLUSION	16
CHAPTER III: RESEARCH METHODOLOGY		17
3.1	INTRODUCTION.....	17
3.1.1	RESEARCH PROCESS VIEW MAP	17
3.1.2	RESEARCH APPROACH PROCESSING.....	18
3.2	MACHINE LEARNING (ML) PROCESS.....	18
3.2.1	TECHNOLOGIES USED TO DEVELOP OUR STUDY	19
3.3	SYNTHETIC DATA METHOD OF DATA GENERATION APPROACH	20
3.4	DIGITAL SIGNAL PROCESSING	21
3.5	DATASET AND ML DATA TRAINING.....	22
3.6	SYSTEM DESIGN METHOD	23
3.7	CONCLUSION	23
CHAPTER IV: SYSTEM ANALYSIS AND DESIGN		24
4.1	INTRODUCTION	24
4.2	SYSTEM ARCHITECTURE	24
4.2.1	HIGH LEVEL SYSTEM ARCHITECTURE.....	24
4.2.2	IOT SYSTEM ARCHITECTURE.....	25
4.2.3	THE THREE-LAYERED-NETWORK ARCHITECTURE DETAILED	26

4.3	EMBEDDED SYSTEM LEVEL DESIGN.....	27
4.3.1	SYSTEM BLOCK DIAGRAM	27
4.4	SYSTEM REQUIREMENTS AND SPECIFICATIONS.....	28
4.4.1	HARDWARE REQUIREMENTS AND SPECIFICATIONS	28
4.4.2	HARDWARE CAPACITY SPECIFICATIONS.....	29
4.5	THE SYSTEM DESIGN FLOWCHART, PROGRAM DESCRIPTION LANGUAGE (PDL)33	
4.6	EDGE IMPULSE ML FUNCTIONALITY PERFORMANCE	35
4.7	HW/SW EMBEDDED SIMULATION	35
4.8	HARDWARE SET-UP	37
4.8.1	MIND MAP OF THE QLIAS PROTOTYPE	37
4.8.2	HARDWARE SET-UP.....	37
4.9	CONCLUSION	40
CHAPTER V: SYSTEM RESULT AND ANALYSIS.....		41
5.1	INTRODUCTION	41
5.1.1	LPQAK FOR NAPIER LEAF DATA COLLECTION.....	41
5.1.2	DATA SEQUENCE AND CORRELATED	42
5.2	ML MODEL.....	43
5.2.1	NAPIER LEAF DATASET.....	43
5.3	MACHINE LEARNING DATA TRAINING	45
5.3.1	ML POSSIBLE TECHNIQUES.....	45
5.3.2	ML DATA PERFORMANCE BEFORE TRAINING	46
5.4	MACHINE LEARNING DATA TRAINING	46
5.4.1	SYNTHETIC DATA GENERATION RESULTS	48
5.5	RESULT PERFORMANCE OF THE PROJECT INFERENCE	48

5.6	RESULT DISCUSSION OF ACCURACY PERFORMANCE	49
5.7	DIFFERENCES IN DATA PERFORMANCE INFERENCES IN TESTING MODEL ON SIMULATION TOOLS AND THE ACTUAL DEVICE BOARD OPERATION	50
5.8	CONCLUSION	52
CHAPTER VI: CONCLUSION AND RECOMMENDATIONS		53
6.1	CONCLUSION	53
6.2	RECOMMENDATIONS AND THE FUTURE WORK	54
REFERENCES		55
APPENDICES		59
Appendix	1: Project programming codes on ML testing data	59

LIST OF TABLES

Table 1: Various applications and technologies used in plants healthcare	15
Table 2: Presents: Selected sensor types and IoT main components, technologies used, and the details of their uses.....	29

LIST OF FIGURES

Figure 1: Map which shows the location of Nyagatare where the study was taken	5
Figure 2: Study proposed process	17
Figure 3: ML tool Stack, structure used to process data training in the ML	20
Figure 4: The initial starting point of the ML processing in Edge Impulse.....	22
Figure 5: The high-level system development of the QLIAS.....	25
Figure 6: Network Architecture considered on the project development	26
Figure 7: The system block diagram.....	28
Figure 8: The TCS3200 color sensor with a specific description represented by a, b, c, and d. ..	31
Figure 9: The Arduino Nano BLE 33 with a specific descriptions a, b, and c.	32
Figure 10: Flowchart of the system	33
Figure 11: PDL System functionality main and sub program represented in a, b, c, d and e.....	34
Figure 12: The Hardware and Software Embedded Simulation	35
Figure 13: The Hardware and Software Schematic Simulation.....	36
Figure 14: The mind map of the Hardware Sensor tools	37
Figure 15: Embedded devices setup	38
Figure 16: The communication module setup	38
Figure 17: ThingSpeak Cloud based store Napier leave data	41
Figure 18: MATLAB Visualization of stored data in cloud.....	42
Figure 19: Napier Leaf Full Nutrition (Health leave).....	44
Figure 20: Napier Leaf Moderate Nutrition.....	44
Figure 21: Unhealth Napier Leaf	44

Figure 22: The nature of the data before ML training process started..... 46

Figure 23: Edge Impulse actual Hardware performance during ML processing..... 47

Figure 24: Generated synthetic data after training..... 48

Figure 25: Synthetic data model confusion matrix Accuracy performance 49

Figure 26: Synthetic differences on data testing performance..... 50

Figure 27: Testing data sample results..... 51

Figure 28: Static Buffer from library created by the edge impulse display 99% of the tested data
in the actual device..... 52

LIST OF SYMBOLS, ABBREVIATIONS, AND NOMENCLATURE

ACEIoT	:	African Center of Excellence in Internet of Things
AI-IIS	:	Artificial Intelligence-Integrated IoT Solution
ASYL	:	African Sugarcane Yellow Leaf
BA	:	Beta Agonist
BGWL	:	Bermuda Grass White Leaf
Dr	:	Doctor
EA	:	East Africa
EDPRS	:	Economic Development and Poverty Reduction Strategy
ESP8266	:	Espressif Systems
EWMA	:	Exponential Weighted Moving Average
FAO	:	UN Food and Agriculture Organization
i2C	:	Inter-Integrated Circuit
IA	:	Industrial Attachment
IoT	:	Internet of Things
IoTAH	:	Internet of Thing Animal Healthcare
LED	:	Light Emitting Diode
LPQAK	:	Leave-Pack Quality Accessing Kit
MINAGRI	:	Ministry of Agriculture and Animal Resources
MINICOM	:	Ministry of Trade and Industry and Industry
NDS	:	National dairy Strategy
NGDP	:	National Gross Domestic Product

NGS	:	Napier Grass Stunt
NodeMCU	:	Node Micro Controller Unit
PMS	:	Plant Monitoring System
PRMS	:	Plant Remote Monitoring System
QLIAS	:	Quality-Leaf-IoT Assessment System
RGB	:	Red, Green, and Blue (
RSYB	:	Rwanda Statistical Yearbook
RYD	:	Rice Yellow Dwarf
SDGs	:	Sustainable Development Goals
SVM	:	Support Vector Model
UAV	:	Unmanned Aircraft Vehicle
Wi-Fi	:	Wireless Fidelity
WISENeT	:	Wireless Intelligent Sensor Networking

CHAPTER I: GENERAL INTRODUCTION

1.1 OVERVIEW AND BACKGROUND

Rwanda is a country that has been very successful in improving animal husbandry through various empowerment projects. Livestock keeping is one of the activities that are dependent on the country of Rwanda which contributes 8.8% of the 40% to the National Gross Domestic Product (NGDP)^[1]. Livestock keeping is also one of the ancient economic activities that traditionally provide the people of Rwanda products such as leather, meat, and milk. Livestock keeping also provides manure that is used in agriculture as plant fertilizer which leads to improving the agricultural sector in Rwanda, for example, the cultivation of crops such as millet, maize, and beans. The contribution of livestock keeping was contributing to the country's income at the rate of \$23,679,907 annually from the export of live animals^[2] as explained by Rwanda Statistical Yearbook (RSYB) 2015.

However, livestock has limitations and challenges related to existing infrastructure, fermentation process and technology. Poor infrastructure of the way to verify food supply (e.g., the quality of leaves), the collection of essential data for feeding information (e.g., daily records of the development of quality leaves for pasture) and having the right storage of the food for dry seasons (e.g., dry leaves storage) prevent the growth of production in large-scale farms. Farmers are burdened by paying a large amount of money to treat their livestock's regularly and this is a major challenge facing this type of agriculture. There is also a lack of alternative methods to monitor the quality of livestock fodder which causes farmers to produce substandard products or leads to low availability of products such as milk.

Animal feed is very important for bringing the quality of animal products. The safety of animal feeds is very important to elude contaminations and diseases ^[3], Poisonous chemicals frequently found in animal foods such as Beta Agonist (BA), Dioxin, Nitrofurans, Chloramphenicol, and Fluroquinolone could accumulate in the animal body and be transmitted to their own product such as milk, skins, meat, and offal. The demand for animal feed is increasing day to day according to the growth of the animal husbandry sector in Rwanda and its use is necessary. However, many animal breeders do not have enough land to grow good pastures for their animals. Farmers require a lot of manpower for monitoring the farms.

The need to reduce the problems of good growth of animals for commercial income and food has been a very important consideration, the community, the country, and last but not least the whole nation always depends on the quality of the product for building a better life for people. For decades, various problems facing animals have been reported along with their causes, the UN Food and Agriculture Organization (FAO) report in ^[4] identifies that the food eaten by animals is a primary source of 63%, while data continue to clarify that climate change took 17%, either in the food production area or in the areas where the animals are kept and other elements which is 20%, are parts of the source of the animals getting sick ^[4]. The major challenges facing livestock keeping in Rwanda are caused by the existence of all three main conditions as defined by various researchers.

IoT is one of the most revolutionary technologies solutions in modern wireless communications enabling the system to be well organized ^{[5][6]}. QLIAS means that it is a model that will enable the assessment of the quality of leaves for animal feed. The main purpose of this study is to design an

IoT health assessment system for recognize the quality of Napier leaves for animal feeding in Rwanda. In this paper, the real-time investigation technique is proposed. QLIAS will be analyzing the characteristics of the quality leave as well as the level of the weather, and last but not least it will give a result of the assessed leaves, and furthermore will provide the data for the future use. The result of the data analysis of the performance of the QLIAS system will use the MATLAB an online ML of EDGE IMPULSE investigation simulation tool. The simulation and schematic diagrams will be developed by using FRITZING open source simulation app. The research practices will be taken at the side of Nyagatare District, Eastern Region in Rwanda.

1.2 BACKGROUND, TARGET AREA, AND MOTIVATIONS OF THE STUDY

1.2.1 BACKGROUND OF THE STUDY

The continuation of increasing poisonous chemicals frequently found in animal foods such as Beta Agonist (BA), Dioxin, Nitrofurans, Chloramphenicol, and Fluoroquinolone still accumulate in the animal body and be transmitted to their own product such as milk, meat, and offal. FAO insight that for decades, and various problems facing animals have been reported along with their causes, the report identifies that the food eaten by animals is a primary source of 63%, while data continue to clarify that climate change took 17%, and other issue led to 20% ^[4]. Farmers are still burdened by paying a large amount of money to treat their livestock regularly and this is a significant challenge facing livestock-keeping activities in the whole sub-Saharan African countries. The incidence of death of animals increases, losing animal weight, and stagnation in producing milk, due to the lack of farmers who could not manage to feed their animals better and good quality food. Currently, Napier grass is one of the most and best food for animals in most east African countries. However, the level of preparedness of the health center for animals in Africa shows

many weaknesses expressed in the small number of facilities in rural settlements ^[7]. So, most victims of animal outbreak diseases are in large capacity in rural areas. This shows the limited capacity in sub-Saharan Africa in monitoring animal food victims is not an issue of efficiency and is not done in a timely manner.

1.2.2 TARGETED AREA AND PROJECT OVERVIEW

Plants in ^[8], plays an essential role in conserving the ecological cycle and maintaining the pyramid of the food chain. This research has been carried out on cattle breeding in Nyagatare District, Eastern Region of Rwanda, an area where most of the residents are cattle caregivers. The type of studies conducted in this area with the size of farms from 6.5 ± 0.8 hectares, which classified the main type of animal food and potential areas, from ^[9] it has been found that the main type of animal food is Napier grass which is. 93.2% is grown for animal feed.

However, the study did not identify alternative methods for supervising Napier grass leaves. Meanwhile, livestock in Rwanda is one of the pillars of economic growth as well as poverty reduction, as the Economic Development and Poverty Reduction Strategy (EDPRS) as describes ^[10]. In this sense, Figure 1 presents the location map specific in Rwanda where livestock activities are practiced, and our research done.

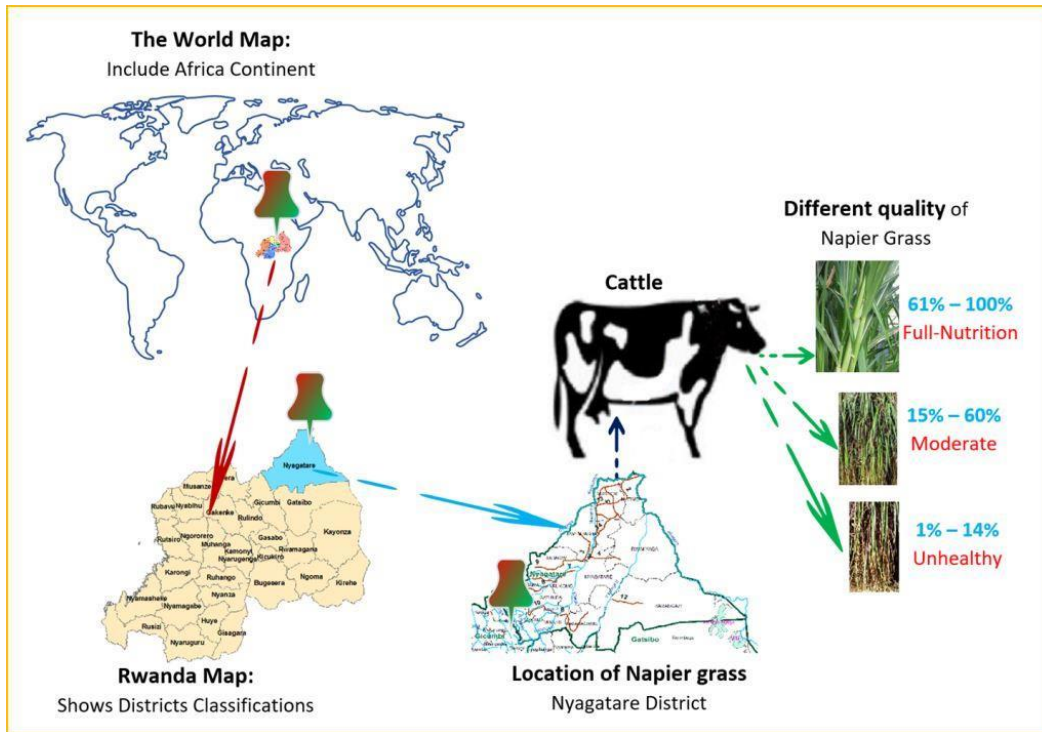

Figure 1: Map which shows the location of Nyagatare where the study was taken

1.2.3 A POSSIBLE OUTBREAK OF DISEASE AND ITS EFFECTS

The Napier or Elephant grass (*Pennisetum Purpureum* Schumacher) constitutes between 40 and 80% of forages in East Africa where it is used by smallholder dairy farmers in intensive (zero-grazing) and semi-intensive dairy cattle production systems ^[11]. Despite Napier grass being a great food for animals, there is still a great use of these leaves such as the conservation of soil and water clean-up protection in highly slope areas, planted as a crop border, it is also used as a trap plant in the management of cereal stem borers ^[12]. Among the major diseases reported to attack Napier grass is known as Napier grass stunt disease. Napier grass stunt (NGS) disease is caused by a phytoplasma, a cell wall-less bacterium of the genus 'Candidatus (Ca) Phytoplasma (Class - Mollicutes; order - Acholeplasmas) ^[13]. NGS diseases also attack crops such as maize, rice 'rice yellow dwarf (RYD)', sugarcane 'African sugarcane yellow leaf (ASYL)', and other wild grasses 'e.g., Bermuda grass white leaf (BGWL)' in the East African region.

The NGS symptoms manifest in the re-plant gray-colored of Napier grass plants after cutting or grazing. In ^[14] has confirmed the primary means of NGS spread is through the introduction of infected cuttings by farmers or re-planting of affected seeds, or through insect vectors (grasshopper) carrying the phytoplasma. Last but not least, NGS is also exasperated by poor soil conditions and poor management of weeds in addition to poor harvesting of the plant, ^[14] continue to insight. The efforts taken to solve the problem of the disease are, in ^[15] which has pointed out that previous studies have focused mainly on the farmer's knowledge and perception of NGS.

1.3 PROBLEM STATEMENT

Rwanda does not have a livestock master plan, but there is a National Dairy Strategy (NDS) of which the main stakeholder are the Ministry of Agriculture and Animal Resources (MINAGRI) and the Ministry of Trade and Industry and Industry (MINICOM). So far, they have not been able to invest their plans in the quality of animal food production. The NDS develops targets for milk production, a marketing system, and a policy environment and institutional framework ^[16]. This situation can be a root cause of increasing of speed of outbreaking diseases and even unnecessary death to the animal. The existing method for Napier leave quality analysis methods are using the Internet of things which involves the use of interconnection of devices, and objects focus on the prevention of the invasion of poisonous, and therefor lack a way to link assessment of the quality of leave is the big challenges. Improvements have been implemented on existing IoT-based leave quality disease detection infrastructure with the combination of IoT and ML. The current solutions are based on developing to design a health assessment system for the quality of Napier leaves for animal feeding in Rwanda. Furthermore, there is no mechanism for data creation and data storage

of the real-time assessment. Of course, those solutions are not practical for mass deployment in all local livestock plantation as a way to notify users in real-time about the necessary problems of food with its effect before they feed their animals. Currently, all study of leaves the experiments ran manually with laboratories and involve skilled staff to carefully drive all processes.

It is therefore real-time necessary to detect the quality of Napier grass and create data to store on the server is needed. This creates a need for the device itself to perform quality analysis of the Napier grass quality for the end user. Thus, ML is most useful as it reduces the need for human processing and processes quick results from the user's perspective. Hence enable to prevent and mitigate these poisonous and outbreak of the animals' diseases data accuracy should be concerned.

1.4 STUDY AIM AND OBJECTIVES

1.4.1 AIM OF THE STUDY

The aim of this research is to develop the best-fit tool kit that enable day-to-day easy and cheap, unskilled Napier leaf quality detection for every livestock keeper everywhere at any time to enable them to have a determination assessment of the ingredient of the animal food. This aim will be achieved through prototyping leave detector tools for assessing the quality of Napier grass relying on open-source IoT and ML technology. Furthermore, the aim of this project line with the Sustainable Development Goals (SDGs) *goal 2 End hunger*, which lead to achieve food security and improved nutrition and promote sustainable agriculture. This study aims at a quick and real-time detection of the Napier leaf gradients to prevent the increase of outbreak diseases and avoid unnecessary animal deaths.

1.4.2 OBJECTIVE OF THE STUDY

The effectiveness of positive results of this research aims to achieve the following objectives:

- a) To understand how Napier grass outbreak disease can be detected from color detection technology.
- b) To identify an IoT technology that is suitable for sensing, tracking, transmitting, and keeping processing of the Napier grass gradients.
- c) To understand how the local Napier grass plantation process are limited in the today needs of the animal food production process.
- d) To design and simulate a smart IoT Machine Learning assessment tool for the quality of Napier leave.

1.5 HYPOTHESES OF THE STUDY

The hypothesis of this research are as follows:

- 1) The current IoT sensing technologies can efficiently collect Napier characteristics and observing the best nutrition for the best food of animals.
- 2) Integration of IoT and ML can be leveraged to detect the sign of affected Napier grass and ensure the target level of its quality.
- 3) There is available technology that could be used to create ML models capable of Napier grass data processing.

1.6 THE SCOPE OF THE STUDY

Due to the limitation of resources, limitation of availability of datasets for the training of ML Model for Napier grass, and limitation of skills to process quality leave process, this study was

evaluated on the assessing of Napier grass quality based on created datasets and synthetically generated data through the developed tool kit.

1.7 SIGNIFICANCE OF THE STUDY

Methods to recognize the outbreak disease in Napier grass is very poor, especially in African countries. Many thanks to the presence of technology of IoT, a technology that is user-friendly, does not cost a lot, and does not waste time, which can help to detect, and report the gradients in quality of Napier grass and store to cloud platforms. Hopefully the idea developed will help livestock caregiver to understand the nature the animal food before they decided to feed their animals and help necessary mitigation and preventing measure will be decided by the caregiver him/herself.

Napier grass is a great food for animals raised in sub-Saharan Africa and thrives especially in East Africa. Not many years passed before the importance of Napier grass became known as an important food for animals in Rwanda. The operations of Napier grass cultivation are currently at a low level and no measures have been taken to verify the effectiveness of Napier grass cultivation. The quality of Napier grass varies from one process to another process depending on the attention of the livestock caregivers themselves. Furthermore, in Rwanda, there is no scientific studies have been done for Napier grass on assessing the gradients of Napier grass which occurs during the production process. So, the possibility of increasing the effects of animal disease is large. Therefore, a solution that can report consistently will be given a more accurate epidemiological view.

Despite of increasing level of the outbreak of disease led by the bad leave fermentation and processing of Napier grass, the possibility of mitigating the current situation is quite possible. This project can help the overall not only Rwanda, but also other African neighbouring countries set to keep animals healthier and minimize the death rate and minimize the frequent treatment of animals through early detection techniques and monitoring the Napier grass quality.

1.8 ORGANIZATION OF THE STUDY

This work is organized into five chapters:

- **Chapter I:** General Introduction, this chapter focuses on the Aim and Objectives of the study, the Problem statement, the Hypothesis, the Scope of the study, and the Significance highlighting the potential impact.
- **Chapter II:** The Literature review, offers theoretical concepts regarding the related work done by the other researchers.
- **Chapter III:** Research Methodology, this chapter will illustrate the main concepts of this study.
- **Chapter IV:** System Analyze and Design, this chapter will show the designing techniques and discuss all necessary requirement tools used of the study.
- **Chapter V:** System Result and Analysis, will focuses on the results of the study and discussions.
- **Chapter V:** The last chapter is made up of the Conclusion and Recommendations for further improvements of this project.

1.9 CONCLUSION

In this chapter, a brief description of the project has been started that introduces the setting and background. Furthermore, the aim and objectives of the study are illustrated. The problem statement, the scope of the studies, highlights what is to be overcome and proposed techniques and technologies that will be used in the prototype in accordance with the assumptions the project is planning to achieve at the end of design and implementation. The related works and literature reviews are detailed in the coming chapter.

CHAPTER II: LITERATURE REVIEW

2.1 INTRODUCTION

This chapter illustrates and discusses in depth the relevant studies, reaches and state of the art used technologies done by the other researchers, individuals, and stakeholders in the field and provides an overview, insights and usefulness of existing technologies that have been used to drive our approach to a solution towards quality leaves health assessment detection using ML. The literature review is basically organized as follow; firstly, presenting the situation of Napier grass disease detection and relate technology used, secondly, presenting conventional techniques for Napier leaf quality detection, and lastly a quick state of the art of using ML for Napier Quality measurement. Moreover, the summary and identified gap is described.

2.2 NAPIER LEAF DISEASE DETECTION

The Internet of Things Animal Healthcare (IoTAH) is an approach that uses biosensors and software for monitoring and maintaining animal health records ^[16]. This type of technology makes a precise health status and sickness projection only to human and has not been applied yet to animals or to plants used as food for animal. The basic principle of IoTAH is to collect different data of disease indicators from animals caused by various causes. If symptoms of the disease are detected, treatment measures are taken manually. The sample (stimuli) is sent to the laboratory and investigated manually. If the stimuli give a negative result, it is considered that there is no bad effect, and the system does not suggest conducting another examination for other areas. IoTAH offers many advantages in predicting the type of disease; however, the major difficulty in identifying the quality of animal food IoTAH did not consider. However, many studies have confirmed that the type of data collected related to animal detection and movement prediction ^[17]

is not satisfactory. While more efforts have been put into consideration, monitoring livestock keeping on food, water, weather prediction, wind, and illumination ^[18]. It is worthwhile very crucial to keep a sharp eye on each damaged area is more important. In our case openly seemed there are more limitations of those used models such as fewer data collections, real-time performance investigation on the leaf, lack of report information, and limited models for leaf quality investigations.

2.3 CONVENTIONAL TECHNIQUES FOR NAPIER LEAF QUALITY DETECTION

2.3.1 THE MANUAL LAB TECHNIQUES

In ^{[19][20][21]} has described the challenges faced by leafy plant research. The identification of plant diseases is one of the most basic and important activities in agriculture, diagnosis is done manually, visually, or by microscopy. However, the approaches did not clearly show the results of all types of plant life studies. For example, the classification of different types of solutions for the vulnerability was not easy to be determined. In ^[22] shows that the chemical sprays on leaves however were contaminated the environment and cause major health risks to humans, livestock, and biodiversity, especially the non-targeted organism. This research was focused on treating leaves manually. The system led to the automatic system for evaluating the problems of leaves became a big challenge.

2.3.2 LAB IN CHIP TECHNOLOGY

The field of plant research has been presented as a very popular topic in different research and has been in existence for several years. Despite the fact that these topics have been found are very few due to the lack of continuation of their effectiveness. To come out with a good proper solution in agriculture based on real-time monitoring plant growth with other parameters, researchers

proposed different kinds of IoT models ^[23]. The author presents Artificial Intelligence-Integrated IoT Solution (AI-IIS) to increase the yield in crop production. The study was based on categorization in collecting data via the IoT platform and applying six ML models. The study was based on determining the parameters such as atmospheric humidity, temperature, soil moisture, soil temperature, and light intensity.

2.4 ML NAPIER LEAF QUALITY MEASUREMENT

The D. G Sean et al. ^[24] has proposed a method that uses Digital Images to identify pest disease on leaves. The model is based on types of pest detection through images that naturally took time in its process. The same to the Author ^[25] who proposed an IoT-based solution for the Plant Monitoring System (PMS) to study parameters such as temperature, humidity, and intensity of light, data were accessed by smartphone from the cloud server. Ezhilazhahi et al. in ^[26], develops the Plant Remote Monitoring System (PRMS) in improving the integration of the system with IoT technology to monitor the plant soil moisture. The primary objective of this research is to elaborate on the life of the network and algorithm used in this study to archive the outcome of the Exponential Weighted Moving Average (EWMA). In ^[27] proposed AI sensors are integrated with IoT application that helps to monitor the crop field. It was a deployed sensor platform and the sensors such as an optical sensor, an electrical sensor, and an HTE mix sensor were used. Furthermore, the author in ^[28] introduces IoT-based solutions in the plant field to classify the plant's disease and monitor real-time parameters such as air temperature, humidity, pH, soil moisture, and an update in the MySQL database. The study applies a Support Vector Model (SVM) for classifying the colour features, shape, and texture. Table 1 is a summary of the applications done in the plant assessment.

Table 1: Various applications and technologies used in plants healthcare

Applications type	Technologies used	Applications / Usefulness
AI-IIS	Atmospheric humidity, temperature, soil moisture, soil temperature, and light intensity	Determine whether parameters using Integrated IoT AI
IoT Treatment Kit	Physical Kit	Used for manual operation spray treatment kit
IoT Digital Image	Camera, light intensity, Atmospheric humidity	Identify pest disease on leaf
PMS	Temperature, humidity, the intensity of light	Monitoring plant Growth depends on whether the parameters
PRMS	Soil moisture, soil temperature	Monitoring a soil moisture
AI Crops Monitoring App	An optical sensor, an electrical sensor, an HTE mix sensor	Monitoring the Crops field

2.5 THE SUMMARY AND GAP IDENTIFIED

The State-of-the-art response to the above-mentioned problems, and due to the involving expensive, complex, high latency processes, resources, and highly skilled laboratory staff, different methods and techniques were proposed by researchers through IoT architectures, Moreover, the IoT investigation models have been utilized in various sectors including smart agriculture, smart city, smart manufacturing, smart health, smart grid, and so forth ^{[29][30][31]}. Those solutions are not practical for mass deployment on all plant leaves in East Africa (EA) as a way to warn animal caregivers in real time about a potential leaf disease.

With the success and materialization of the IoT technology, real-world physical entities could be deployed by actuating, sensing, computing, communicating, visualizing, and to some extent with some level of intelligence. IoT is one of the most revolutionary technologies solutions in modern wireless communications enabling the system to be well organized ^{[32][33]}. The Quality Leave IoT

Assessment System (QLIAS) means that it is a model that will enable the assessment of the quality of leaves for animal feed. The main purpose of this study is to design a health assessment system for the quality of Napier leaves for animal feeding in Rwanda. In this paper, the real-time investigation technique is proposed to overcome the identified above-mentioned gap. QLIAS sensed data will be transmitted to the cloud where trained ML models perform Napier leaves quality analysis (inference) to predict the best quality leaves generally or specifically against a given piece of Napier leave. The solution, for now, will be centered on the cloud for data storage and the online platform for determining inference and will be accessed via a single device through Wi-Fi internet.

Our study approach is to design and develop a prototype for Leave-Pack Quality Assessment Kit (LPQAK) using machine learning models from Red, Green, and Black (RGB) colour sensor and recording the existing weather condition of the day.

2.6 CONCLUSION

A clear gap in how the manual technique was used to analyze plant leave gradients which are not suitable especially for rural areas-based community mass deployment has been highlighted. We have seen that existing solutions still require laboratory for processing and examinations, skilled labour, and more expensive resources that cannot be feasible in resources constrained countries, especially in sub-Saharan Africa. Therefore, this study proposes using IoT technologies to capture quality parameters of leaf-to-words inference of QLIAS using ML.

CHAPTER III: RESEARCH METHODOLOGY

3.1 INTRODUCTION

This chapter is going to describe how the research will be conducted in order to achieve the planned objectives. First will present the steps undertaken the study implementation period, then followed by research techniques and tools used to facilitate the target of the project. The chapter will describe other concepts in very specific topics when needed example architecture concepts, network concepts, and technology concepts.

3.1.1 RESEARCH PROCESS VIEW MAP

The research process started after completion of one-year masters of theoretical studies. During the theoretical studies, idea creation was the main focus practically, the project proposal was initiated earlier in the second year and the first session for topic presentation was organized. Selection of the project topic and approval done on that session. In Figure 2 represents the summary of the research process in the form of PESTEL study process [56].

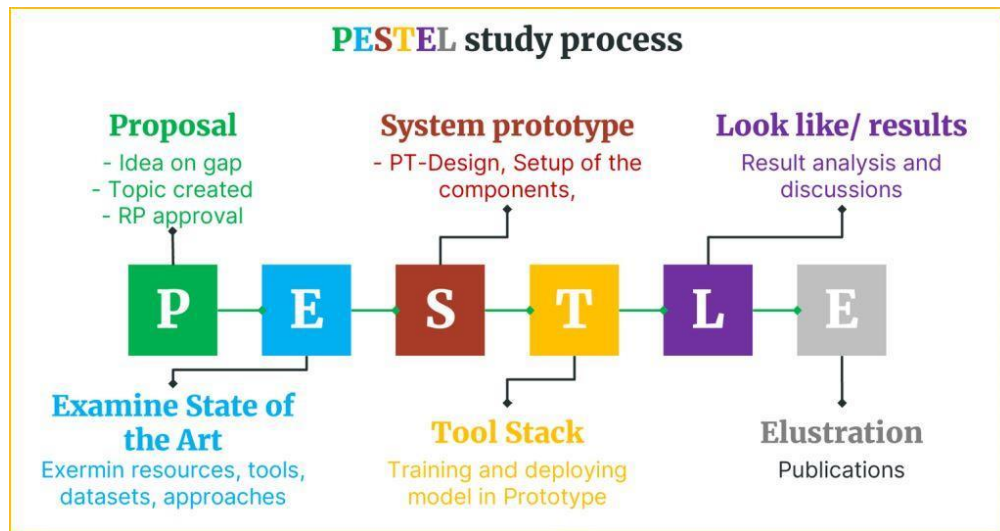

Figure 2: Study proposed process

3.1.2 RESEARCH APPROACH PROCESSING

The research approach processing based on the development of the mainstream brain storming ideas and make them to be the actual results. This section is going to explain about the way of study progress will be organized in the consideration of both hardware and software repositories. The process started on the gathering requirements, data acquisition, hardware and software co-design, hardware and software setup, evaluation, hardware and software implementation and closing with the hardware and software validation.

3.2 MACHINE LEARNING (ML) PROCESS

ML process requires a dataset for implementing data training. We are going to use a dataset created by us during the development of our prototypes, this dataset is the collected data of the Napier plant leaves by using a TS300 color sensor. The sensor collects basic RGB colors. Through the programming code the RGB color is distinguished accordingly into three main classes, *Full Nutrition leave*, *Moderate healthy leave*, and *Unhealthy leave*. The dataset will be going to use in the training process on an ML framework that can produce a model optimized for embedded processors. The created model will be packaged in the form of a software library, and after that could be integrated into our application and compiled to the targeted processor architecture. the integrated model to the device will create results and these results will be executable by deployed on either embedded simulation tool same as to the prototype board itself. The main function which is going performed is getting the validity by reading test data from a file and comparing the result accuracy with one obtained by ML.

3.2.1 TECHNOLOGIES USED TO DEVELOP OUR STUDY

The proposed technology for implementing this project is composed of the following

- a) **Edge impulse, the online open-source platform:** It is an open source that can be used for the development of ML models. It allows the direct acquisition of data from the sensing device or the uploading of collected data in various formats. Edge impulse allows data from different processing blocks to be available for training. This study will try in advance to apply different kinds of ML platforms such as the expert mode, custom processing blocks, etc.
- b) **The Arduino Integrated Development Environment (IDE), the open-source software tool application:** It is open-source software that provides an easy way of writing codes and uploading to the IoT devices and enables them to operate as the instructions say. The IDE could enable running into the different operating systems as the main support tools for creating such IoT projects including Windows OS, Linux, Androids, and MAC OS. The common language based on the IDE is the java programming language. The IDE helps to integrate the device and program it in the way the project goal is set.
- c) ***Fritzing the open-source IDE:*** In our study, we use a Fritzing for embedded engineers. It is an open-source development tool kit software. Fritzing is the VSM bridges the gap in the design life cycle between schematic capture and PCB layout. It helps to write and apply our project firmware to a supported microcontroller on the physical and schematic, then co-simulate the program. Fritzing allows you to interact with the design using on-screen indicators such as LED and LCD displays. It is not time-consuming to get understand on it and is easy to use. In our project, we were able to simulate both onboard simulation and schematic simulation.

Figure 3 shows the structure used to process data training in the ML platform.

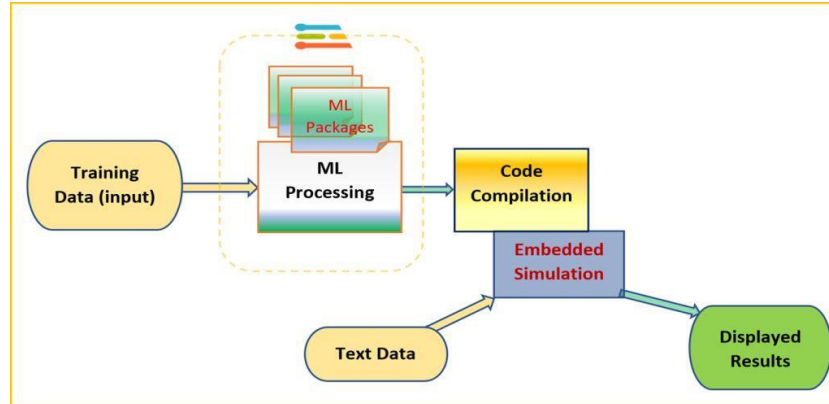

Figure 3: ML tool Stack, structure used to process data training in the ML

3.3 SYNTHETIC DATA METHOD OF DATA GENERATION APPROACH

Synthetic data explains the data generated using a purpose-built mathematical model or algorithm, with the aim of solving a (set of) data science tasks ^[34]. Important of discussing this scientific method is to protect privacy. Synthetic data is generated by a model often with the purpose of using it in place of real data. By controlling the data generation process, the end-user can adjust the amount of private information released by synthetic data and prevent its resemblance to real data. Also, it helps to adjust for biases in historical datasets and to produce plausible hypothetical scenarios.

We are considering using this approach because it will help in our prototype of the data-driven models and be used to verify and validate ML pipelines, providing some assurance of performance. It is the best approach that could fuel responsible innovation by creating digital sandbox environments used by start-ups and researchers in hackathon-style events. Synthetic data generation is a developing area of research, and systematic frameworks that would enable the development of this technology safely and responsibly are still missing.

The datasets of plant research mostly are massive, they are represented by images that are not so easy to process, and they need much time and well strong devices which cost a lot. So that the model of synthetic data is used to increase data in cases where there are low datasets. The steps of data synthesis start with a sample raw data that is uploaded into the synthetic data platform in a CSV format and submission acknowledgment given to the user. Then followed by the provisioning step in which free computing resources are allocated, and thereafter the encoding process in which data is transformed is done. After that, the neural network model is trained, and it uses to randomly draw a synthetic dataset. Finally, the accuracy and privacy contrast took place from the data analyzed which enable the quality assurance report to be generated.

3.4 DIGITAL SIGNAL PROCESSING

It is another method used to keep safe processed data. The observation of the collected data on the digital signal processing block enables us to have a clear view of the features that we want to feed into the Neural Network Technology (NNT). The flattened modules that looked at averages, standard deviation, minimum, maximum, skewness, and kurtosis are suitable for the kind of data being used. Upon review, feeding raw data of the available datasets without further processing showed a clear separation of features of raw data for both classes as shown in figure 4.

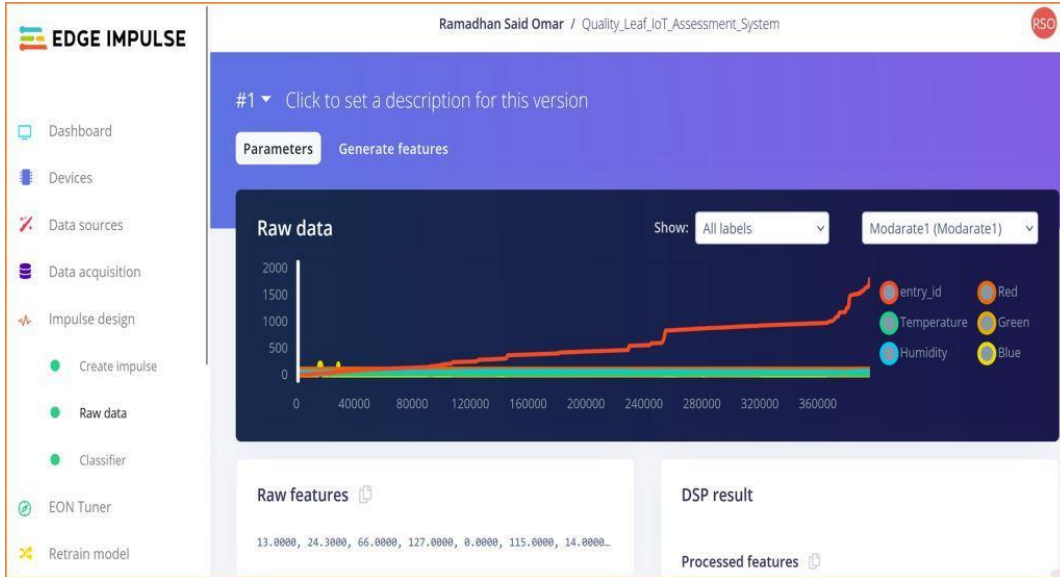

Figure 4: The initial starting point of the ML processing in Edge Impulse

3.5 DATASET AND ML DATA TRAINING

Performing training with the extracted features from the dataset with an embedded-aware ML framework. We applied Edge impulse to provide a native design of a Classification Neural Network (CNN). Raw features are extracted from the digital signal processing block of edge impulse before they are fed as input for the ML classifier algorithm. Due to the low volume of the acquired dataset, the ML process is based on a simple Neural Network (NN) that enables the default layered structure of Edge Impulse to fit the requirements. The NN consists of an input layer, two dense fully connected hidden layers, one having 20 neurons and the other containing 10 neurons, and the output layer for optimal performance of the derived model as shown in Figure 4. A predictive model is generated with varying accuracies that are hinged on the number of training cycles applied for the training process. To archive accuracies of up 80.0%, a number of up to 2000 training cycles is used. When inference is done to test data, the accuracy achieved was 97.6% which shows a best fit of validation accuracies.

3.6 SYSTEM DESIGN METHOD

The waterfall software development method was the selected method for the development of the embedded system given its evolutionary and iterative nature. The approach allowed us to improve the system and the ML model with each iteration. The technique gave us the simplicity to decide on areas of improvement within the iteration. It could make the development process rational and quick allowing the addressing of the most pressing issues immediately.

3.7 CONCLUSION

In this chapter we have been able to explain various methods, approaches and techniques that have been used to make this project successful. We have been able to see that the success of IoT projects requires a platform or the integration of various methods so that the work can bring good results. We have also been able to see that the system has been able to provide good accuracy of the result because of the enough trained data and various tests carried out during the implementation of this project. The waterfall methods system has enabled us to achieve this work well and achieve our goals.

CHAPTER IV: SYSTEM ANALYSIS AND DESIGN

4.1 INTRODUCTION

This chapter is the most important chapter in the development the structure of this project which defines the material and methods used in the study. The chapter begins by showing the high-level system architecture, detailed embedded System-level design showing the system block diagram, the Original Equipment Manufacturer (OEM) components, system Program Description Language (PDLs), and hardware and Software requirements. Moreover, the chapter demonstrates sample selection and design. Finally, the modelling and layout of the embedded system are given.

4.2 SYSTEM ARCHITECTURE

4.2.1 HIGH LEVEL SYSTEM ARCHITECTURE

High-level system architecture contained the high-level operational context of the solution. Using TCS3200 which is reading RGB color in the real object (Napier grass). The TCS3200 sensors then translate the detected leaf RGB color sample into a digital format for further processing and analysis. An ML model is then used to check the quality of leaves in the collected sample and detect the color inference done to determine if the leaf has nutrition or not. The three classifications observed results from the prototype determined are the *full Nutrition of the leave*, *Moderate nutrition*, and *Unhealthy leaf*. A status notification is then given via an LCD screen which is integrated into the Leaf Park Quality Assessing Kit (LPQAK) and LED color detects the type of color when the experiment is done. LED color sensors keep lighting in the same kind of RGB detected from the leaf. Additionally, a provision is included for sending feedback to the user's mobile phone via Wi-Fi technology. A DHT11 temperature and humidity sensor are used to maintain the humidity and temperature within the sensing unit being used to monitor the

temperature and humidity in real-time where the experiment is taking place. Figure 5 represent the high-level system development of the QLIAS.

Leaf Park Quality Assessing Kit (LPQAK)

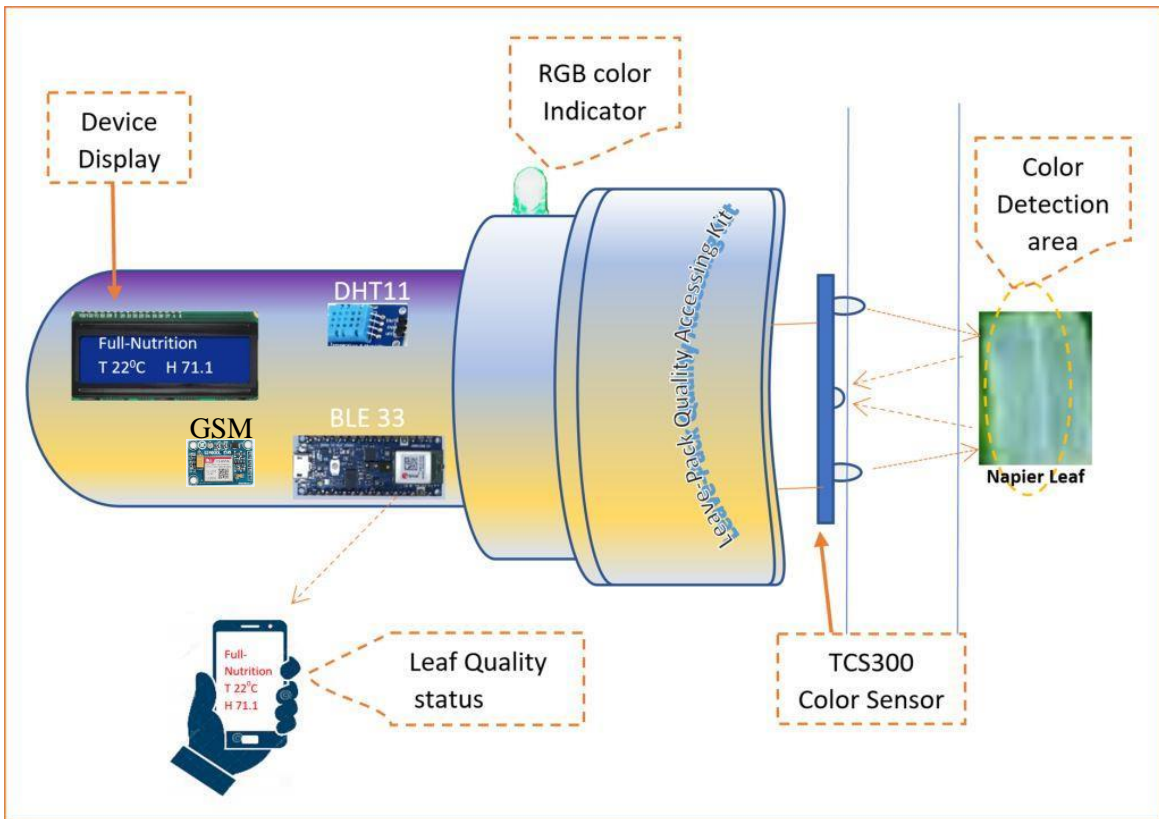

Figure 5: The high-level system development of the QLIAS

4.2.2 IOT SYSTEM ARCHITECTURE

QLIAS aimed to facilitate agricultural sustainability through livestock-keeping activities. The system is based on lightweight, low-cost IoT technology. The architecture of a standard of QLIAS is based on three layers; the perception or sensing layer, the communication or network layer, and the acting or business layer as described below. Why three-layered architecture, because is the

best-interacted architecture in IoT projects [35] more details are in Figure 6. Likewise, short-range cellular network technology is recommended in this system.

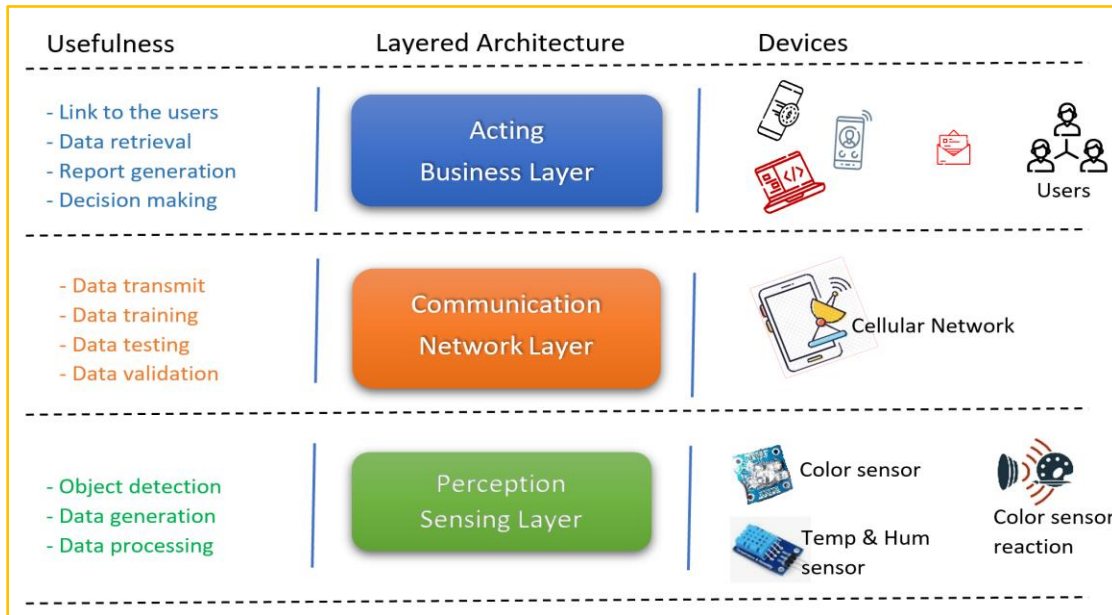

Figure 6: Network Architecture considered on the project development

4.2.3 THE THREE-LAYERED-NETWORK ARCHITECTURE DETAILED

The perception or sensing layer (SL) collects leaf information and other stimuli from the environment based on the deployed sensors in the surroundings or in the portable kit LPQAK (sensors such as RGB color sensor, GSM, temperature sensor, and related humidity sensors).

The communication or network layer (NL) handles data processing activities to obtain high-level relevant information on leaf characteristics, e.g., the detection of leaf color behaviour which influence the best fit quality of the leaf. NL will also help with data distribution to the other dependent part of the system, e.g., the end users who are targeted to receive the feedback.

The acting or business layer (BL) allows end-users to access services that are truly concerned with a particular QLIAS, in the aspects of the placement of the LPQAK kit by the users including animal caregivers, pastoralists, breeders, farmers, researchers, agricultural experts, therapists, and weather forecast teams. Relevant decisions are taken based on the result of the investigation done by the QLIAS. Meanwhile, users (animal caregivers) and concerned agencies will receive automated periodic updates when predefined levels of insects are detected. This system will go along wherewith ensuring government agencies, environmental regulatory bodies, and agricultural sectors get real-time data on insect detection so that corrective measures are put in place. Farmers will also get updates on insect outbreak areas to help them in taking precautions to avoid exposure and related risks.

4.3 EMBEDDED SYSTEM LEVEL DESIGN

4.3.1 SYSTEM BLOCK DIAGRAM

Our system block diagram is made in three main parts, the object area or sensing environment, the processing or sensor deployment environment, and the result or earlier display environment. In the sensing area, we have two main kinds of sensors, the temperature and humidity sensor which are represented by DHT11, and the RGB color sensor which is represented by TCS3200. DHT11 is integrated for recording the exchange of the weather parameter while the TCS3200 is for sensing the RGB color from the objects. Our project is going to minimize the current high operating cost of the current system, which is using a composition of many devices such as camera modules and other peripheral devices, which also cost too much and need much power to operate. LED and LCD screens are used to inform the user about the inference result in a user-friendly way. The

main board microcontroller is for processing the input element helped by the Wi-Fi module which is used to transmit data from one device to another device. The most important means of communication used in this design is short-range communication such as Bluetooth Low Energy (BLE) and Wi-Fi communication to potentially link the embedded device with the user's mobile phone. Finally, the system was in form of a portable single device which is powered by a saving energy power source with low power consumption which could enable the device to operate anywhere, anytime as shown in Figure 7.

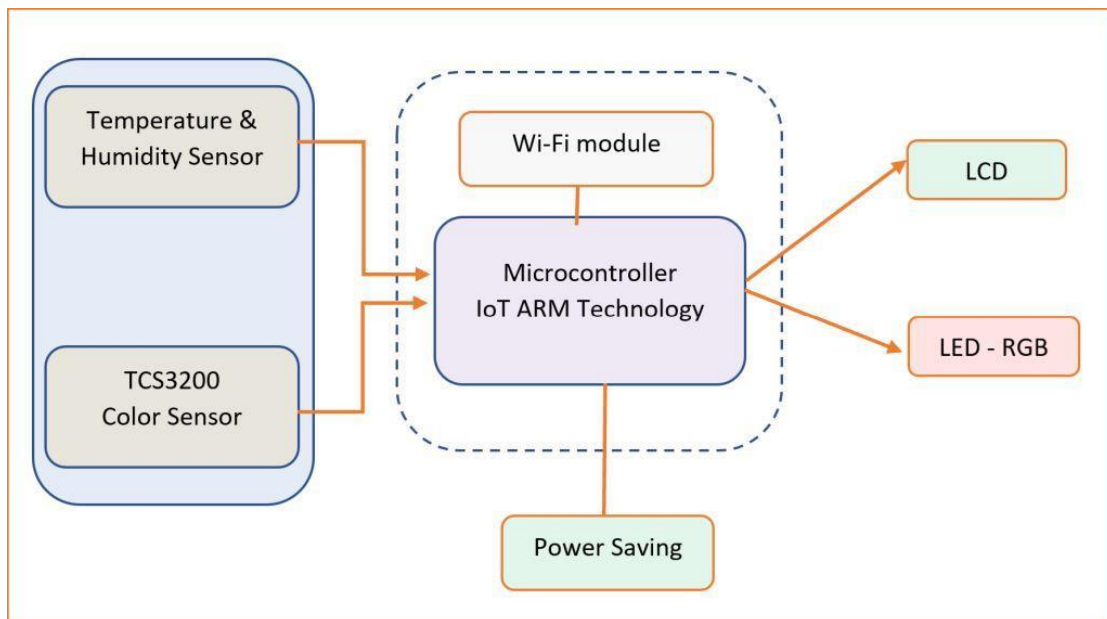

Figure 7: The system block diagram

4.4 SYSTEM REQUIREMENTS AND SPECIFICATIONS

4.4.1 HARDWARE REQUIREMENTS AND SPECIFICATIONS

Table 2 gives the summaries of main system hardware components for the prototype.

Table 2: Presents: Selected sensor types and IoT main components, technologies used, and the details of their uses

Sensor Name/ or Device type	Technologies Used	Use
Color sensor (TCS3200) [45]. ^[36]	Color light-to-frequency converter, Photodiode array, Output Enable, (OE) pin, Frequency scaling.	Enable high-resolution conversion of light intensives, Hi-impedance state, and Enable output range.
Temperature and humidity sensor (DHT-11) ^[37] .	Calibrated digital signal output, Including a resistive-type and NTC component, 8-bit performance.	Sensing and detecting the level of temperature, and amount of humidity.
Node MCU (ESP8266) ^[38] .	Low-cost open-source IoT platform, 32-MCU, Wi-Fi, and Bluetooth SoC.	An IoT system is a microcontroller processing unit.
LCD 16x2 ^[39] .	Electronic display, dimensions of 16x2 LCD display, contain 16 characters.	Used to produce visible images on IoT projects.
RGB LED sensor ^[40] .	Low thermal Resistance, High flux output, and high luminance, No UV rays.	Used to display multi-chip Red, Green, and Blue (RGB) LED light.

4.4.2 HARDWARE CAPACITY SPECIFICATIONS

a) *DHT11 temperature and humidity sensor*

The DHT11 is a basic, low-cost digital temperature and humidity sensor. It is used a capacitive humidity sensor and a thermistor to measure the surrounding air and generate a digital signal output on the data pin (no analogue input pin needed). It is fairly simple to use but requires careful timing to detect data. The only limitation of these sensors if you can only get new data from them once every two seconds. Its small size, low power consumption, and up-to20-meter signal transmission make it the best choice for temperature and humidity applications.

b) TCS3200, The RGB color detection sensor

A color sensor in figure 8 The TCS3200 is a programmable shading light-to-recurrence converter/sensor. The sensor is a solitary solid CMOS incorporated circuit that consolidates a configurable silicon photodiode and an accurate-to-recurrence converter. The standard leaf quality was obtained by measuring the RGB value of the standard color from the Napier leaf using the TCS3200 sensor. Therefore, RGB values were converted into a color index. Usually, the conversion of RGB values is carried out using three formats of the following equations.

$$\text{Red color index} \quad (I_R) = \frac{R}{R + G + B} \quad (1)$$

$$\text{Green color index} \quad (I_G) = \frac{G}{R + G + B} \quad (2)$$

$$\text{Blue color index} \quad (I_B) = \frac{B}{R + G + B} \quad (3)$$

Significantly, the color sensor has the ability to determine different colors from the objects. They will utilize a means of emitting light and then look at the reflected light to determine an object's color. This will give the machine the IoT actual color of that object. Majority of researchers have shown that 90% of edges in color images can be found in their corresponding grayscale images, and the remaining 10% of edges may not be detected in intensity images due to a change in color, which may cause the failure of vital computer vision tasks ^[41], ^[42]. Hence the following formular is based on target variable data which was the color and then founds the rate of leaf quality by using the formula proposed by ^[42].

$$\text{Pixel}(i,j) = 2 * \text{red}(i,j) + 3 * \text{green}(i,j) + 4 * \text{blue}(i,j) + 2 * \text{Hue} \quad (4)$$

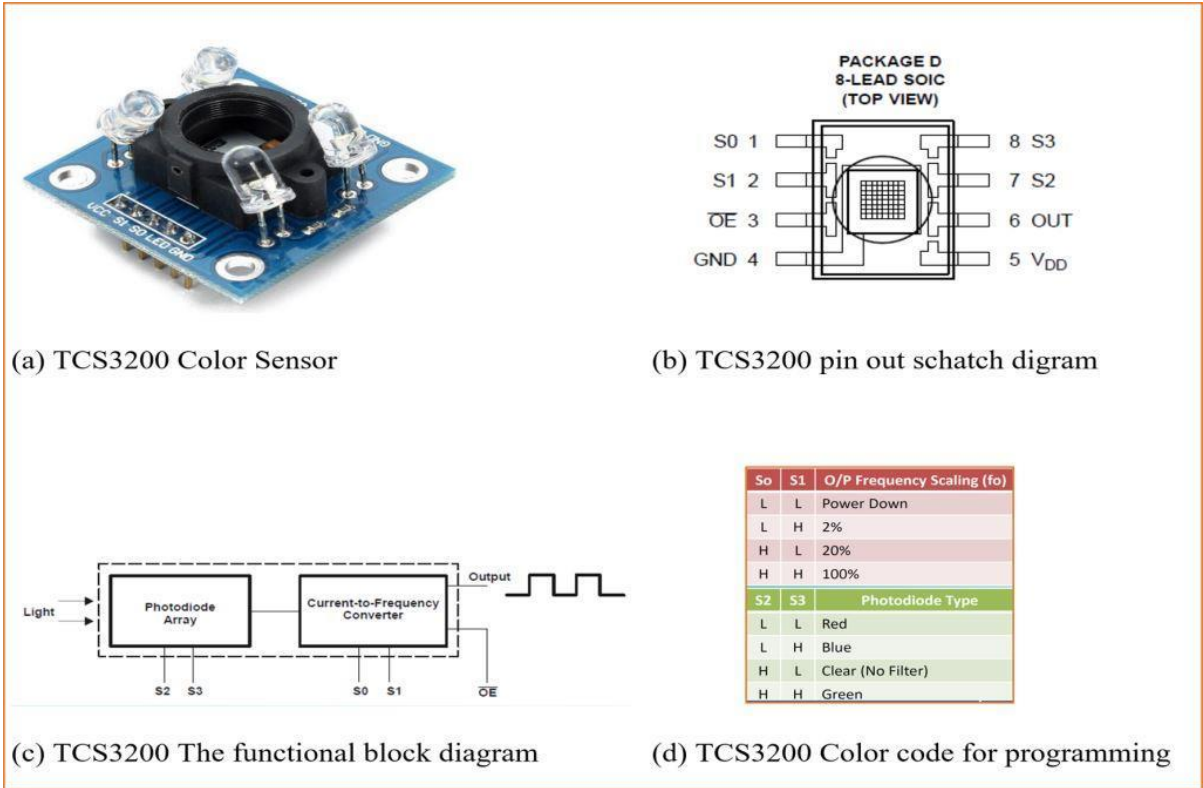

Figure 8: The TCS3200 color sensor with a specific description represented by a, b, c, and d.

c) Arduino Nano BLE sense IoT microcontroller

The Arduino Nano 33 BLE sense is built upon the nRF35840 microcontroller from Nordic Semiconductors, a 32-bit ARM® Cortex™M4 CPU. It runs on ARM Mbed OS making it appropriate for solutions that involve embedded machine learning. The devices are integrated with Bluetooth low-energy modules [43]. The device allows the creation of machine learning models using TensorFlow™ Lite and uploading them to the board using the Arduino IDE. Figure 9 demonstrates the BLE device and other necessary information.

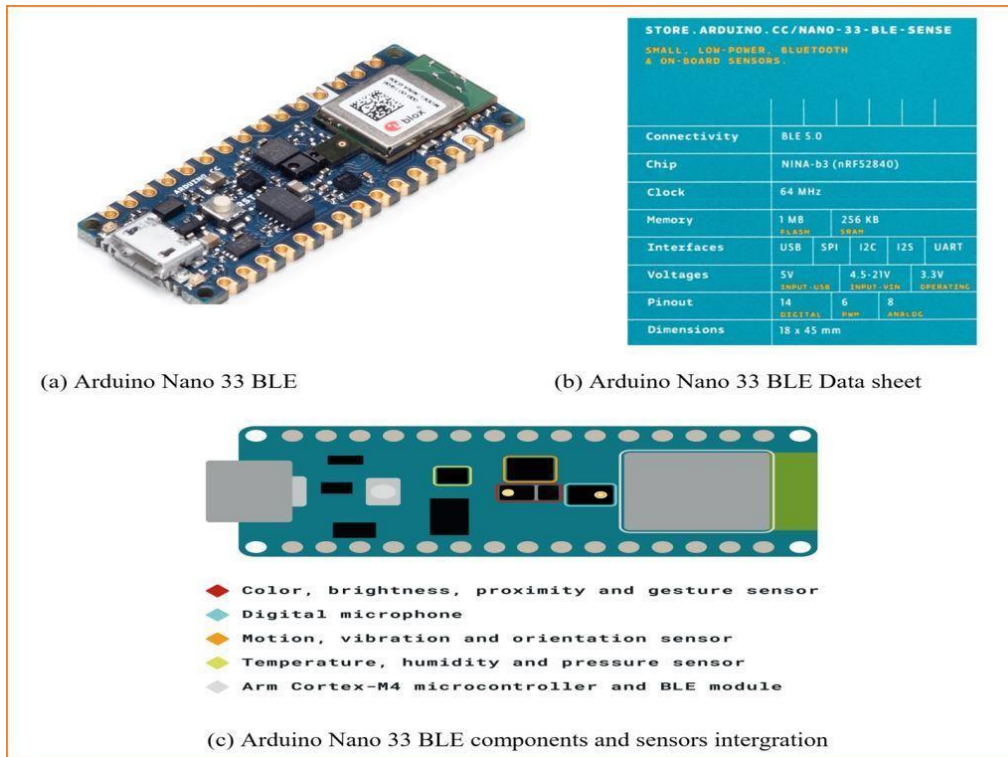

Figure 9: The Arduino Nano BLE 33 with a specific descriptions a, b, and c.

d) LCD display module

An LCD screen is a module for electronic displays, Liquid crystal is used to produce visible images. The LCD comes in various shapes and sizes for example 16x2, 20x4, etc. In this study, we use 16x2 LCD type as described in [44].

e) Common-cathode RGB LED a color display actuator

The Red-Green-Blue (RGB) is three LEDs in one. By controlling the intensities of each of the three component colors individually, it creates all of the colors that the project needs. The common name of this RGB LED is called common-cathode RGB LED. It is used to display and give alerts or signals of the color of the project color output of the object. In our study, the RGB cathode was used to link the tested leaf and produce the nature of the color of the leave.

4.5 THE SYSTEM DESIGN FLOWCHART, PROGRAM DESCRIPTION LANGUAGE (PDL)

This part highlights the structural common description of main function based in this study. Program Description Language (PDL) is a free format English like text is describe the flow of control and data in the system of this study which is based mainly in four main functions. Figure 11 presents a pseudocode PDL system main function whale figure 10 show the flowchart.

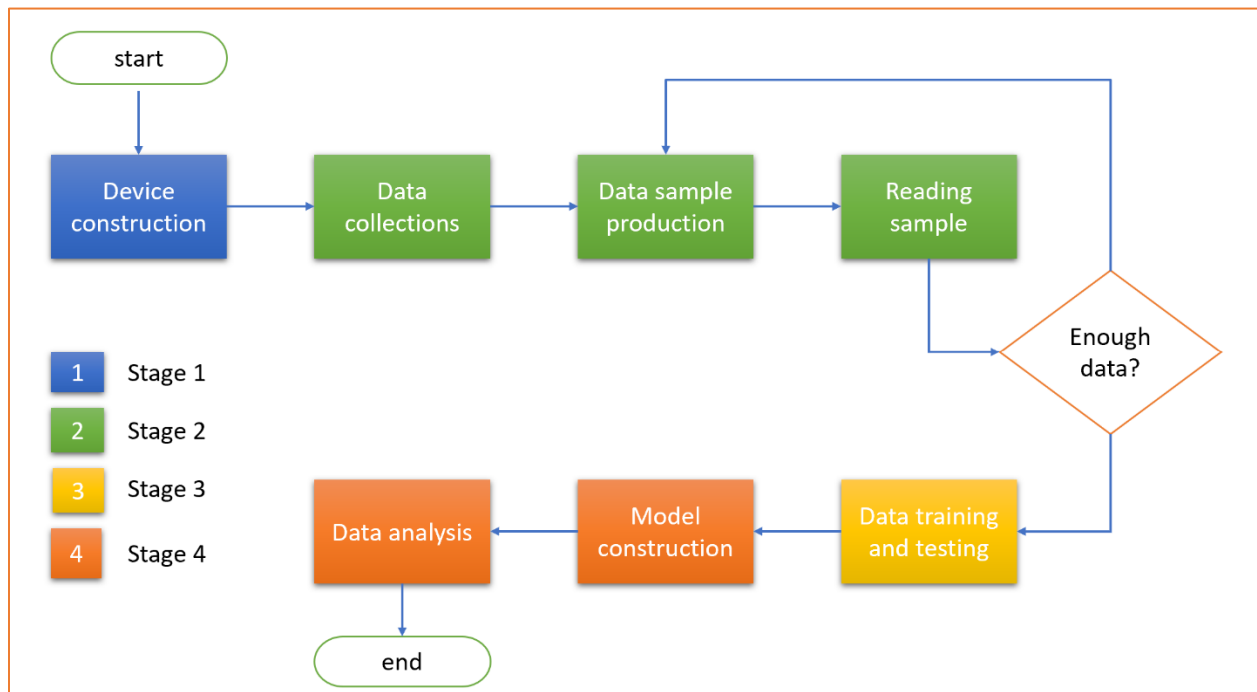

Figure 10: Flowchart of the system

The program is started when the device is turned ON with the initialization of a variable, then displays a welcome message and automatically calls Start RGB program which displays the current time, temperature and humidity values. Shortly after the button start sensor is pressed the sensor starts to scan RGB color from the leaf for collecting leaf sample while the scanning program triggers the assessment of the leaf quality color detected and classifier from the sample followed by a give the notification in both RGB LED color actuator and display devices

```

BEGIN
  DO FOREVER
    CALL Welcome
    IF Button pressed THEN
      CALL START_RGB
    ELSE
      Continue Welcome
    ENDDO
END

```

(a) Main Program

```

BEGIN/Welcome
  Display "Welcome message"
  Display "Operation Task"
  Wait for 5 second
  CALL START_RGB
END/Welcome

```

(b) Sub Pro. Welcome

```

BEGIN/ START_RGB
  CALL CurrentTime
  CALL DisplayTemperature
  Wait for 10 sec
END/ START_RGB

```

(c) Sub Pro. Start RGB Color ON

```

BEGIN/StartSensor
  DO WHILE Button pressed
    Display Instruction
    Sense Color from Leaf
    Display Sampling result
  ENDDO
  Record Parameter on Scanning leaf
END/StartSensor

```

(d) Sub Pro. Sensor operation

```

BEGIN/ScanningLeaf
  Check sample of leaf RGB
  IF RGB detected THEN
    Display type of color
    Same color Display on RGB LED
  ELSE
    Start Process
    Display color result
    Send Leaf result notification
  ENDIF
END/ ScanningLeaf

```

(e) Sub Pro. RGB Color Sensor Scanning the Leaf

Figure 11: PDL System functionality main and sub program represented in a, b, c, d and e

4.6 EDGE IMPULSE ML FUNCTIONALITY PERFORMANCE

This section is based on performing ML training with the extracted features from the given datasets. Edge Impulse provides a native design of the classification Neural Network (NN). Raw features are extracted from the digital signal processing block of edge Impulse before they are fed as input for the ML classifier algorithm. Due to the volume of the acquired dataset, we use a simple NN because of the low number of datasets.

4.7 HW/SW EMBEDDED SIMULATION

In the previous section, we simulate the ML inference in the visual simulator before testing it on a real development board. In the simulation context, the performance of edge impulse inferencing was validated by reading test data from a file and comparing the inference results with the ideal result from leaf sampling and calculated by the cloud platform used in the training. However, the study uses fritzing online simulator tool as our embedded modelling and simulator tools as shown in figure 12 which presents HW/SW embedded and schematic simulation on figure 13.

(a) HW/SW Embedded Simulation

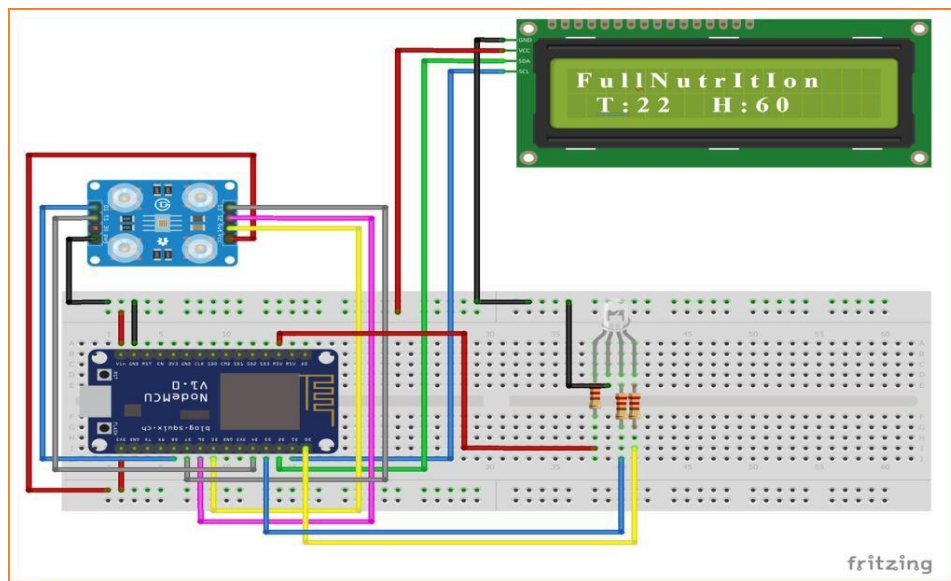

Figure 12: The Hardware and Software Embedded Simulation

4.8 HARDWARE SET-UP

4.8.1 MIND MAP OF THE QLIAS PROTOTYPE

Mind map of the hardware setup of the QLIAS prototype. The system is based on collection of sensors DH11 which is external to the BLE board, color sensor TCS32000 and the idea of the communication module both node MCU which was used for data collection and GSM8001 which is used on system end user sample as shown on the figure 14.

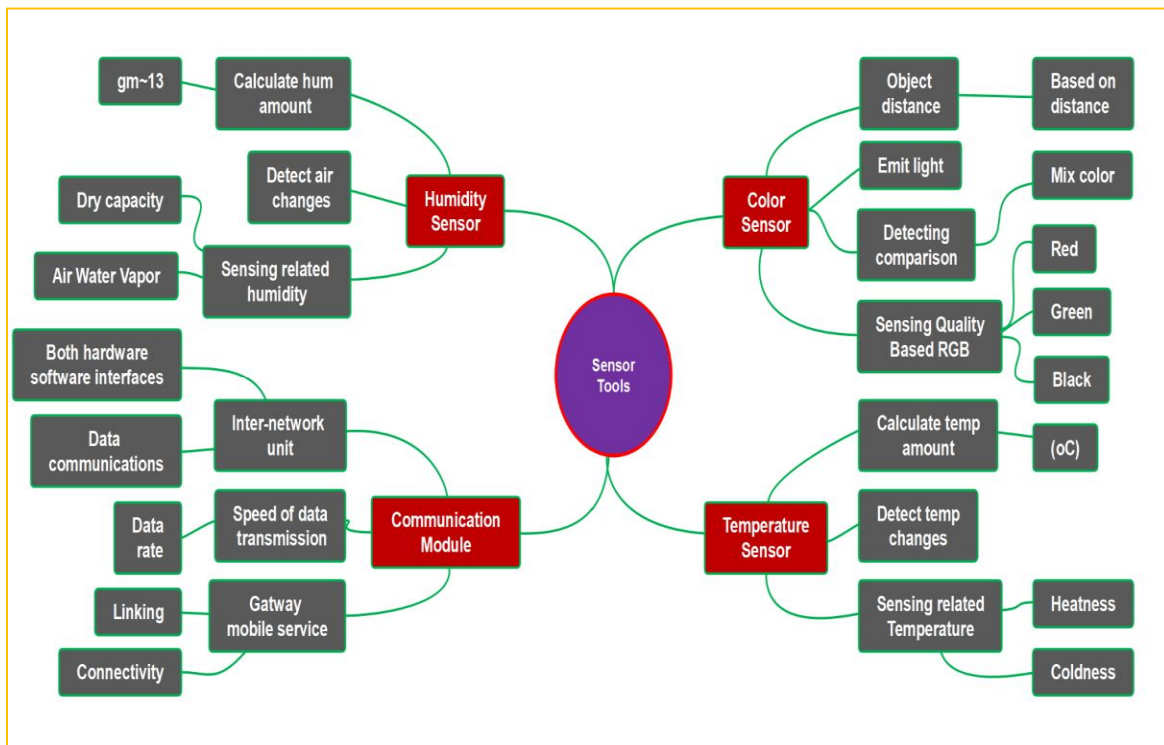

Figure 14: The mind map of the Hardware Sensor tools

4.8.2 HARDWARE SET-UP

The hardware set-up is composed of a breadboard, an Arduino Nano BLE Sense 33 (or Node MCU32, or NodeMCU8266), LCD and RGB LED color actuator which are integrated through

jumper wires. The aim of the setup is to show the result as acquired from the cloud platform. The figure 15 simulates the embedded devices setup and in figure 16 is the communication media.



Figure 15: Embedded devices setup

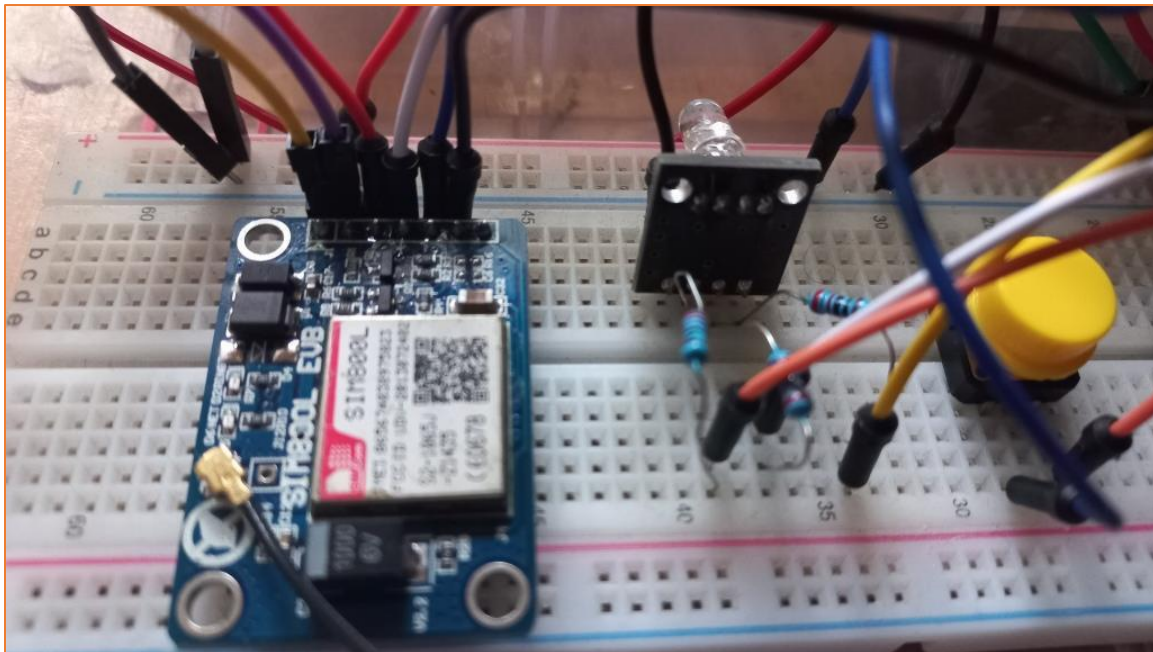

Figure 16: The communication module setup

TCS3200 Color sensor

The sensor was based on the classification of reading color according to the pairs represented by s0, s1, s2, and s3. Reading color performance depends on the value of low and high. L represents low value while H represents high value. The code RGB color was calculated to the combination of the group formed by s2 and s3 to produce photodiode RGB color type as following table:

RGB LED cathode

Has 4 legs for Red, Green, Blue, and Ground connectors. Connected the longer pin of RGB led is the cathode was connected to the GND of the Arduino board, and the other 3 pins were connected to the digital pins 13, 12, and 11 integrated with 220 ohms resisted. The main purpose of the RGB LED cathode used in this project is to indicate the active color scanned to the Napier leaf.

16x02 LCD

The LCDs have a parallel interface and use an i2C module, made with 4-pin connectors including a read and write pin, Enable pin, Data pin, and power of 5v pin.

- R/W: A Read/Write pin that selects writing mode or reading mode.
- Enable: An Enable pin for enabling writing to the registers
- Data Pin: The state of the pins is either high or low and are the bits that are written or read from the registers.
- Others include power supply pins (+5V) used to power the LCD, and a display contrast.

4.9 CONCLUSION

This chapter highlights how the research was handled. The research was divided into two major phases that consist of the integration of the development of the main project components and the simulations. Relevance ML tools were pointed out with description and relevance to each segment of the research producer. The system set-up also was presented in this chapter, whereby the hardware components are able to give descriptions and an overall circuitry of the final system is portrayed.

CHAPTER V: SYSTEM RESULT AND ANALYSIS

5.1 INTRODUCTION

In this chapter, the key concept result description is discussed. This section presents the validation results of data creation and ML inference accuracy using the Napier quality leaf-created dataset from our project prototype.

5.1.1 LPQAK FOR NAPIER LEAF DATA COLLECTION

The data were collected in October 2022 during the development of this work, around 3822 raw data were stored in the cloud of the ThingSpeak platform. Figures 17 shows the prototype developed by us using Node MCU is capable of generating data and sending it to the cloud of ThingsSpeak.

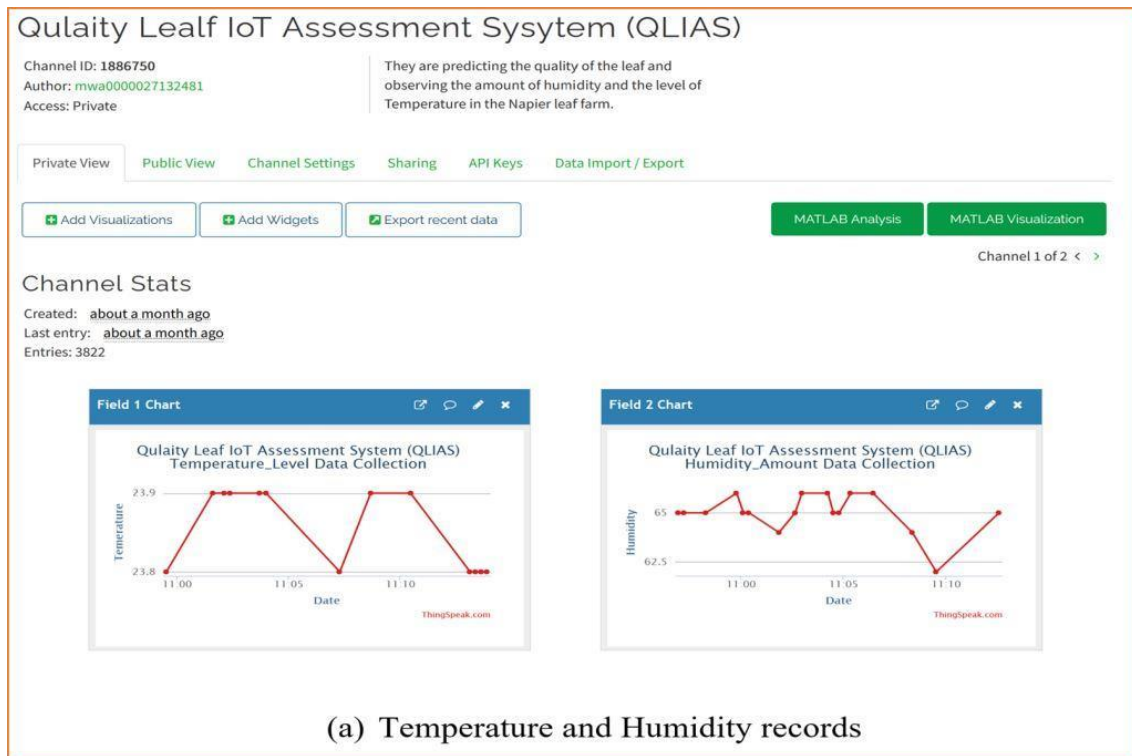

Figure 17: ThingSpeak Cloud based store Napier leave data

5.1.2 DATA SEQUENCE AND CORRELATED

This study also was based on two main objectives. The first is to support the availability of Napier leaf data because there is not enough open data available in the open datasets. The second goal is to enable this study to provide the best statistics of the general research we have done. So, we have been able to achieve the first step of making a prototype capable of sending data to Cloud and generating a CSV file that could help to various researchers in their future research. Figure 18 shows the statistics of the original collected data in the cloud saver. MATLAB Visualization tools were used to visualise the original data. visualizing correlated data using the SCATTER function, single sequence data plot.

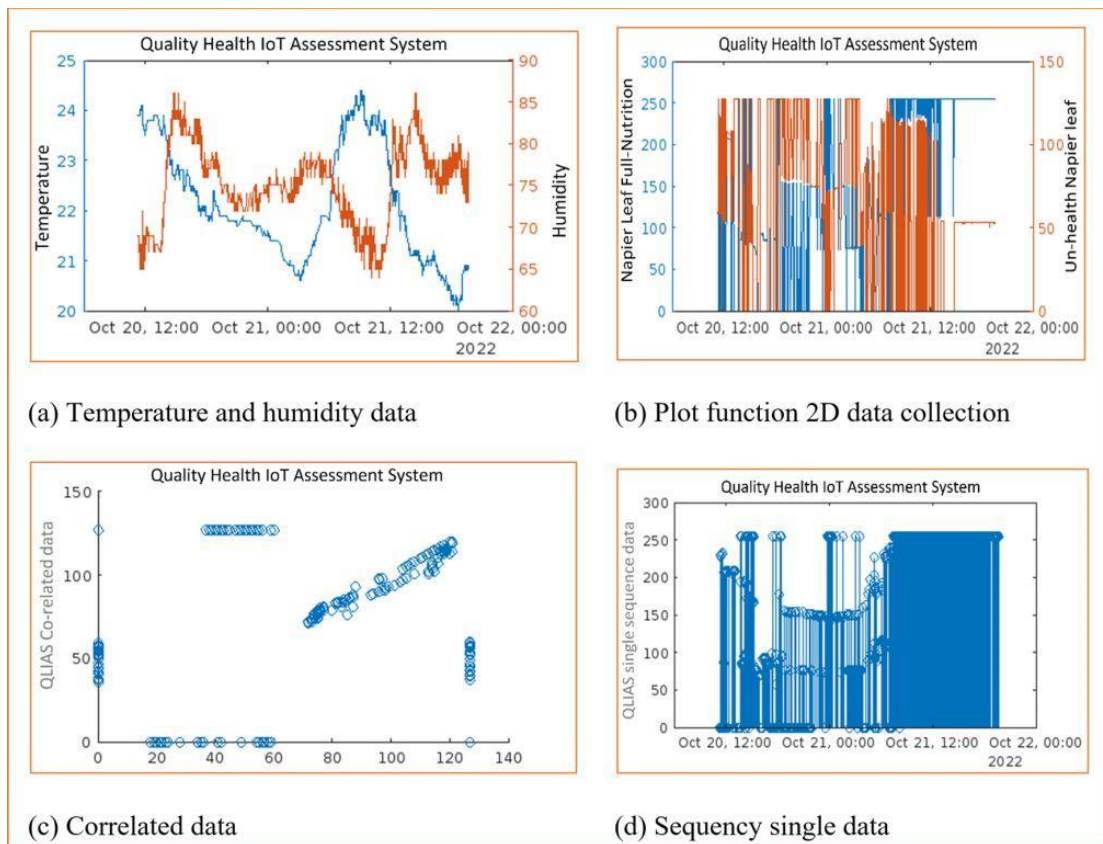

Figure 18: MATLAB Visualization of stored data in cloud

The ThingSpeak MATLAB Visualization which supports 2D has been used to provide an advanced interpretation of the data in the online cloud database. Graph (a) describes the ratio of records of changes in temperature and humidity during the collection of these data. This shows that the temperature and humidity sensor is in a good performance in our system. Graph (b) involves two types of data and brings a balance of how data can be recorded over time through this system. Since this platform supports only 2D graphs, this graph has taken the data of full nutrition and unhealthy leaf and has been able to help show the correct balance of data entry. Graph (c) shows the correlation of the data collection in the cloud, and graph (d) shows the reality of the sequence of single data that can flow in the ThingSpeak online cloud. This analysis shows that our cloud data collection system has been successful and the possibility of data collection will be sustainable. This can help facilitate the effectiveness of other studies related to Napier grass.

5.2 ML MODEL

5.2.1 NAPIER LEAF DATASET

Our project could be able to create data and store it on the online cloud platform in the ThingSpeak server. Dataset was collected in October 2022 in the Nyagatare District, Northern Province of Rwanda where livestock keeping is practiced in 70% percent of the whole animal production of the country. The dataset collected was in a CSV file, which includes three different dependent files, such as the file of Napier full nutrition leaf data, Napier moderate nutrition leaf data, and Napier unhealthy leaf data. On the other hand, the project has been able to collect temperature and humidity data that can show changes in the weather during the data collection exercise, temperature and humidity data have been collected using the DHT11 sensor. The TCS3200 has

been used to record the color of Napier grass leaves. Figures 19, 20 and 21 show the datasheet used in finding accuracy and loss for this project.

timestamp	entry_id	Temperat	Humidity	Red	Green	Blue
1000	25	24.8	62	0	127	112
2000	26	24.8	61	0	127	113
3000	27	24.7	62	0	127	113
4000	28	24.7	62	0	127	113
5000	29	24.6	62	0	127	113
6000	30	24.6	63	0	127	104
7000	47	24.3	73	58	127	0
8000	49	24.1	68	58	127	0
9000	50	24.1	68	58	127	0

Figure 19: Napier Leaf Full Nutrition (Health leave)

timestamp	entry_id	Temperature	Humidity	Red	Green	Blue
1000	13	24.3	66	127	0	115
2000	14	24.3	66	127	0	108
3000	15	24.3	66	127	0	110
4000	16	24.3	66	127	0	115
5000	17	24.3	66	127	0	115
6000	18	24.2	66	127	0	113
7000	19	24.3	68	127	0	85
8000	20	24.9	64	127	53	0

Figure 20: Napier Leaf Moderate Nutrition

timestamp	entry_id	Temperature	Humidity	Red	Green	Blue
1000	31	24.6	62	50	0	255
2000	32	24.6	64	107	108	215
3000	36	24.5	63	55	0	255
4000	38	24.4	64	122	117	234
5000	39	24.3	65	122	117	234
6000	48	24.2	68	116	116	225

Figure 21: Unhealth Napier Leaf

5.3 MACHINE LEARNING DATA TRAINING

5.3.1 ML POSSIBLE TECHNIQUES

The following are the appropriate ML techniques that could be applied to this project.

a) Artificial Neural Network (ANN)

Artificial Neural Networks (ANN) is an AI research domain using ML ^[45]. The main purpose behind the research in this domain is to insight into and construct a machine learning-based system that can study and analyze the bioelectrical activities and biological model of the plant's characteristics. ANN supervised learning model is the best fit solution that could apply in such kind of this project. ANN works as an intelligent recognition network machine ^[46]. The ANN's mathematical model and learning process are presented in ^[47] and ^[48].

b) Support Vector Machine (SVM)

Support Vector Machine (SVM) in ^[49] are the models based on supervised learning that is associated with learning algorithms that provide a useful pathway to analyze data based on classification and regression analysis. SVM is useful in three main parts of data analysis ^[50], ^[51], (1) The ability to compare to other model techniques SVM uses the less minimum number of features. (2) SVM model robustness is more efficient compared with the error of models, and (3) SVM computation time is less and more efficient than the others.

c) *k*-Nearest Neighbor (KNN)

k-Nearest Neighbor (KNN) is the algorithm for classifying objects based on the closest training examples in the feature space in pattern recognition. KNN methods can create both classification

and regression models as well. KNN is a type of instance-based learning or lazy learning where the function is only approximated locally and all computation is deferred until classification [52], [53], [54], [55]. under the simple rule guides. KNN has the following usefulness: simplicity, effectiveness, intuitiveness, and competitive classification performance in many domains.

5.3.2 ML DATA PERFORMANCE BEFORE TRAINING

As we explain in the previous section, the edge impulse online platform is used to conduct the ML data training process. The platform allows the user to upload data, we used to upload three pieces of data into CSV file format. Data accuracy presented on the figure 22 were captured before to train datasets.

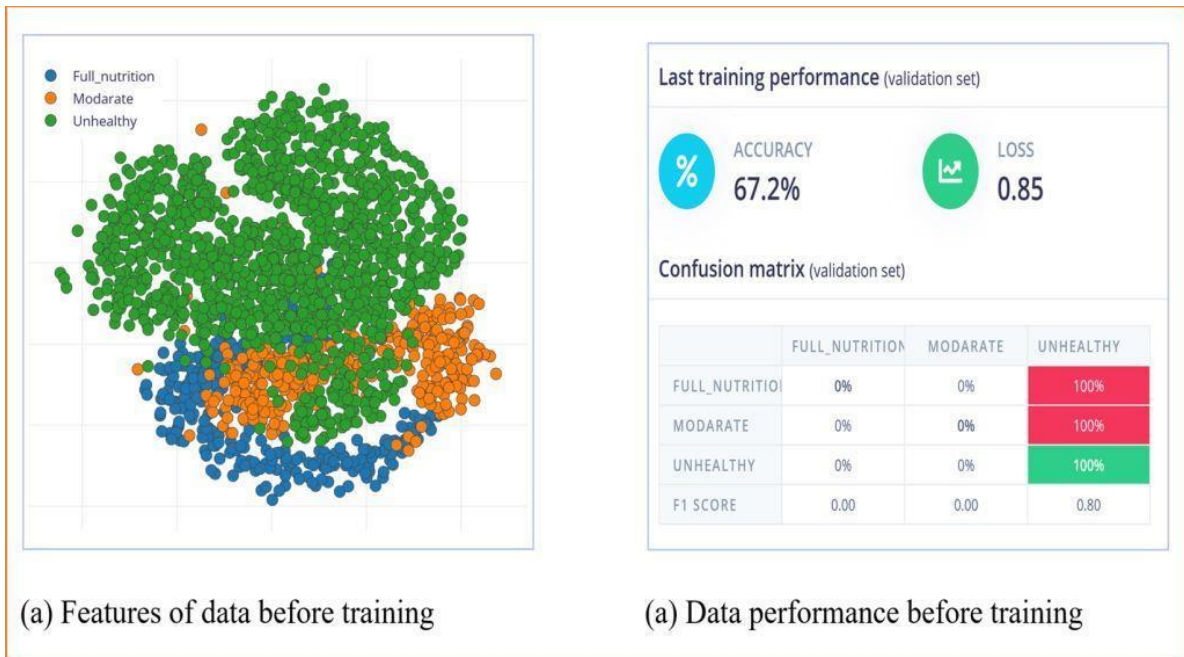

Figure 22: The nature of the data before ML training process started

5.4 MACHINE LEARNING DATA TRAINING

Edge impulse metrics of how the model had performed on the actual hardware are as follows: 1.7K RAM usage, a latency of 1ms, and 16.3K ROM usage for an accuracy of 0.97% for the targeted

model optimizer EON compiler using the NN ML algorithm. Figure 23 shows comparisons. Raw features are extracted from the digital signal processing block of edge impulse before they are fed as input for the ML classifier algorithm. The neural network consists of an input layer, two dense fully connected hidden layers, one having 20 neurons and another 10 neurons, and an output layer for optimal performance of the derived model created. A predictive model is generated with varying accuracies that are hinged on the number of training cycles applied for the training process.

To achieve accuracies of the best performance, a number of up to 2000 training cycles were used. In the implementation of ML algorithms, NN is explored for classification methods. NN has several unique benefits in solving samples, and nonlinear and high-dimensional pattern recognition which can be extended to function in the simulation of other machine learning problems. After training the NN model using Edge impulse, the estimated real-time resources on an ARM-cortex microcontroller are 1.7K of RAM memory for processed data, a latency of 1ms, and 16.3K ROM memory to save the ML model. The model evaluation in cloud settings achieves an accuracy of 97.6% for the targeted model optimizer EON compiler using the NN ML algorithm.

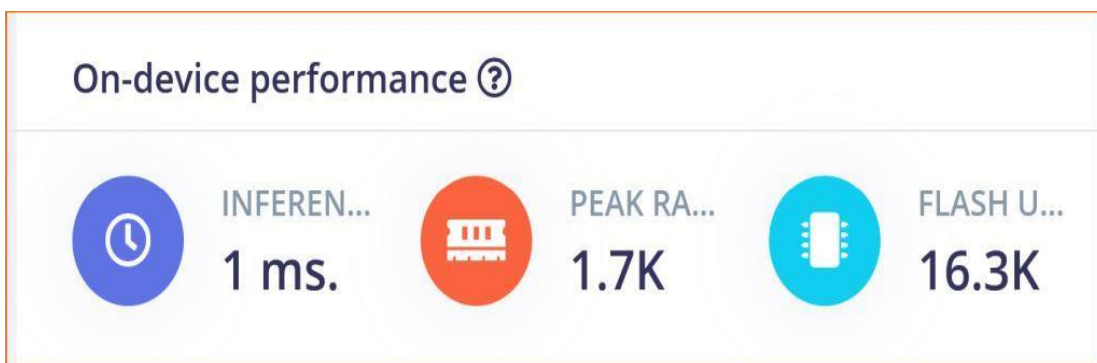

Figure 23: Edge Impulse actual Hardware performance during ML processing

5.4.1 SYNTHETIC DATA GENERATION RESULTS

The features from the data were extracted before the model training this was done to reduce the amount of processing power that will be needed to generate the features in an embedded system.

Fig. 24 shows a sample of the generated features.

The number of training epochs for both projects was set at 30 with a 0.0005 learning rate and 0.20 minimum confidence rating. The neural network architectures were each composed of four layers; an input layer with 12 features, 2 dense layers with 10 and 20 neurons respectively, and an output layer with 3 features.

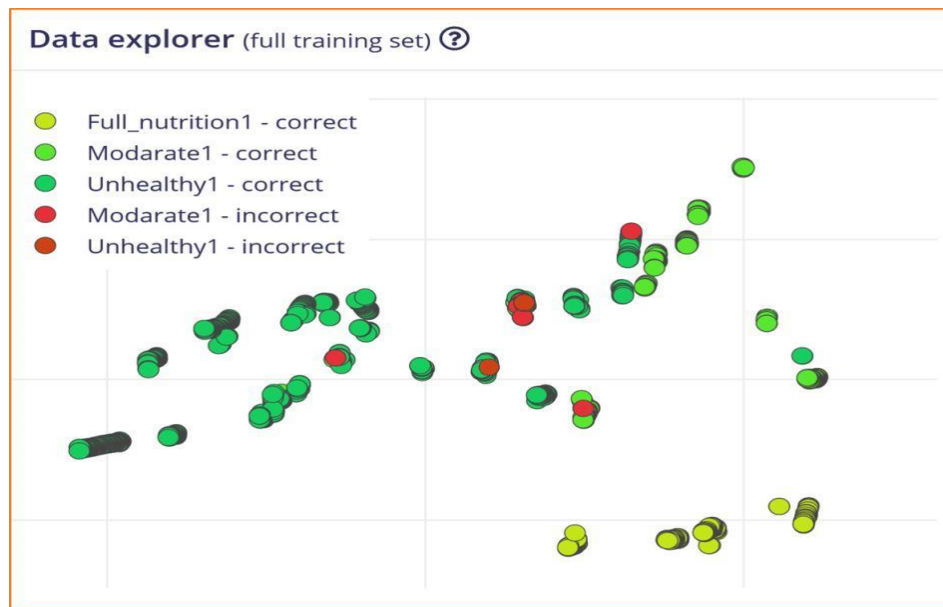

Figure 24: Generated synthetic data after training

5.5 RESULT PERFORMANCE OF THE PROJECT INFERENCE

A validation accuracy of 97.6% was achieved with a loss of 0.12% for the model based on a synthetically enhanced data set. Figure 25 shows the confusion matrix for the validation set.

Furthermore, his figure shows that the results of our training data have met the requirements of the

model we created. Based on the data collected and trained, has brought good results for the interpretation of the reality and the fitness of the existing data. With this logic, the interpretation of this model is that it has been able to meet and can be used for testing various samples in the relevant field.

On the other hand, the results of the accuracy of full nutrition have reached 100%, which indicates that they are at the same level, while the results of moderate nutrition, which have reached 89% and are similar to 11%, remain on the unhealthy leaf side, it is a mathematically correct equation for either mode moderate nutrition can depend towards and give support to the unhealthy group.

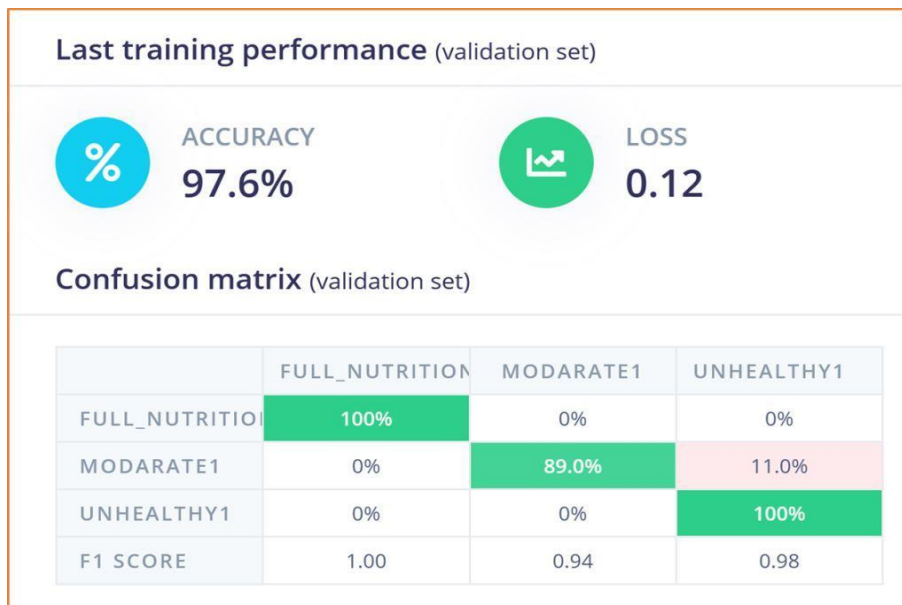

Figure 25: Synthetic data model confusion matrix Accuracy performance

5.6 RESULT DISCUSSION OF ACCURACY PERFORMANCE

We observed some differences when pre-testing results are compared to those achieved during live classification. Model optimizations ensure the model takes up the least memory and is efficient. During performance data training aims to have optimal on-device performance but may increase accuracy if we could test enough data.

In this case, embedded device accuracies reflect the higher accuracies achieved from the Edge impulse platform as shown in the figures above. An actual hardware device would perform and give us an insight into the feasibility of deploying the actual hardware device. Upon conclusion of training, accuracies of up to 97.6% were achieved using the Neural network Kera's. And the figure 26 shows the difference between Synthetic differences in data testing performance.

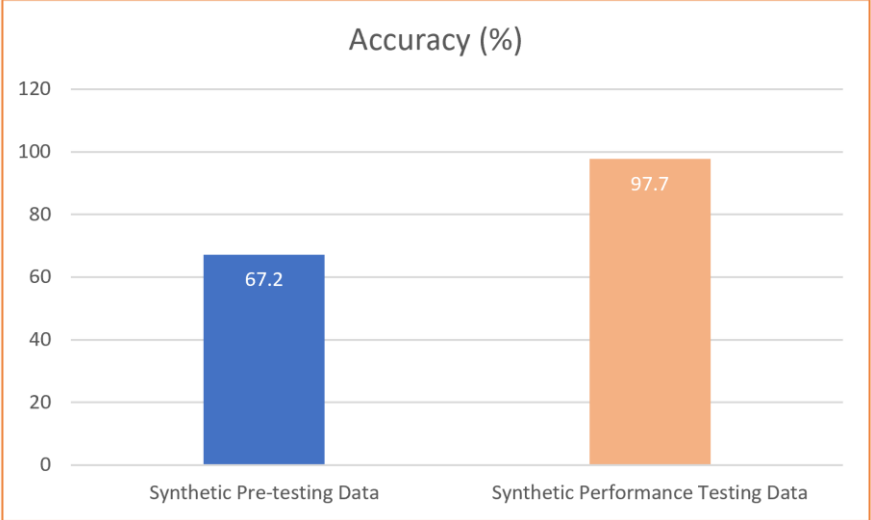

Figure 26: Synthetic differences on data testing performance

5.7 DIFFERENCES IN DATA PERFORMANCE INFERENCES IN TESTING MODEL ON SIMULATION TOOLS AND THE ACTUAL DEVICE BOARD OPERATION

We use edge impulse tools to estimate and compare the tested data output and further the actual data deployed on the device. The results show that there is a great similarity in the results of this study. Meanwhile, the configuration of the hardware device does not have a big bad impact because it is the same level of use, for example, the capacity of RAM in the data processing is used very little.

The accuracy obtained has shown that the possibility of Napier grass data using a color sensor is well suited to be processed by ML so that they can provide accurate interpretation. In this research, the type of moderate leave has been taken as a sample to measure and compare the accuracy of these data. Figure number 27 shows the results of the data tested using the edge impulse online tools.

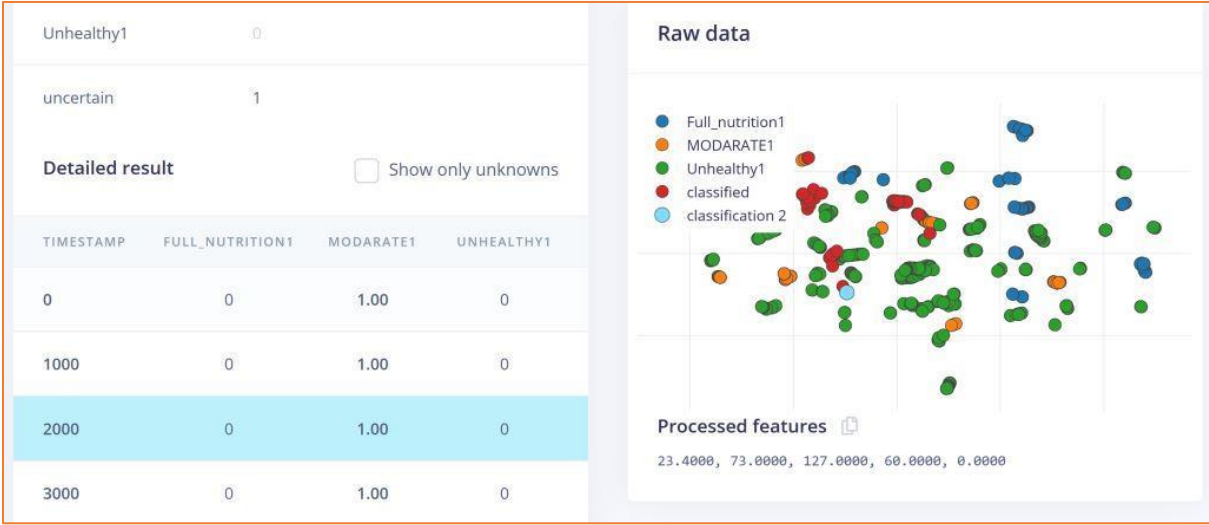

Figure 27: Testing data sample results

Figure 28 demonstrates the result of accuracy measured on the actual device. Edge impulse usually has the ability to create a library that enables you to train data, this library can be used to support your deployed programming, especially for devices that support ML such as the nano 33 BLE.

With the use of a small code of edge impulse, it enables your library to bring the output of your tested samples the same or not quite big differences. We have seen that the result still remains in the 99% percent.

```
8 + |in|less required by applicable law or agreed to in writing. software
9
Output Serial Monitor x
Message [Enter to send message to 'Arduino Nano 33 BLE' on 'COM7']
.....
Edge Impulse standalone inferencing (Arduino)
run_classifier returned: 0
Predictions (DSP: 0 ms., Classification: 0 ms., Anomaly: 0 ms.):
[0.00000, 0.99609, 0.00000]
  Full_nutritional: 0.00000
  MODARATE1: 0.99609
  Unhealthy: 0.00000
Edge Impulse standalone inferencing (Arduino)
run_classifier returned: 0
Predictions (DSP: 0 ms., Classification: 0 ms., Anomaly: 0 ms.):
[0.00000, 0.99609, 0.00000]
  Full_nutritional: 0.00000
  MODARATE1: 0.99609
  Unhealthy: 0.00000
```

Figure 28: Static Buffer from library created by the edge impulse display 99% of the tested data in the actual device

5.8 CONCLUSION

This chapter discussed the inference of how the research was practiced. The research inferences were discussed into two major situations, including how the data performance is ensured to be stored in the online cloud database and how the system becomes reliable in case of the training and testing process. Furthermore, the chapter highlighted the best fit of data processing of the actual performance of data processing through the discussion of the edge impulse a platform used to analyze data. Last but not least, the chapter discusses the performance of the accuracy of trained data and performs differences between the pre-testing synthetic data and synthetic data performance.

CHAPTER VI: CONCLUSION AND RECOMMENDATIONS

6.1 CONCLUSION

Napier grass is one of the main food of livestock animals which is the backbone of the income of Rwanda's economy. The use of IoT and ML provides opportunities that can assess the quality of Napier leave before feeding to the animal though the collecting data using cost less device. However, the development of better ML models for the prediction of Napier leaves quality has been hindered by a lack of enough datasets and privacy issues limiting access to data, limited research is done in this field.

This research thesis presents an embedded experimentation-driven methodology for designing and developing a portable Kit based on assessing Napier leave quality. From experimentation, we successfully validated the ML inference accuracy to predict Napier leave quality. We analyzed the impact of varying different embedded real-time resources such as the color scanning sensor and temperature and humidity sensor. This study also explored the use of synthetic data as a solution to the lack of datasets after developing a possible tool to sense Napier leave parameter. An evaluation was done with created data sets on QLIAS system. The model had trained one based on a created dataset and the other on synthetic data, with both models performing at almost the same accuracies of 97.6% respectively. On the other hand, the system has been able to bring the balance of training and testing data sample on the side of edge impulse tools and Nano 33 BLE board.

In addition, the study shows that ML can be used to train ML models for the prediction of the quality leaf on an embedded device. The resulting model requires limited resources with the

simulation result showing the possibilities for embedded inference. The implementation of the proposed solution will help overcome the problem of limited datasets in agricultural sector. This will lead to better ML models and thus less dependent on livestock-keeping activities, wasting time and reducing operating costs of the livestock-keeping activities. In addition, the prediction of Quality leave using ML will ensure that the challenges of data processing will be solved.

6.2 RECOMMENDATIONS AND THE FUTURE WORK

As of today, the acquisition of rich open datasets is a big challenge in Africa. More data based on quality leaves could be collected using an embedded device such as the one designed in this Master Thesis. This project could be extended by incorporating ML algorithms for more quality leaves studies. Moreover, the extended system could be more informative, especially with the ability to capture Specific parameters of the Napier leaf. Furthermore, the device could be implemented in more sub-Saharan African rural regions, especially in East and Central Africa where livestock-keeping activities do well. Future works will involve the development of a more designed on-edge AI-dependent system for the improvement of scientific research based on livestock keeping especially those related to animal food such as differentiating anomalous characters of leaf behaviours.

REFERENCES

- [1] Rutamu I., 2008. Investment opportunities in the dairy sub-sector of Rwanda. SNV (Netherlands development organisation) & IFAD (International fund for agricultural development) report. Kigali.
- [2] SYB. 2015. Rwanda Statistical Yearbook 2015. Republic of Rwanda, National Institute of Statistics of Rwanda, Kigali. <http://www.statistics.gov.rw/publication/statistical-yearbook-2015>.
- [3] Ambar, A.R. and Djajanegara, A. 1982. The effect of urea treatment on the disappearance of dry matter and fibre of rice straw from nylon bags. In: The utilization of Fibrous Agricultural Residues as Animal Feed (ed. P.T. Doyle). University of Melbourne Printing Service. Parkville, Australia. pp 81-86.
- [4] D’Mello, J.P.F. 2011. Contaminants and toxins in animal feeds. FAO Animal Production and Health Paper, pp. 128.
- [5] Minoli D, Sohraby K, Kouns J. IoT security (IoTSec) considerations, requirements, and architectures. In: Proc. 14th IEEE annual consumer communications & networking conference (CCNC), Las Vegas, NV, USA, 8–11 January 2017. <https://doi.org/10.1109/ccnc.2017.7983271>.
- [6] Z. Xiang and D. R. Fesenmaier, “Big data analytics, tourism design and smart tourism,” in *Analytics in smart tourism design*. Springer, 2017, pp. 299–307.
- [7] J. Ateudjieu et al., “Health facility preparedness for cholera outbreak response in four cholera-prone districts in Cameroon: A cross-sectional study,” *BMC Health Serv. Res.*, vol. 19, no. 1, Jul. 2019, doi: 10.1186/S12913-019-4315-7/TABLES/2.
- [8] Kohli, A., Kohli, R., Singh, B., & Singh, J. (2020). Smart plant monitoring system using IoT technology. In *Handbook of Research on the Internet of Things Applications in Robotics and Automation* (pp. 318-366). IGI Global.
- [9] Duan, Haihan, Jiaye Li, Sizheng Fan, Zhonghao Lin, Xiao Wu, and Wei Cai. ”Metaverse for social good: A university campus prototype.” In *Proceedings of the 29th ACM International Conference on Multimedia*, pp. 153-161. 2021.
- [10] Jayme Garcia Arnal Berbedo, "A Review on the Main Challenges in Automatic Plant Disease Identification Based on Visible Range Images,". Av. André Tosello, 209 - C.P. 6041 - Campinas, SP - Brazil - 13083-886.
- [11] Farrell, G., Simons, S.A., Hillocks, R.J., 2002a. *Ustilago kamerunensis* on Napier grass in Kenya. *Int. J. Pest Manag.* 48 (1), 25e28.
- [12] Cook, S.M., Khan, Z.R., Pickett, J.A., 2007. The use of ‘push-pull’ strategies in integrated pest management. *Annu. Rev. Entomol.* 52, 375e400.
- [13] IRPCM Phytoplasma/Spiroplasma working team e Phytoplasma Taxonomy Group, 2004. ‘Candidatus Phytoplasma’, a taxon for the wall-less, non helical prokaryotes that colonize plant phloem and insects. *Int. J. Syst. Evol. Microbiol.* 54, 1243e1255.
- [14] Orodho, A.B., 2006. The Role and Importance of Napier Grass in the Smallholder Dairy Industry in Kenya. Retrieved January 16, 2015, from. http://www.fao.org/ag/agp/agpc/doc/newpub/napier/napier_kenya.htm.

- [15] Kabirizi, J., Nielsen, S.L., Nicolaisen, M., Byenkya, S., Alicai, T., 2007. Napier stunt disease in Uganda: farmers' perceptions and impact on fodder production. In: African Crop Science Conference Proceedings. El-minia, Egypt: Afr. Crop Sci. Conf. Proc., vol. 8, pp. 895e897.
- [16] MINAGRI. 2013. Final Report: National Dairy Stratey. Ministry of Agriculture and Animal Resources (MINAGRI), Republic of Rwanda.
- [17] R. Nukala, K. Panduru, A. Shields, D. Riordan, P. Doody, J. Walsh, Internet of things: A review from farm to fork, in: 2016 27th Irish Signals and Systems Conference (ISSC), 2016, pp. 1–6, doi: 10.1109/ISSC.2016.7528456.
- [18] S. Kanchana: "IoT in Agriculture: Smart Farming", International Journal of Scientific Research in Computer Science Engineering and Information Technology, December 2018.
- [19] Kohli, A., Kohli, R., Singh, B., & Singh, J. (2020). Smart plant monitoring system using IoT technology. In Handbook of Research on the Internet of Things Applications in Robotics and Automation (pp. 318-366). IGI Global.
- [20] M. L. Williams, N. Mac Parthalaen, P. Brewer, W. P. J. James, and M. T. Rose, " A novel behavioral model of the pasture-based dairy cow from GPS data using data mining and machine learning techniques," J. Dairy Sci., vol, Volume 99, no. Issue 3, pp. 2063-2075, 2016.
- [21] R. Dutta, et al., "Dynamic cattle behavioural classification using supervised ensemble classifies," Comput. Electron, Agric., no. 111,pp. 18-28, 2014.
- [22] C. Umstatter, A. Waterhouse, and J. P. Holland, "An automated sensor-based method of simple behavioural classification of sheep in extensive systems, " Comput. Electron Agri.,vol, 64, no. 1, pp, 19-26, Nov 2008.
- [23] WCED, Our Common Future, Oxford University Press, 1987.
- [24] Singh, R., Srivastava, S., & Mishra, R. (2020, February). AI and IoT-Based Monitoring System for Increasing the Yield in Crop Production. In 2020 International Conference on Electrical and Electronics Engineering (ICE3) (pp. 301-305). IEEE.
- [25] Clark, W. C., and Dickson, N. M., Sustainability science, the emerging research program. Proc. Natl. Acad. Sci. USA, 2003, 100, 8059–8061.
- [26] Siddagangaiah, S. (2016). A novel approach to IoT-based plant health monitoring system. Int. Res. J. Eng. Technol, 3(11), 880-886.
- [27] Ezhilazhahi, A. M., & Bhuvanewari, P. T. V. (2017, May). IoT enabled plant soil moisture monitoring using wireless sensor networks. In 2017 Third International Conference on Sensing, Signal Processing and Security (ICSSS) (pp. 345-349). IEEE.
- [28] Ragavi, B., Pavithra, L., Sandhiyadevi, P., Mohanapriya, G. K., & Harikirubha, S. (2020, March). Smart Agriculture with AI Sensor by Using Agrobot. In 2020 Fourth International Conference on Computing Methodologies and Communication (ICCMC) (pp. 1-4). IEEE.

- [29] Pavel, M. I., Kamruzzaman, S. M., Hasan, S. S., & Sabuj, S. R. (2019, February). An IoT-based plant health monitoring system implementing image processing. In 2019 IEEE 4th International Conference on Computer and Communication Systems (ICCCS) (pp. 299-303). IEEE.
- [30] L. A. Gonzalez, G. J. Bishop-Hurley, R. N. Handcock, and C. Crossman, "Behavioral classification of data from collars containing motion Sensor in grazing cattle," *Comput. Electron Agri.*, no. 110, pp, 91-102, 2015.
- [31] M. L. Williams, N. Mac Parthalaein, P. Brewer, W. P. J. James, and M. T. Rose, " A novel behavioral model of the pasture-based dairy cow from GPS data using data mining and machine learning techniques," *J. Dairy Sci.*, vol, Volume 99, no. Issue 3, pp. 2063-2075, 2016.
- [32] R. Dutta, et al., "Dynamic cattle behavioural classification using supervised ensemble classifiers," *Comput. Electron, Agric.*, no. 111, pp. 18-28, 2014.
- [33] H.S. Abdullahi , F. Mahieddine , R.E. Sheriff, Technology impact on agricultural productivity: A review of precision agriculture using unmanned aerial vehicles, in: P. Pillai, Y.F. Hu, I. Otung, G. Giambene (Eds.), *Wireless and Satellite Systems*, Springer International Publishing, Cham, 2015, pp. 388–400.
- [34] L. A. Gonzalez, G. J. Bishop-Hurley, R. N. Handcock, and C. Crossman, "Behavioral classification of data from collars containing motion Sensor in grazing cattle," *Comput. Electron Agri.*, no. 110, pp, 91-102, 2015.
- [35] Kabirizi, J., Nielsen, S.L., Nicolaisen, M., Byenkya, S., Alicai, T., 2007. Napier stunt disease in Uganda: farmers' perceptions and impact on fodder production. In: *African Crop Science Conference Proceedings*. El-minia, Egypt: Afr. Crop Sci. Conf. Proc., vol. 8, pp. 895e897.
- [36] Nguyen, Trong & Tat Thang, Nguyen & Nguyen, Van & Cao, Chi & Hua, Jun. (2019). Application of Arduino Control Mainboard with Color Light Sensor TCS3200 in Color Recognition of Edge Banding In Laser Edge Banding Machine. *IOP Conference Series: Earth and Environmental Science*. 252. 022130. 10.1088/1755-1315/252/2/022130.
- [37] Gay, W. (2018). DHT11 sensor. In *Advanced Raspberry Pi* (pp. 399-418). Apress, Berkeley, CA.
- [38] Singh, P., & Saikia, S. (2016, December). Arduino-based smart irrigation using water flow sensor, soil moisture sensor, temperature sensor and ESP8266 WiFi module. In 2016 IEEE Region 10 Humanitarian Technology Conference (R10-HTC) (pp. 1-4). IEEE.
- [39] S. V. Thomsen, A. Abileah, Y. Byun, and P. Weindorf, "AMLCD image retention issues for avionics applications," *Proc. SPIE Conf. on Cockpit Displays V*, pp. 189-197, 1998.
- [40] S. K. Ng, K. H. Loo, Y. M. Lai, Chi K. Tse. Color Control System for RGB LED With Application to Light Sources Suffering From Prolonged Aging. *IEEE Transactions on Industrial Electronics*, 61(4), 1788-1798. DOI:10.1109/TIE.2013.2267696 2014.
- [41] Dutta, S., Chaudhuri, B.: A Color Edge Detection Algorithm in RGB Color Space. In: *Proc. International Conference on Advances in Recent Technologies in Communication and Computing*. pp. 337 - 340, (2009).
- [42] Chen, H.: A novel color edge detection algorithm in RGB color space. In: *Proc. IEEE 10th International Conference on Signal Processing (ICSP)*, (2010).

- [43] “Nano 33 BLE Sense | Arduino Documentation | Arduino Documentation.” <https://docs.arduino.cc/hardware/nano-33-ble-sense> (accessed Jul. 29, 2021).
- [44] “16x2 LCD Pinout Diagram | Interfacing 16x2 LCD with Arduino.” <https://www.electronicsforu.com/technology-trends/learn-electronics/16x2-LCD-pinout-diagram> (accessed Aug. 01, 2021).
- [45] Walczak, S. (2019). Artificial neural networks. In *Advanced Methodologies and Technologies in Artificial Intelligence, Computer Simulation, and Human-Computer Interaction* (pp. 40-53). IGI Global.
- [46] Quek, S. G., Selvachandran, G., Munir, M., Mahmood, T., Ullah, K., Son, L. H., ... & Priyadarshini, I. (2019). Multi-attribute multi perception decision-making based on generalized T-spherical fuzzy weighted aggregation operators on neutrosophic sets. *Mathematics*, 7(9), 780.
- [47] McCulloch, W. S., & Pitts, W. (1943). A logical calculus of the ideas immanent in nervous activity. *The bulletin of mathematical biophysics*, 5(4), 115-133.
- [48] Hebb, D. O. (1949). *The organization of behavior: a neuropsychological theory*. J. Wiley; Chapman & Hall.
- [49] Gholami, R., & Fakhari, N. (2017). Support vector machine: principles, parameters, and applications. In *Handbook of Neural Computation* (pp. 515-535). Academic Press.
- [50] Martínez-Ramón, M., & Christodoulou, C. (2005). Support vector machines for antenna array processing and electromagnetics. *Synthesis Lectures on Computational Electromagnetics*, 1(1), 1-120.
- [51] Kecman, V., & Wang, L. (2005). *Support vector machines: theory and applications*.
- [52] Devroye, L. (1981) "On the equality of Cover and Hart in nearest neighbor discrimination", *IEEE Trans. Pattern Anal. Mach. Intell.* 3: 75-78.
- [53] Devroye, L., Györfi, L., Krzyżak, A. & Lugosi, G. (1994) "On the strong universal consistency of nearest neighbor regression function estimates", *Ann. Statist.*, 22: 1371–1385.
- [54] Devroye, L. & Wagner, T.J. (1977) "The strong uniform consistency of nearest neighbor density estimates", *Ann. Statist.*, 5: 536–540.
- [55] Devroye, L. & Wagner, T.J. (1982) "Nearest neighbor methods in discrimination, In *Classification, Pattern Recognition and Reduction of Dimensionality*", *Handbook of Statistics*, 2: 193–197. North-Holland, Amsterdam.
- [56] <https://www.cipd.co.uk/knowledge/strategy/organisational-development/pestle-analysis-factsheet#gref>.

APPENDICES

Appendix 1: Project programming codes on ML testing data

```
/* Includes ----- */
#include <Quality_Leaf_IoT_Assessment_System_inferencing.h>

static const float features[] = {
23.4000, 73.0000, 127.0000, 60.0000, 0.0000
    // copy raw features here (for example from the 'Live classification' page)
    // see https://docs.edgeimpulse.com/docs/running-your-impulse-arduino
};

/**
 * @brief      Copy raw feature data in out_ptr
 *             Function called by inference library
 *
 * @param[in]  offset   The offset
 * @param[in]  length   The length
 * @param      out_ptr  The out pointer
 *
 * @return     0
 */
int raw_feature_get_data(size_t offset, size_t length, float *out_ptr) {
    memcpy(out_ptr, features + offset, length * sizeof(float));
    return 0;
}

/**
 * @brief      Arduino setup function
 */
void setup()
{
    // put your setup code here, to run once:
    Serial.begin(115200);
    // comment out the below line to cancel the wait for USB connection (needed
for native USB)
    while (!Serial);
    Serial.println("Edge Impulse Inferencing Demo");
}
```

```

/**
 * @brief      Arduino main function
 */
void loop()
{
    ei_printf("Edge Impulse standalone inferencing (Arduino)\n");

    if (sizeof(features) / sizeof(float) != EI_CLASSIFIER_DSP_INPUT_FRAME_SIZE) {
        ei_printf("The size of your 'features' array is not correct. Expected %lu
items, but had %lu\n",
                EI_CLASSIFIER_DSP_INPUT_FRAME_SIZE, sizeof(features) /
sizeof(float));
        delay(1000);
        return;
    }

    ei_impulse_result_t result = { 0 };

    // the features are stored into flash, and we don't want to load everything
into RAM
    signal_t features_signal;
    features_signal.total_length = sizeof(features) / sizeof(features[0]);
    features_signal.get_data = &raw_feature_get_data;

    // invoke the impulse
    EI_IMPULSE_ERROR res = run_classifier(&features_signal, &result, false /*
debug */);
    ei_printf("run_classifier returned: %d\n", res);

    if (res != 0) return;

    // print the predictions
    ei_printf("Predictions ");
    ei_printf("(DSP: %d ms., Classification: %d ms., Anomaly: %d ms.)",
        result.timing.dsp, result.timing.classification, result.timing.anomaly);
    ei_printf(": \n");
    ei_printf("[");
    for (size_t ix = 0; ix < EI_CLASSIFIER_LABEL_COUNT; ix++) {
        ei_printf("%.5f", result.classification[ix].value);
#ifdef EI_CLASSIFIER_HAS_ANOMALY == 1
        ei_printf(", ");
#else
        if (ix != EI_CLASSIFIER_LABEL_COUNT - 1) {
            ei_printf(", ");
        }
}
}

```

```
#endif
    }
    #if EI_CLASSIFIER_HAS_ANOMALY == 1
        ei_printf("%.3f", result.anomaly);
    #endif
    ei_printf("]\n");

    // human-readable predictions
    for (size_t ix = 0; ix < EI_CLASSIFIER_LABEL_COUNT; ix++) {
        ei_printf("  %s: %.5f\n", result.classification[ix].label,
result.classification[ix].value);
    }
    #if EI_CLASSIFIER_HAS_ANOMALY == 1
        ei_printf("  anomaly score: %.3f\n", result.anomaly);
    #endif

    delay(1000);
}
```