

Analysis of Transformer failure due to lightning on Haugaland Kraft power line distribution network

JOSEE MUSABYIMANA

Supervisors

Assoc. Prof. *Thomas Gjesteland*

Prof. Mohan Lal Kolhe

This master's thesis is carried out as a part of the education at the University of Agder and is therefore approved as a part of this education. However, this does not imply that the University answers for the methods that are used or the conclusions that are drawn.

University of Agder, 2016
Faculty of Engineering and Sciences
Department of Renewable Energy

Abstract

The transformer plays an important role in transmission and distribution of electric energy. A lightning causes a seriously problems in damaging electrical line equipments such as transformers. The Haugaland Kraft transformers were damaged due to the thunderstorms. When lightning strikes direct or indirect to the power line, the electrical pulse travels along the conductor, generating a very high additional current in the power line distribution network which in turn leads to an overvoltage. The transformer failure was caused by the higher lightning energy exceed the withstand capability of the power line equipment.

The improvement to the protection of the distribution transformer was based on the analysis of parameters which will help to reduce the induced overvoltages. The best method was found to be the placement of the protective equipments in the power line and the selection of the surge arrester which is the main material used in protecting transformer. This analysis resulted into consideration of improving the significance parameters which will help to reduce the induced lightning voltage. There will be needed the installation of OGW and the selection of surge arrester residual voltage. The use of a new surge protective called Strikesorb must be used to protect the transformers against lightning strikes. The distance from the protected transformer to the surge arrester must be considered in order for the transformer to be protected.

Keywords: Thunderstorm, Lightning, overvoltage, induced overvoltage, power line distribution network, lightning protections, transformer failures, power outages

Acknowledgement

I would like to express my deepest appreciation to my supervisors Assoc. Prof. Thomas Gjesteland and Prof. Mohan Lal Kolhe for encouraging me to complete this thesis. My efforts for this thesis would have not been possible without their motivation, guidance as well as continuous support. I could not have imagined having better supervisors and mentors for my masters' thesis.

We would like to extend my gratitude towards my husband Sosthene Kazima for his constant encouragement which helped me in completion of this work. Last but not the least, my special thanks also go to my fellows in developing the project and all the people of University of Agder who have willingly helped me out with their abilities.

Josee Musabyimana

University of Agder

Grimstad, 18th May 2016

List of figures

Figure 2.1:Development of thunderstorms[4].....	7
Figure 2.2:The global annual distribution of lightning activity (<i>flashes/km²year</i>) [14].....	8
Figure 2.3: The attraction of positive and negative charges to form lightning [1]	10
Figure 2.4:Lightning generation shows 1) Cloud and ground charges, 2) Charge separation and stepped leader formation, 3) Return stroke in terms of lightning flash [28].....	11
Figure 2.5:shown the types of cloud discharges[8].	12
Figure 2.6. ATDnet lightning data 2008-2012 for Europe(all 12 Months) [11].....	14
Figure 2.7. ATDnet lightning data 2008-2012 for Europe(only in July) [11]	14
Figure 2.8.Photo taken from you tube	15
Figure 2.9 shows that the probability distributions of the negative first return stroke are higher than that of subsequent stroke from (2.8) & (2.9).....	20
Figure 2.10 Cumulative statistical and corresponding log-normal distributions of the return-stroke peak current measured at a tower top for 1. negative first strokes, 2. negative subsequent strokes, and 3. positive first strokes[10].....	22
Figure 2.11. Direct strike to 1. a tower; 2.shield wire and 3. phase conductor [5].....	24
Figure 2.12. unshielded direct lightning on phase conductor [7]	25
Figure 2.13 shows the wave shape of the return stroke current from equation (2.10) which was recommended by IEC [57].....	26
Figure 2.14Lightning channel striking to the tower top due to unshielded power line[3].....	29
Figure 2.15.Traveling wave due to lightning strikes a shield wire[4]	30
Figure 2.16.The current passes along the tower to the ground [4]	30
Figure 2.17: Stroke current due to lightning strikes to a tower top [3, 15, 16].....	31
Figure 2.18.Shielding analysis in power line taken from [63, 64].....	33
Figure 2.19. A lightning strike nearby a grounded power line[3]	35
Figure 2.20.The charged clouds induced electromagnetics to the power line[3]	35
Figure 2.21: Electro-geometric model for estimating the least distance of ground strike[71]	37
Figure 2.22: Line parameters and lightning stroke relative position[13].....	37
Figure 2.23: Shows the heights above the earth in power line [62] to some parameters from (2.26 & 2.28).	41
Figure 2.24: Experiment results from[9] for comparing the protections of an overhead direct strike with SA and combining both SA and OGW at difference spacing interval between arresters relative to the arrester grounding resistance	48
Figure 2.25: EMTP software results from[12] in the analysis of induced voltage in the power line due to lightning transient by using SA, OGW and combinations of SA and OGW	49

Figure 2.26. The outage ratio due to direct and indirect lightning by the use of OGW, SA as well as the use of combinations of OGW &SA	50
Figure 2.27: For a pole mounted transformer placed on tower in power line [6].....	53
Figure 2.28: For a Pad mount transformer [2]	53
Figure 2.29: For calculations separations distance between surge arrester and transformer	54
Figure 2.30: The probability distributions of lightning current strike to phase conductor which is nearly connected to the transformer (2.57)	55
Figure 2.31: Shown the different variation method for protecting a transformer using the arrester	58
Figure 2.32: Pole mounted transformer	59
Figure 2.33: Pad mounted transformer	59
Figure 2.34: Application of using arrester to the primary and secondary system protection	60
Figure 3.1: Showing the locations (inside of red color) of Haugaland Kraft power line distributions networks.....	62
Figure 4.1: Was plotted reference to the data of the Haugaland Kraft power line showing the numbers of transformers failures due to thunderstorms from the years 2009 up to 2015 with respect to months	64
Figure 4.2: Showing the number of lightning stroke in the location of Haugaland Kraft power line from 2009 up to 2013 & 2015 relative to the yearly months.....	65
Figure 4.3: Transformers failures due to the lightning peak current distributions in the Haugaland Kraft power line as function of Months.....	65
Figure 4.4: Showing the number of positives and negatives lightning distributions which they had the effects on Haugaland Kraft transformers failures for power line distribution networks in the period from 2009 up to 2013 & 2015	66
Figure 4.5: The distributions of lightning current ratio caused transformers failures of Haugaland Kraft power line as function of Months.....	67
Figure 4.6: Average absolute lightning peak current provided in thunderstorms in the Haugaland Kraft power line as function of Months cause transformers failures.....	67
Figure 4.7: The average induced voltage when lightning strike to tower for unshielded power line with 17kA.....	69
Figure 4.8: The maximum induced voltage when lightning strike to tower for unshielded power line with 267kA.....	69
Figure 4.9: The average induced voltage when lightning strike to the phase conductor for unshielded power line with 17kA.....	70
Figure 4.10: The maximum induced voltage when lightning strike to the phase conductor for unshielded power line with 267kA	70
Figure 4.11: The average induced voltage when lightning strike to the shielded power line with 17kA.....	70

Figure 4.12: The maximum induced voltage when lightning strike to the shielded power line with 17kA.....	70
Figure 4.13: The average induced voltage when lightning strike nearby grounded power line with 17kA by considering the distance between power line and striking object.....	71
Figure 4.14: The average induced voltage when lightning strike nearby grounded power line with 17kA by increase the tower height.....	71
Figure 4.15: The average induced voltage when lightning strike nearby grounded power line with 17kA by increase the soil resistivity.	71
Figure 4.16: The maximum induced voltage when lightning strike nearby grounded power line with 267kA by considering the distance between power line and striking object.....	71
Figure 4.17: The maximum induced voltage when lightning strike nearby grounded power line with 267kA by increase the tower height.	72
Figure 4.18: The maximum induced voltage when lightning strike nearby grounded power line with 267kA by increase the soil resistivity.	72
Figure 4.19: The outage rate due to direct strike for unshielded and shielded power line with the average lightning current of 17kA at 100m span length with 100km line length.....	73
Figure 4.20: The outage rate due to direct strike for unshielded and shielded power line with the average lightning current of 17kA at 100m span length with 200km line length.....	73
Figure 4.21: The outage rate due to direct strike for unshielded and shielded power line with the average lightning current 17kA at 200m span length	73
Figure 4.22: The outage rate due to direct strike for unshielded and shielded power line with the maximum lightning current 267kA at 100m span length	73
Figure 4.23: The outage rate due to direct strike for unshielded and shielded power line with maximum lightning current 267kA at 100m span length	73
Figure 4.24: The outage rate due to direct strike for unshielded and shielded power line with maximum lightning current 267kA at 200m span length	73
Figure 4.25: The outage rate due to indirect strike to the power line with the average lightning current 17kA at 100m span length	74
Figure 4.26: The outage rate due to indirect strike to the power line with maximum lightning current 267kA at 100m span length	74

List of tables

Table 2.1: Transformer and power line parameters	56
Table 2.2: Thunder day and GFD parameters.....	56
Table 2.3: Shows calculated value of l at $x=300\text{m}$ and $Ng = 6.9$	56
Table 3.1: Showing the provided periods for lightning stroke distributions data from Norwegian Meteorological Institute at the location of Haugaland Kraft power line from 2009 up to 2013 & 2015	62
Table 4.1: Showing the power line and lightning parameters	69

Table of Contents

Abstract	i
Acknowledgement	ii
List of figures	iii
List of tables.....	vi
List of abbreviations and acronyms	ix
List of notations	xi
1 Introduction	1
1.1 Background and motivation.....	2
1.2 Problem statement	3
1.3 Objectives and limitations	4
1.4 Thesis outline.....	4
2 Theory and background.....	6
2.1 Thunderstorms in power line	6
2.2 Lightning structure.....	9
2.2.1 Lightning Generation	10
2.2.2 Types of lightning discharge	12
2.2.3 Lightning and Thunderstorms in Norway	13
2.2.4 Main Parameters in Lightning strike	15
2.3 The different types of lightning current strike to the power line	20
2.3.1 Effect of lightning in Power Line.....	23
2.4 Calculations of outages rate caused by effect of lightning strike in the power line ..	38
2.4.1 Outage rate caused by direct to phase conductor unshielded power line.....	39
2.4.2 Outages rate caused by direct strike to a tower unshielded power line.....	41
2.4.3 Outage rate caused by direct strike to shielded power line	42
2.4.4 Outages rate caused by indirect effect to the power line.....	42
2.5 Lightning overvoltages in power line networks	43
2.5.1 High Voltage Transmission Network Lightning protection.....	44
2.5.2 Medium and Low Voltage Lightning Protection	47
2.5.3 Assessment of lightning transformer failures and protections	51
3 Data collections and Method	61
3.1 Haugaland Kraft transformer failure data.....	61
3.2 Lightning data	62
3.3 Data analysis.....	63
4 Results analysis	64
4.1 Collected data observations	64
4.2 Results from the literature review.....	67
4.2.1 The main parameters for preventing transformers failures due to lightning effects	68
5 Discussion.....	75

6	Conclusion and Recommendations	77
7	References	79
	Appendix.....	86

List of abbreviations and acronyms

ATDnet: Arrival Time Differing NETWORK

BIL: Basic Impulse Insulation Level

CFO: Crucial impulse Flashover voltage

CG: cloud-to-ground discharge

CIGRE: Conseil International des Grands Réseaux Électriques

CRIEPI: Central Research Institute of Electric Power Industry

DH: Direct lightning Hits

ELF: Extremely Low Frequency

EM: Electromagnetic field

EUCLID: European Cooperation for Lightning Detection

Fig: Figure

HV: High Voltage

IC: Intra- Cloud flash

IEC: International Electrotechnical Commission

IEEE: *Institute of Electrical and Electronics Engineers*

IO: Induced Overvoltage

KHz: Kilo Hertz

LF: Lifetime

LFC: lightning Flash Counters

LLS: Lightning Location System

LPS: Lightning Protection System

LV: Low Voltage

MCOV: maximum continuous operating voltage

MOV: Metal Oxide Varistor

MTBF: Mean Time Between Failures

MV: Medium Voltage

NLDN: National Lightning Detection Network

NVE: Norwegian Water Resource and Energy Directorate

OGW: Overhead Ground Wire

OHGW: Overhead ground wires

SA: Surge Arrester

SPD: Surge Protection device

TH: Thunderstorm-Hour

UHF: Ultra high frequency

UK: United Kingdom

VHF: very high frequency radiation location system

List of notations

σ_{lnI_p} and σ_{lnI_f} : are the standard deviations of lnI_p , and lnI_f respectively

°C: Celsius degree

°N: latitude degree on the North

°S: Longitude degree on South

μ s: Microsecond

A: Ampere

A: attractive area which could cause a flashover in power line

A_p : area of the phase conductor

A_t : the attractive area of the tower

b: effective width at the horizontal distance between overhead shield wires

Bo: distance between the line and the lightning strike

B_{peak} : peak magnetic induction

c: velocity of light in free space

C: capacitance

C: coulomb

CC: cloud to cloud discharge

d: distance between the outer most 2 conductors

D_C : horizontal shielding failure exposure distance

d_p : separation distance between two outermost conductors

E_{peak} : electric field peak

E_{ei} : electric field due to charge of the lightning stroke

E_i : induced Electric field

E_{mi} : electric field due to the return stroke current

$erfc(u)$: the complimentary error function of u

E_t : the peak surge voltage at transformer in kV

f: proposed factor

F_{MV} : transformer failure rate caused by direct stroke to the MV overhead power line

FR_p : Arrester failure rate

F_T : transformer failure rate caused direct stroke to the object connected to the LV side

g: gram

h: height above the ground

h: hour

h : the line height in meters

h_p : the height of the conductor at tower

h_s : shield wire height

h_t : height of tower

$I(t)$: the lightning return stroke current in function of time

$i(t)$: the discharge current through the arrester in kA

I: Current will cause flashover

I_{AM} : The maximum arrester current

I_c : critical return stroke current value

I_{FT} : critical current to cause the flashover on LV transformer side

I_{MSF} : maximum shielding failure lightning current in kA

I_p : lightning stroke current

I_{pm} : median values of return stroke current

I_T : Return stroke current

k : corona-damping constant in $\mu s/kVm$

kA: kilo-Ampere

Km: kilometer

Km²: kilometer square

kV: Kilo Volt

kVA: Kilo volt Ampere

L : Inductance

l : length of power line in km

$\ln I_p$: natural logarithm of I_p

l_s : span length

m: meter

mm: millimeter

n : = reflected wave point

N: Number of direct flashes in power line

N_{BF}: Back flashover

N_f: The number of direct stroke to the distribution line

nfp: outages rate of unshielded power line

nfpo: the number of outages for lightning strokes falling within to the attractive area of the phase conductor

N_g: Ground Flash Density of lightning or number of stroke per km²/year

N_{MV}: the rate of direct lightning flashes to the MV overhead power line

N_{sg}: Ground Strike-point density

n_{sp}: the number of span per 100 km

N_T: the rate of direct lightning flashes to the tower

N_t: the total (CG + CC) density of optical flashes per km² per year.

$p(t_f)$: probability density function of front time

$p(I_p)$: the probability density function for the return stroke current

P: probability distribution of the first and subsequent negative return stroke

Pc(Ic): cumulative probability of return stroke current

Q: electric Charge

R: Earthing Resistance

R: radius of a tower base

R_{ai}: impulse resistance of arrester earth rod (Ω)

R_{eqT}: the interception radius of the tower

r_g: striking distance to the ground (m)

r_s: striking distance to the line conductor

R_{gf}: grounded resistance

S: second

S_f: Shielding factor

T: tail time constant

T₁: the time constant determine the current-rise time

T₂: the time constant determine the current-decay time

T_d: thunder days or keraunic level which is the average number of days per year the thunder

t_f: the return stroke front time in μs ,

t_o: the moment when lightning strikes the surge arrester terminal

t_s : the duration between two lightning surges which cause damage to the transformer (year)
 U_p : the residual voltage across the surge arrester in kV
 $V(t)$: Traveling voltage wave
 v : velocity of the return stroke
 v : velocity of wave propagation
 V : Voltage
 V_{FO} : flashover voltage
 V_{ins} : insulator voltage
 V_P : maximum voltage lightning strokes induced in power line
 V_R : indirect induced voltage by considering a perfect soil
 v_r : the relative velocity of the return stroke
 V_s : indirect induced voltages include the contribution of finitely conducting soil
 V_T : shield-wire voltage
 W : Energy
 y : the interval distance between a grounded power line and lightning striking an object
 Y_{min} : minimum distance between a tall object and overhead power line
 Z_p : surge impedance of the line
 Z_{ph} : Impedance of Phase Conductor
 Z_t : Surge tower Impedance
 α : shielded angle
 β : the transformer reflection coefficient
 \mathfrak{S} : correction factor of the lightning current
 ρ : soil resistivity
 Ω : Ohm

1 Introduction

An electric power system presents a significant role in modern society as well as in the growth of country economy where it is utilized in the industries, households and the commercial sector. The power outage affects human life activities and the economic performance of a country. The growing use of sensitive electronic equipment and the increasing demand of utility customers, demonstrate that the stability of the power supply have highlighted as importance of optimizing the reliability and power quality levels of electric systems[15]. The failures of electric power system could be caused by internal differences and external disturbances. A lightning is a major root of faults occurring on overhead power lines and destroys or disrupt of sensitive electronic equipment, it is necessary to evaluate and protect the lightning electromagnetic transient effects in order to optimize the power system quality[17]. Transformers are one the most equipment in power line significantly failures due to lightning. The general cause of transformer power cut or rather failures is lightning strikes to or proximity distribution lines[18]. The Haugaland Kraft power line as the case study of transformers protections which they have more outages from 2009 up to 2015 due to the lightning strike which caused transformers failures.

Haugaland Kraft is one of Norway Energies Company situated in western country, in which transmit and distribute electrical energy to the household, industrial and government sectors at 770km of power line. Some of their transformers have failed to function because of thunderstorms, which cause outage of a power line. Based, on the significant role that transformers present in transmission and distribution of electric power which is step up or step down of voltage and current amplitude, and regarding to its highest cost and repair complexity, this indicate the reason why it needs an adequate protection against lightning. In the research thesis, I have focused on analysis of lightning protection performance of Haugaland Kraft's distribution transformers damaged by thunderstorms effects. The transformers were installed as pole and pad mounted and have different power which vary between 50kVA up to 315kVA, voltage 23kV or 22kV on primary side (MV) and 240V on secondary side (LV) i.e. step down transformers. Most of these transformers have been protected by surge arrestor at transformer MV and Raychem 280/Raychem Metal-Oxide Low Voltage Arresters and Varistor at transformer LV. Its line was partial shielded i.e. shielded 0-500m from where transformer installed in order to optimize transformer protections but still failure due to the thunderstorms.

The environment condition is one of the most important considerations when constructing, designing equipments and protecting a power line. The NVE (Norwegian water resources and energy directorate) report , 2011 [19] had demonstrate that the lighting frequency and thunderstorms will increase of 25% towards 2050, with an uncertainty range from 0 to 50% increase by expecting further increase until the year 2100 with the increase temperature and precipitation in comparison with in the years of 1960-1991. During the research thesis, the improvement performance protections of the distributed transformers from Haugaland Kraft will be analyzed based on different types of protections provided by the company relative to the power lines constructions, protections, equipments standard requirements and the meteorology or environment conditions of the area where transformers are located.

1.1 Background and motivation

Lightning and thunderstorms have been the most challenge in design of insulation system of electrical power systems and it is the principal cause of outages in transmission and blackout in distribution lines.

They are the main causes the world of power line disturbance, utility outages, and fires, and others damages [4]. Lightning affects buildings in the form of directly and indirectly. Direct effects include the burnout or even explosion of electrical power and distribution equipment which could be very expensive to repair[4]. Indirect effects are produced by the augmentations of ground voltage when lightning hits the earth, generating high electromagnetic fields. That may provoke voltage and current surges in electric power and signal circuits in the area which might result in burnout electrical equipment and line faults. Approximately one third of power line cut out are lightning related, according to Rakov[10]. A NVE report 2011, demonstrate that the main causes of malfunctions in the Norwegian power grid come from external factors such as thunderstorms and lightning, which count for 35-45% of all breakdowns in distribution network (1-22kV) and 30-40% in the regional and central grid (33-420kV). Due to this big problem, the Norway government regulation obligate the energy company to identify the need for emergency repairs to handle outcomes as a result of extraordinary events. In the earlier most researches including NVE found that lightning is a significant cause of power failure specifically transformers distribution network due to the Low insulation level in comparison to the high voltage transmission line. One of the most general risks power engineers must protect against flashovers, which can carry to an interruption of service. The research thesis on power line lightning protection will help Haugaland

Kraft energy company to improve protections to their distribution transformers where around 303 transformers from the range of year 2009 up to 2015 were destroyed due to thunderstorms. According to the lightning data from Norway metrology demonstrated that, the quantity of lightning frequency in the region where a Haugaland Kraft power line located were significantly increased in the range of year 2009-2015 consequently the power line outage. The future record of lightning data demonstrated also the raise of lightning frequency of 25% towards 2050, with an uncertainty range from 0 to 50% increase by expecting further increase until the year 2100. According to this record, all Norway energy company might pay attention for protecting its power line relative to the environment by considering the insulation level to withstand the high voltage capability.

1.2 Problem statement

Electrical engineers have taken more time for improving the manner to monitor lightning and power surges in the power line. Lightning produces the surge currents and overvoltages causing isolation deterioration in equipment and damaged power line equipment. If the powerline equipments are not well protected against the overvoltages, it will cause burning of insulation; the results of will be power outage in power line [8]. The effects of lightning stroke are classified in the type of direct lightning stroke, where it strikes direct to the power line and indirect lightning stroke where it strokes to the objet nearby a grounded power line but both of them increase the energy in the power line network which could destroy the power line equipment in case of the lightning generated exceed the tolerate capability of the power line. The transformer is the one of power line equipment which vulnerably destroyed by lightning strike because is directly connected to the phase conductors i.e. all transient disturbance could cause the transformer damage which is the important equipment in distributions of power energy to the consumers. The analysis of the transformer failure data showed that most of Haugaland Kraft's transformers damaged during the winter time Fig.4.4. In the literature winter storms typically have higher peak currents. However, analysis of the lighting data related to Haugaland Kraft transformer failure did not show a significant higher peak currents during winter time. As, the power is needed all the time, for every daily life time by the industrials, homeland, private and government sectors and especially in the period of winter time for homeland heating. Therefore, the absence of power could bring the death human being. In additional to that, according to the Haugaland Kraft electrical company record shown that more transformers were failure due to thunderstorms about

36 in 2009, 12 in 2010, 30 in 2011, 40 in 2012, 67 in 2013, 89 in 2014 and 33 in 2015 with the total of 303 transformers failures. This demonstrates the higher numbers of transformers breakdown which are very expensive and difficult to repair. Therefore, the company needs improvement to protect their transformers against lightning transient disturbance in order to work on stable conditions, saving cost for repair and maintenance and to save the people's life against the death caused by the cold in the absence of the power.

1.3 Objectives and limitations

Power line is the most used everyday life to conduct the electricity in the different areas such as industrial, commercial and household. The uninterrupted of electricity contribute a lot in the development of country. Transformers are the crucial parts of powers system which have a function of providing the final voltage transformation in the electric power distribution system, stepping down the medium voltage of lines to the voltage level using by the customer, for this the sophisticated protection is needed in their lifetime. Around 303 distributions transformers of the Haugaland Kraft Medium Voltage damaged from 2009 up 2015 due to the thunderstorms. These transformers are installed as pole and Pad mounted have 50 up 315kVA and 22k & 23kV in primary side (MV) and 240V in secondary side (LV) with 770km power line length. The research thesis will focus on transformers protection against lightning transient disrupt in order to optimize their performances ability to withstand the effect of lightning transient. The results of the transformers protections will base on:

- Preventing transformer against damage or heating due to the thunderstorms and lightning
- Preventing blackout (power off) to customers
- Decreasing the cost of maintenance caused by lightning strike
- Keeping a system to be stable and power line optimization
- Preventing distribution feeder against damage or heating
- Increasing equipment life
- Proposing of a new lightning protection of medium and low voltage networks

1.4 Thesis outline

Chapter 1 describes the introduction to the project and the problem description. Chapter 2 describes the literatures concerning the thunderstorm, lightning, effects of lightning to the power line, transformer failures and its protection. Chapter 3 describes the data collected from Haugaland Kraft and Norwegian Meteorological Institute. Chapter 4 consists of the results

obtained from the collected data and the data obtained from the literatures. Chapter 5 describes the discussion on the result analysis while recommendation and conclusion are described in chapter.

2 Theory and background

2.1 Thunderstorms in power line

A thunderstorms are one of the most disturbing and dangerous types of natural weather phenomena can kill peoples and damaged building materials. Each day, over 40,000 thunderstorms happen throughout the world. The factors engaging to create thunderstorms are warm air advection in the lower tropospheric, blocking of cold air advection by the mountains, accumulation of moisture at low levels and strong solar radiative heating of the earth's surface[20]. These factors are divided into three stage in development of thunderstorms which are: cumulus stage, mature stage, and dissipating stage.

Thunderstorms initially start by direct heating of moisture air at ground level by sun called convective thunderstorms. The heat warms the air around the surface. Since warm air become lighter than cool air, it begins to increase known as an updraft. when the air is moist, then the warm air condenses into a cumulus cloud. The cloud will continue to grow as long as warm air continues to rise. Since, the cumulus cloud becomes very large and heavy, then, the rain drops start to fall in the cloud. Because cool air is heavier than warm air, it begins to descend in the cloud known as a downdraft. The downdraft pulls the heavy water downward, making rain. The cloud become a cumulonimbus cloud because it has an updraft, a downdraft, and rain. Thunder and lightning start to occur, as well as heavy rain called thunderstorms.

Thunderstorms produced by a cumulonimbus cloud characterized sometimes with gusty winds, heavy rain, snow, lightning, tornadoes and hail which are the main factors may have effect on power lines [17]. After about the certain minutes, the thunderstorm begins to dissipate. This occurs when the downdrafts in the cloud begins to dominate over the updraft. Since warm moist air can no longer rise, cloud droplets can no longer form. Thus the cloud disappears from bottom to top. Fig.2.1 shows a development of a thunderstorm.

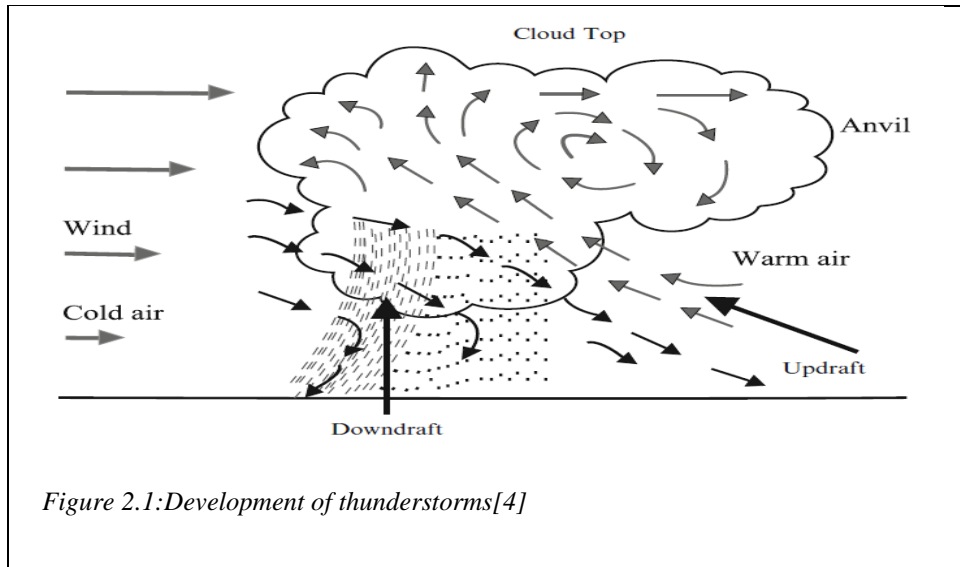

Thunderstorms are variable in higher intensity, dimensions, and electrical structure. Terrestrial thunderstorms show a link between lightning activity, strong vertical air currents, and the presence of precipitation. “Thunderstorms contain water drops and ice crystals, have water contents in around of 3 g per meter cube and have precipitation rates only particles larger than 100 μm in excess of 20 mm per hour”[21]. Lightning activity has been reported in clouds with precipitation rates lower than 10 mm per hour and it is observed at all latitudes between 60°N and 60°S Fig.2.2

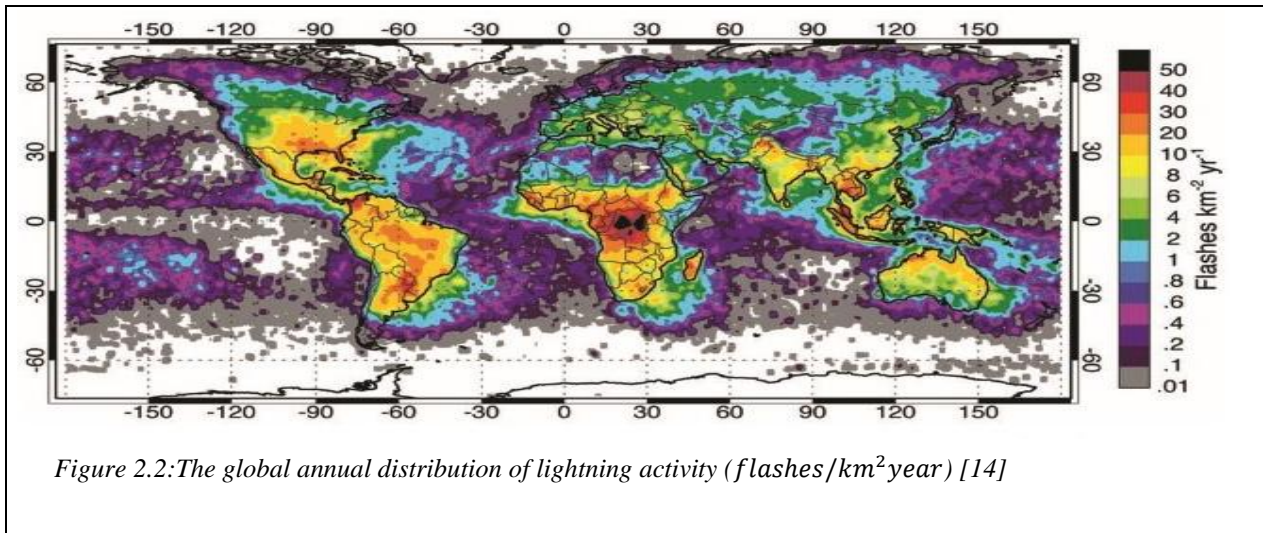

Lightning has been observed in clouds that are completely at subfreezing temperatures, but these clouds usually contain both super cooled water droplets and ice[21]. In the wide range of conditions under which lightning is generated in terrestrial clouds, it is possible to state that its occurrence is more probable in clouds with mixing ratios in excess of 3 g per meter cube and with relatively large cloud particles, and in clouds that contain both water and ice particles. Such clouds are convective with updrafts strong enough to be able to deviate the larger particles[21].

Thunderstorms are the source of lightning because of the electrical charges produced in the clouds. The clouds become electrically charged due to static electricity that builds up when the water molecules are bounced around inside the cloud. The stronger the updraft winds, the more lightning. The negative electrical charge builds up at the base of the cloud and a positive charge builds up on the ground. Since positive and negative charges attract they meet to form a bolt of lightning[22].

During the period of thunderstorms, there are a high number failures of electrical and electronic devices increases. The main reason for these failures is overvoltage in the wiring system caused by atmospheric discharges[23]. In the Fig.2.2, the number of flashes/km²year in Europe continental is in the range of 0.1 to 4 *flashes/km²year* which is the minimum number in comparison to these that had the above of 4 *flashes/km²year*[11]. “Power lines can failures even if the number of flashes/km²year are low when they pass through high-resistivity soils like deserts or when lines span across hills or mountains, where ground wire or lightning arrester

earthing become difficult”[3]. The protection against such failures is highly recommended by the use standard protection and equipments relative to long term environment variations.

2.2 Lightning structure

Lightning is the plain discharge of static electricity occurs into a cloud, between clouds, or between ground and a cloud as shown in Fig.2.3. Lightning current is the prior source for damages, disturbances and malfunctions in electrical power[24]. A very impressive phenomenon occurs in nature. It is considered as an electricity discharge from atmosphere, which characteristically happens during thunderstorms, volcanic eruption and dust storms. During the atmospheric discharge of thunderbolt may run, at speeds of 60,000 m/s i.e. 220,000 km/h, and can attain a temperatures approximately 30,000 °C it is five times hotter than the surface of the sun [25].

Lightning is the most spectacular event known as geographical phenomena. It generates the brightest flame and the loudest sound commonly occurring on Earth. Since virtually everyone has appeared lightning, there is 30–100 cloud and cloud to ground lightning discharges per second worldwide; that is, grossly 9 million discharges per day worldwide. Lightning appears randomly in space ,time and the wide range of its major time range, from tens of nanoseconds for many single processes to approximately a second for the whole discharge, and its obscuration by the thundercloud generating it makes lightning extra hard to analyze [26]. The total amount of energy produced during a lightning stroke is very high and it can be extremely deteriorative. Electric power networks are notably vulnerable to lightning strokes. A single stroke to a distribution line can be sufficient to provoke an outage throughout a feeder. Lightning is the principal cause for power outages in transmission and distribution lines. The lightning issue is defined as a transient event. When lightning hits a power line, it reacts as closing a “big switch” between a big current source amount and the power line circuit. The sudden closing of this “big switch” causes a rough variation in the circuit conditions by developing a transient. There is also the case when the lightning hits the proximity of the power line and the large magnetic field produced by the lightning current cause mutual linkage between the power line and the lightning. The event alters the conditions of the power line circuit, as a result, generating an electrical transient[27]. The protection system against lightning does not prevent lightning from striking; it gives a means for

controlling it and preventing deterioration by providing a low impedance path for discharge lightning energy discharge[24].

2.2.1 Lightning Generation

A thunderstorms generate lightning because of the electrical charges created in the clouds. The clouds become electrically charged due to static electricity that developed when the water molecules are rebound around inside the cloud. The accumulation of water droplet or ices crystals in the sky form a cloud. It has a positive charge at the top while a negative charge at the bottom. The increase of stronger updraft winds, results more lightning. The negative electrical charge builds up at the base of the cloud and a positive charge builds up on the ground. Since positive and negative charges attract they meet to form a bolt of lightning[3] as shown in Fig.2.3.

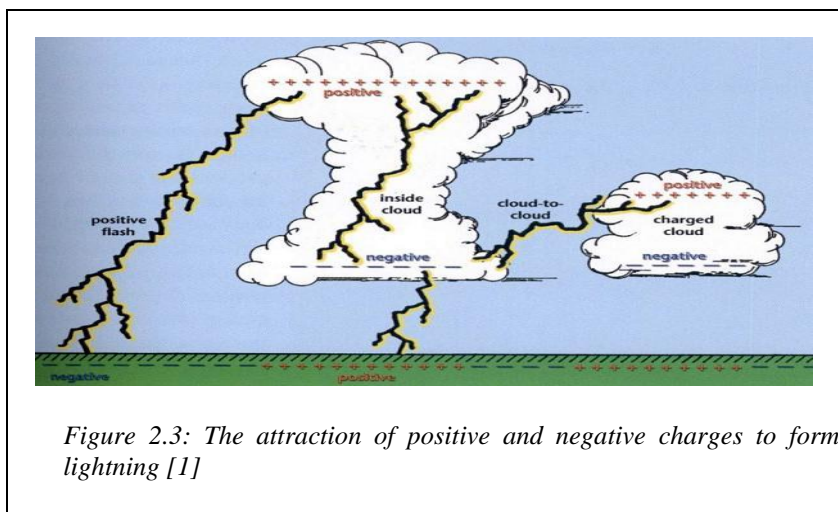

In the generation of lightning, we shall consider charge separation, leader formation, discharge and return stroke. The first step of lightning generation is the polarization where charge separation of water droplets or ice crystals floating in the sky made in the cloud and electrostatic induction in which the ground is induced with a big amount of positive[25].

The cloud charges negative at the bottom forces the negative charges in the ground to be pushed away from the area so that the ground leaves as positive charge.

The surface of negative charge creates close to the base of the cloud, it induces the surface of positive charge at the ground with an opposite sign charges attract each other. The voltage is created between the negative charges at the bottom of the cloud and the positive charges at the ground. When the voltage or potential difference reaches a high strength, the atmosphere tried to

minimize it. The first a stepped leader is created at the bottom of the cloud. By the definition, a stepped leader is a conduit at which electrons in the cloud can move to the earth (ground). The stepped leader travelled downward in steps several tens of meters in length and it has a pulse current of at least 1 kA in amplitude. Once this leader is closer to the ground, the potential to ground can be increased up to 100 MV before the attachment process with one of the upward streamers is completed[3].

When the stepped leader arrives near to the ground, a positively charged traveling spark is initiating on the same taller objects on the ground and the traveling spark goes upward and finally linked with the stepped leader. When the stepped leader and the back-stroke (return stroke) have connected, electrons from the cloud can flow to the ground, and positive charges can flow from the ground to the cloud. The flow of current from the cloud to the ground is visible light in the term as a return stroke. The return stroke has a velocity around one-third of the speed of light [3]. Average peak current value associated to the return stroke is monitored to be 30 kA, with increase time and time to half values around 5 and 75 μ s, respectively and associated with transferred charge of 5C lowered to the ground through the stepped leader referring to Pritindra 2006. After the first discharge, it is possible for another leader to spread down the conduit created by the former stepped leader. This new leader is called a dart leader that created from the top of the conduit lowering charges of 1Coulomb, until to follow the same channel of the first stroke and it travel downward at velocities of $3 \cdot 10^6$ m/s. Finally, a subsequent return stroke spreads upward from the ground to the cloud for three to five strokes lightning followed by the first stroke. Fig.2.4 shows the process of lightning generation.

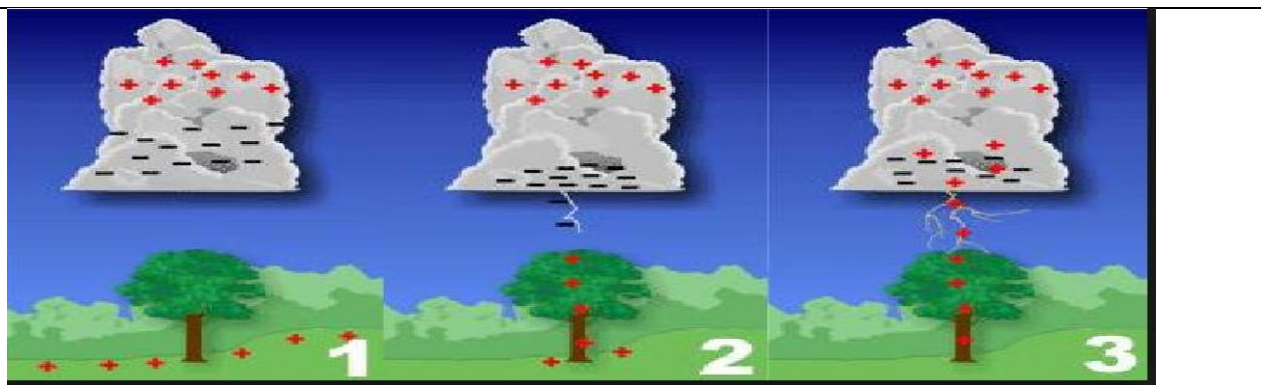

Figure 2.4: Lightning generation shows 1) Cloud and ground charges, 2) Charge separation and stepped leader formation, 3) Return stroke in terms of lightning flash [28]

2.2.2 Types of lightning discharge

There are two main types of lightning Cloud-to-ground and Cloud discharges lightning

i. Cloud-to-Ground Lightning

The cloud-to-ground (CG) lightning discharge Fig.2.5 process is a very important issue in the lightning research field because of the damage it can cause to human lives and the devices [29]. Cloud-to-ground lightning is the most dangerous form of lightning and its discharges are the ones that are responsible for serious lightning deterioration relative to the thermal and electromagnetic induction effects, like forest fires buildings burned, through electric wires and electronic equipment malfunction or failure [29]. The cloud-to-ground strokes with negative polarity count more than 90% but it can change according to regional and seasonal variations [30, 31]. While there is a small percentage of ground flashes that carry positive charge to the earth about less than 10% with 5% of the positive strokes exceed 250 kA and varies relative to seasonally with more frequent in the winter. [30, 31]. According to [29], positive lightning breakdowns are almost undetectable by the very high frequency radiation location system because of their weak very high frequency radiation.

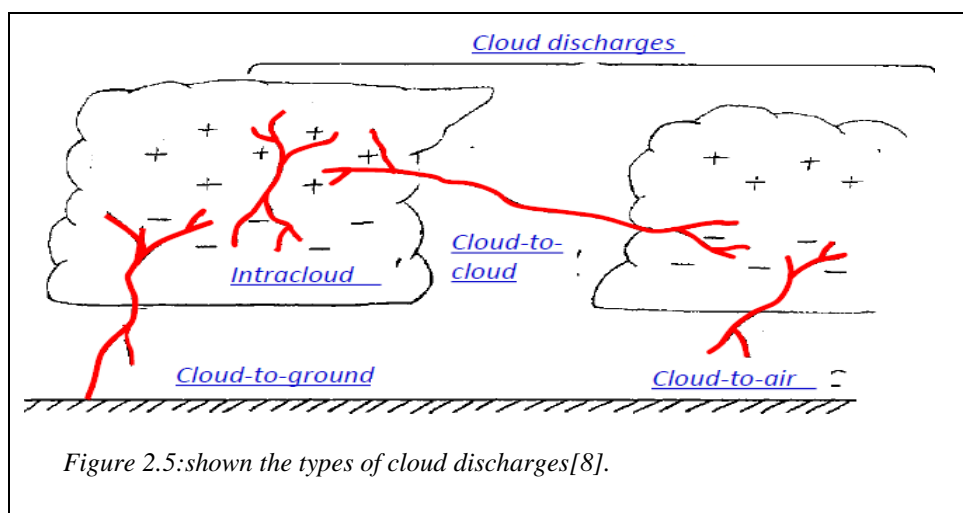

The lightning flashes are also more frequent occur during the winter season months than in the summer season months in some countries. This is possibly because the cold winter air does not create as many updrafts to lift the smaller positively charged particles to the top of the cloud. The way for lightning is to create a net path of transferring positive charges to the earth once there is a tall earth grounded object.

ii. Cloud discharges lightning

This discharge is divided into three types of lightning which are (i) intra-cloud discharges, those occurring within the confines of a thundercloud, (ii) inter-cloud discharges, those happened between thunderclouds, and (iii) cloud to air discharges, those occurring between a thundercloud and clear air. It is thought that the great number of cloud discharges occurring are of the intra-cloud type [10, 29]. Usually the abbreviation IC (for intra-cloud flash) is utilized to refer to all cloud flashes. Intra-cloud (IC) lightning remains in the cloud Fig.2.5 and is the most common type of discharge [10, 29]. The difference in detection efficiency between IC and CG discharges is thought to be predominantly caused by the fact that CG return strokes are generally more powerful than IC discharges and more easily detected at long ranges [11].

2.2.3 Lightning and Thunderstorms in Norway

The most reliable weather information can always be obtained from the local weather stations, which record weather data including date, temperature, weather phenomenon, snow/ice, precipitation, pressure, and wind on a daily basis. The influence of lightning varies according to the climatology of the thunderstorms for a particular area with respect to the country. The lightning is frequently available during the thunderstorm where there is heavy rain, strong wind and sometimes with snow and hail for some countries. The influence of lightning varies according to the climatology of the thunderstorms for a particular area with respect to the country. The Arrival Time Differing NETWORK (ATDnet, 2014) lightning detection in the range of year 2008-2012 shown the quantity of monthly variations of lightning in the European Continental Fig.2.6 The ATDnet in the January and February, lightning occurrence throughout Europe is at a minimum in winter due to the lack of solar heating and available atmospheric water vapour reduce the amount of energy available for storms to develop. General lightning activity over continental Europe is very low. In the March seen that the early signs of the resurgence of convection from solar heating where Northern regions of Europe such as the UK and Scandinavia a little change in lightning between February and March. In the April up to July the distribution of lightning across Europe increase with the greatest flash densities occurring over land but more increasing of lightning in Norway in May and with storm in June. In July is where lightning densities across Europe peak during July with the highest density averaging almost 4 lightning flashes per km² during the month and Flash rates average nearly 100 000 flashes per day for Fig.2.7. by contrary

in March where had the lowest lightning flash of all 12 months. In August and September, lightning densities begin to drop across Europe as the air temperatures reach their peak and solar heating decreases, generating less instability. In October and November, lightning densities across all land regions became low. Finally, in December is the winter time where lightning is at minimum[11].

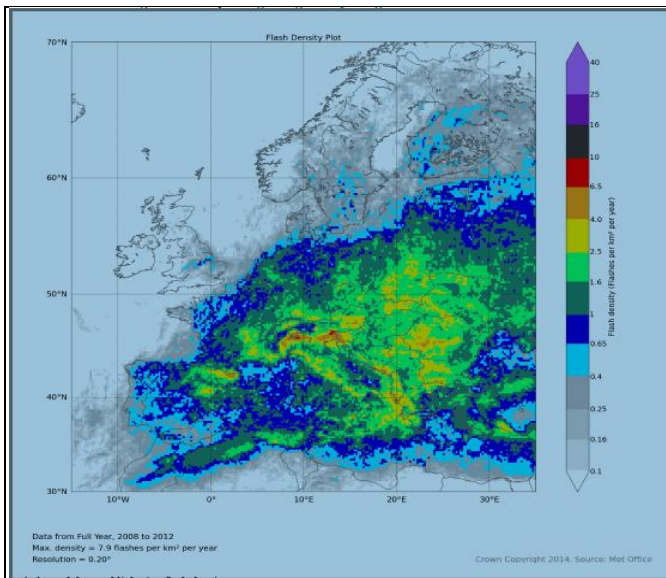

Figure 2.6. ATDnet lightning data 2008-2012 for Europe(all 12 Months) [11].

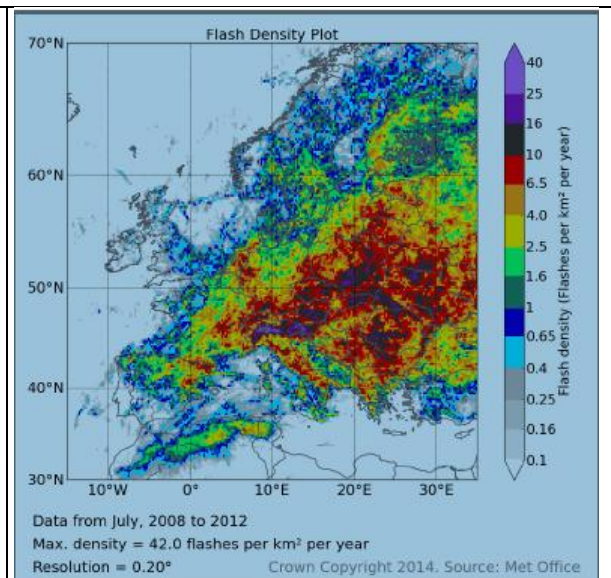

Figure 2.7. ATDnet lightning data 2008-2012 for Europe(only in July) [11]

The high flash density cause power line are outages i.e. flash density increase with the numbers heard thunder per day or per hour. In summary, the design and protections of power line according to the climatology is the best way for reducing the impact caused by thunderstoms.

The stronger the stroke cause more harmful of the power line. Norway as the one of the country with ice storm, although icing has also to be a big impact an overhead power lines. It is truly a rare event, and it is appropriate to regard icing as a special event. Ice storm are very profilic producers of power flashes and widespread outages. The weight of ice can bring down electric lines and poles directly as shown in Fig.2.8[32].



Figure 2.8. Photo taken from you tube

2.2.4 Main Parameters in Lightning strike

Lightning parameters are standardized for the goal of assessment of lightning performance of specific power line or apparatus designs and for improvement design and protection of electric power systems, As though lightning caused outages and equipment deterioration during thunderstorms, stand for leading the causes of failures in the electric utility industry[3, 30, 31, 33, 34]. The main parameters for the assessment of lightning protection operation of power transmission and distribution lines or for evaluation of different protection methods are lightning current and ground flash density[35]. The value lightning parameters should be classified according to geographical regionally and seasonally i.e. each location has own lightning parameters measured by metrology using a Triangulate the Emitted Radio wave identification algorithm able of detecting and locating individual ground contact points from flash and stroke data[30, 31].

1. Ground Flash Density

The lightning ground flash density (N_g), is defined as the number of cloud-to-ground flashes occurs in the year per kilometer square, it is a significant meteorological data, which is, utilizes in monitoring and calculation of lightning strikes hazard of a system or structure. Generally, Ground Flash Density is a proportion of lightning hits number to the ground, over duration of one year, averaged by the countries landmass per km^2 . It is known that about 25 % of lightning hitting happen are cloud-to-ground (CG). The ground flash density has been estimated priory from records of lightning flash counters (LFC) in many nations and, more nowadays, from records of lightning location systems in different countries [36, 37]. The lightning flash counter (LFC) is an antenna integrated with apparatus that provides a logging system, once the electric or magnetic

field generated by lightning strike happen, LFC records data like number of lightning event and time sequence at the determined place. Every LFC can record both ground and cloud lightning discharges, but only ground discharges are necessary for the assessment of ground flash density (N_g). The range of flash signal frequency varies from 100Hz to 10KHz, after being filtered by the frequency centers. The first lightning detector antenna has been developed, and used in activity so-called grozootmetchik by Popov a Russian Scientist in 1896 year[38].

Since 1970s, Lightning Location System (LLS) based on the magnetic field and time difference location theory has been established. Ground-based LLS is composed by a set of four to five sensors and a central processor unit. Every sensor measures the electromagnetic signal generated by a lightning discharge and dispatch back information about the associated waveform characteristics to the central processor. An LLS sensor may operate at frequencies varying from Extremely Low Frequency (ELF) to Ultra high frequency (UHF)[39]. LLS have contributed a significant effort in localization of lightning strike precisely. Lightning location system may measure the number of lightning strike and back strike, ground flash time and location, amplitude and polarity of lightning current with time difference and magnetic field direction technique [34] [3, 33, 40]. The main role of N_g in Lightning Protection is to calculate risk assessment, in designing electrical and telecommunications equipments. Anderson[41] and McGorman[42] have developed the equations for calculating the ground flashes density based on Thunderstorm-days or Thunderstorm-Hour (TH) data. Ground flash density is calculated by these equations:

$$N_g = 0.04TD^{1.25} \text{flashes} / \text{km}^2 / \text{year} \text{ or } N_g = 0.04TH^{1.1} \text{flashes} / \text{km}^2 / \text{year} \quad (2.1)$$

Where TD is thunder days or keraunic level which is the average number of days per year the thunder can be heard and TH is thunder hours which is the average number of hours per year the thunder can be heard.

For the lightning protection standard, the ground strike-point density N_{sg} is the main parameter we shall consider. The choice of the ground strike-point density, N_{sg} parameter is due to the hazard evaluation of a determined building or structure, applicable to the international and national lightning protection standards[33, 34]. This lightning strike-point density is more useful than the lightning ground flash density when we consider the lightning protection of a structure building. To cover this effect, the value of N_g should be multiplied by 2 while in the countries where the LLS (Lightning Location system) systems will directly give the ground strike-point density such a factor 2 will not be regarded [33, 34]. The estimation average, or, maximum, better

in critical structures value of N_g on the ground flash density map of the region implies on the condition that these values were confirmed during a recent period covering at least 10 years in a circular surface of at least 5 km radius around the structure or building to be monitored, and, when estimating the lightning hazard assessment, multiply this number by a factor of 2 [33, 34], i.e.

$$N_{sg} = fN_g \quad (2.2)$$

Where, f is a proposed factor which is equal to 2.

In high risk level and in larger region the maximum value may be utilized instead of the mean value.

In many countries where no LFC (lightning flash counters) or LLS are installed nor map of N_g is available[33, 34]. The lightning protection national standards is:

$$N_g = 0.1T_d \quad (2.3)$$

In regions without ground based lightning location systems or lightning flash counters, the recommended evaluate of ground flash density is[33, 34, 43]:

$$N_g = \frac{1}{3}N_t \quad (2.4)$$

Where, N_t is the total (CG + CC) density of optical flashes per km² per year.

“Power lines can failures even if GFD levels are low when they pass through high-resistivity soils like deserts or when lines span across hills or mountains, where ground wire or lightning arrester earthing becomes difficult”[3].

2. Lightning current

The current is the primary source for thermal and mechanical damages caused by lightning stroke. Besides that, the rate of increase of the lightning currents may induce overvoltage in electrical and electronics devices[44]. The most important current parameters are those related to the lightning damages and also the parameters needed for designing lightning protection which are: current peak I_p (kA), electric charge ($Q = \int idt$) in Coulomb, specific energy ($\frac{W}{R} = \int i^2 dt$) in joule and maximum current derivative $(\frac{di}{dt})_{max}$ [45, 46].

The above current parameters are described by[44]:

i. **Specific energy** assumes the responsibility of mechanical forces and for heating effect when lightning current passing through metallic conductors. If the energy in a lightning flash exceeds the thermal limit of the struck, it may be an outage or permanently damage. The material

protection should be design based to the assessment lightning energy generated in the recently years.

ii. **Electric charge** is responsible for the melting effects at the attachment of the lightning channel.

iii. **Maximum current derivative** determines the maximum of magnetically induced voltages into open loop.

iv. The return-stroke speed will affect the component of the voltage which is produced by the induction field of the lightning stroke

v. **Peak current**

The peak current value is important parameter for design the earthing termination system. This peak current determine the maximum value of the voltage drop caused by a lightning current enters following through the earthing resistance[44]. The maximum voltage drop caused by direct strike is determined by using Ohm's Law, is given by:

$$V = I_p \cdot R \quad (2.5)$$

where I_p : the lightning stroke current, R is the earthing resistance.

The voltage drop due to strike the air termination of the building or the surrounding area is given by[47]:

$$U = \frac{\mu_o}{4\pi} \frac{di}{dt} 2a \ln \frac{b}{b_o} \quad (2.6)$$

Where a is the height of the line, b_o is the distance between the line and the lightning strike and b : the sum of b_o and the length of the line. "The earth termination of a LPS (Lightning Protection System) must be able to disperse lightning current into the ground without evoking any danger to people or damage to installation inside the protected structure .The high peak current value should be considered when dealing with the dispersion of the lightning current into the ground by minimizing any potentially dangerous over voltages and the transient behavior of earthed electrodes under impulse current[48].

The available data of the lightning currents are almost the same as current peak value [44]. The produced voltage is a function of the peak current for direct and indirect strokes[30].The first strokes are associated with a peak current by a factor around 2 to 3 times larger than following strokes[3]. Nevertheless, in one out of three cloud-to-ground flashes contain at least one subsequent stroke with maximum electric field. Then, the peak current values is greater than the

first-stroke peak [46]. The peak current (I_p) written in relation with electric field peak (E_{peak}) is as follow:

$$I_p = -\frac{2\pi\epsilon_0 c^2}{v} E_{peak} \text{ and } E_{peak} = cB_{peak} \tag{2.7}$$

Where c is the velocity of light in free space, D is the distance of the stroke from an object, v is the velocity of the return stroke, and B_{peak} is the peak magnetic induction[30].

The variations lightning Peak Current available according to CIGRE (Conseil International des Grands Réseaux Électriques) distribution are, 98% of peak currents exceed 4 kA, 80% exceed 20 kA, and 5% exceed 90 kA and for the IEEE the probability distribution of first negative return stroke current to exceed values in per unit [8, 30, 43], it is obtained as the difference between the probability for current to be equal or greater than the lower limit and the probability for current to reach or exceed the higher limit as written below:

$$P(I_p \geq i_o) = \frac{1}{1+(\frac{i_o}{31})^{2.6}} \tag{2.8}$$

Where $P(I_p \geq i_o)$ is the probability that the negative first return stroke has a peak current I_p that exceeds i_o ; i_o is the prospective first return stroke peak current (kA) and 31kA is the median value of the first negative return stroke peak current which was proposed with respect to the overhead power line with 20kA of the critical current of flashover[30].

The log-normal distribution of subsequent negative return stroke current value [30, 43] is given by:

$$P(I_p \geq i_o) = \frac{1}{1+(\frac{i_o}{12})^{2.7}} \tag{2.9}$$

Where $P(I_p \geq i_o)$ is the probability that a subsequent return stroke has a peak current I_o that exceeds i_o , i_o is the prospective subsequent return stroke peak current (kA) and the median value of the subsequent return stroke peak current is 12kA

The Fig2.9 shows the probability distribution of the first and subsequent negative return stroke current from (2.8) & (2.9) where $I_p(kA)$ is the peak value which is in the range of 1–200 Ka, with an interval of 1kA [49] and the probability that the first negative return stroke is applied to values of I_p up to 200 kA and the median (50%) peak current value is equal to 31 kA [8].

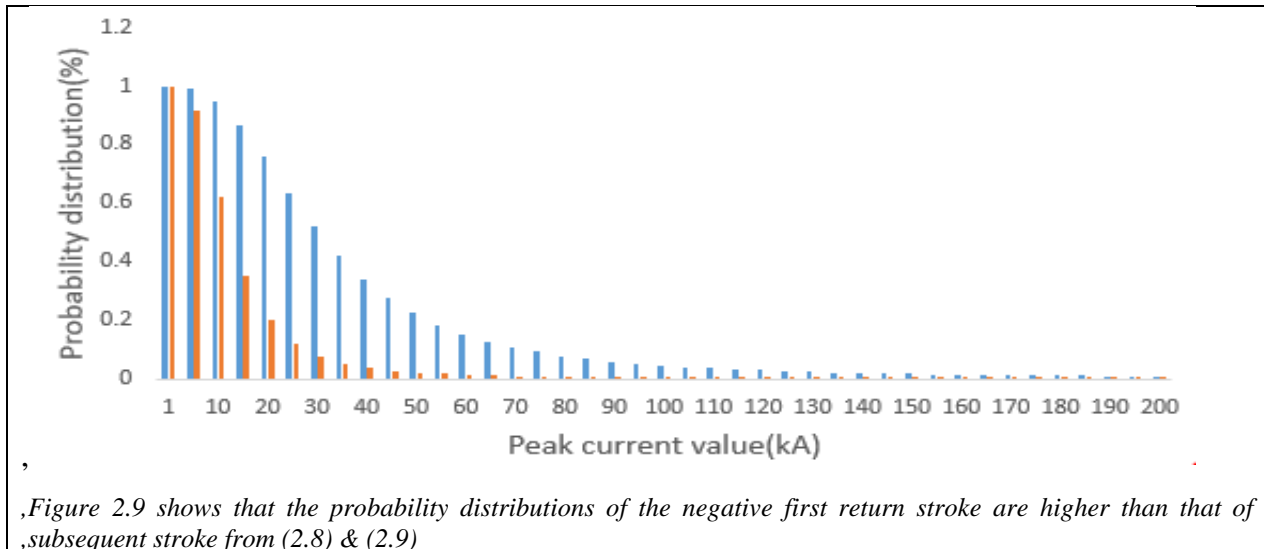

,Figure 2.9 shows that the probability distributions of the negative first return stroke are higher than that of ,subsequent stroke from (2.8) & (2.9)

The negative and positive return stroke current are almost similar but the maximum value of positive return stroke currents are higher than that of the first return negative stroke current [30, 31],.

Note that, the shielding failures are caused by flashes with low first return stroke currents relative to the small striking distance [30, 31]. In order to maximize protection causes by effect of lightning strike, the lightning parameters may be design relating to the maximum probability of insulation flashover and heating effects.

2.3 The different types of lightning current strike to the power line

There are three types of lightning current: positive, first negative and subsequent lightning current. These three types had the impact in power line which could destroy the transformers.

The negative return stroke currents had more distributions than the positive lightning current stroke. According to [10],[30, 31], in their research found that the positive return stroke currents are less than 10% while for that the first negative return stroke currents are more than 90%. The positive stroke has more impact to the power line because it has longer duration waves and higher delivered charge than that of negative stroke which cause more thermal damage. The energy delivered by the positive stroke exceed the capability of insulator to withstand thermal capability of surge arrester due to the longer duration wave and higher delivered charge which cause transformers failures or damages [31]. The values of positive return stroke current are shown Table 2.1 and the log normal distribution of the first negative as well as subsequent return stroke current from Fig2.9. The positive return stroke current has 5% exceed 250 kA Table 2.1 which

corresponding 95kA magnitude of the first negative stroke and 35kA magnitude of the subsequent return stroke current Fig2.9.

Table 2.1 for positive lightning current parameters [10]

Parameters	Units	Sample size	Percent exceeding tabulated value		
			95%	50%	5%
Peak current (minimum 2 kA)	kA	26	4.6	35	250
Charge (total charge)	C	26	20	80	350
Impulse charge (excluding continuing current)	C	25	2.0	16	150
Front duration (2 kA to peak)	μs	19	3.5	22	200
Maximum dI/dt	$\text{kA } \mu\text{s}^{-1}$	21	0.20	2.4	32
Stroke duration (2 kA to half-peak value on the tail)	μs	16	25	230	2000
Action integral ($\int I^2 dt$)	A^2s	26	2.5×10^4	6.5×10^5	1.5×10^7
Flash duration	ms	24	14	85	500

The measured maximum value of positive stroke is 300kA with charge transfer about 100C or more while for negative return stroke few percentage about 20% exceed 100kA[10].

The negative first return strokes current produce less stress on power line insulation while a subsequent negative strokes have lower peak current but with the shorter wave fronts which could stress the system insulation more in the case of low footing resistances and tall objects [31].

The charge transfer of the negative return stroke is about four larger total charge than the negative subsequent strokes i.e. three to four times higher current maximum steepness and the median of return stroke current peak for first negative return strokes is two to three times higher than that for subsequent strokes. The maximum positive and negative return stroke current measured in 14 summer months using NLDN (National Lightning Detection Network) from 1991–1995 were 957 and 580 kA respectively and the negative subsequent strokes with peak currents not exceeding 60 kA[10]. The higher magnitude lightning current stroke to the power line, it had few probabilities to resist in case of striking due to the higher energy transferred and it could resist when a power line insulations as well as equipments have 90% BIL levels and with standard protections. Fig2.10 show the cummulative statistical distributions for positive, first negative and subsequent return stroke lightning current at tower top.

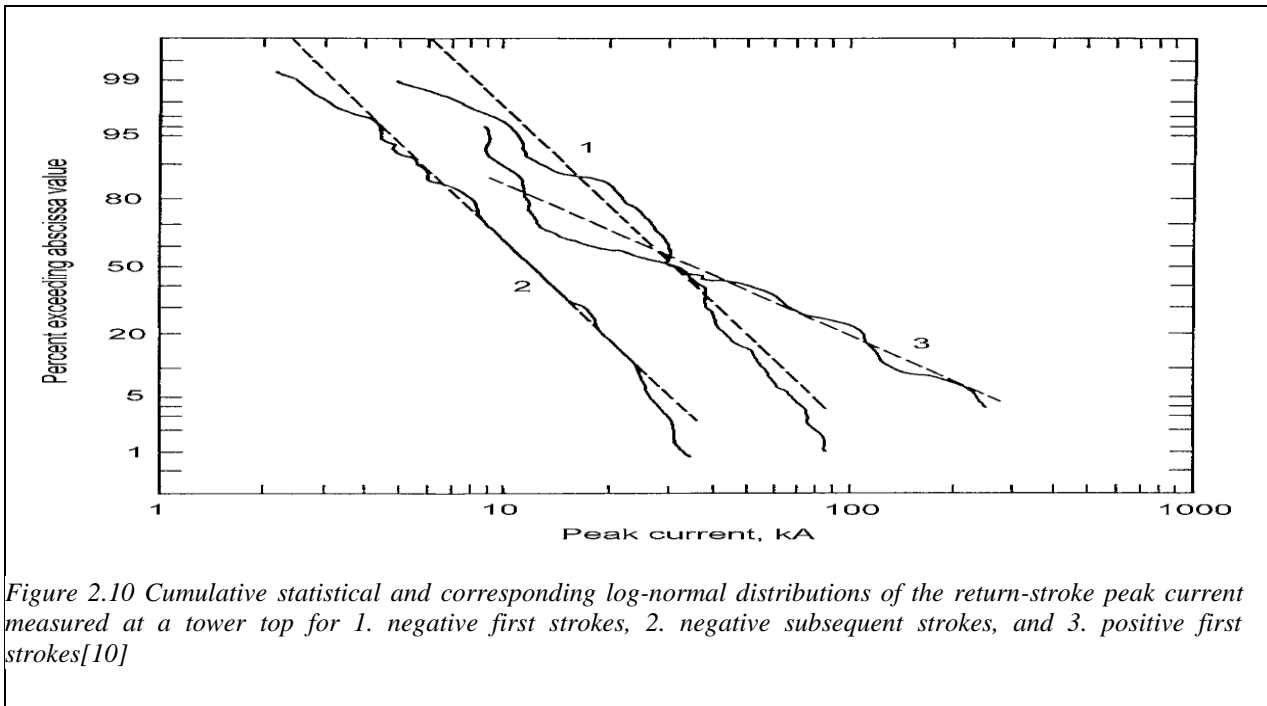

Figure 2.10 Cumulative statistical and corresponding log-normal distributions of the return-stroke peak current measured at a tower top for 1. negative first strokes, 2. negative subsequent strokes, and 3. positive first strokes[10]

Note: The transformers protections of the Haugaland Kraft power line distributions networks could refer to the data from Norwegian Meteorological Institute showing how the incidence of lightning current in the early years in that region and the NVE report, 2014 [11] showing that how the incidence lightning will increase in the future years as it demonstrated that it will increase 25% in 2050 with uncertainty value increase up to 30% and further increase between 0 up to 50% for 2100. In order to maximize Haugaland Kraft transformers protections, the constructions, the equipments design and the protections of the power line should base on the above information for preventing lightning transient disturbances.

2.3.1 Effect of lightning in Power Line

There are two effects generated by transient disturbances from the lightning strike

1. Direct stroke and
2. Indirect stroke

A lightning is a major cause interruptions of a power line. It can cause an overvoltage when there is a striking to the phase conductor or tower or shield wire or an object near by a power line. These overvoltages can cause an outage or damage a power line equipments [4]. The use of higher insulations level and protection against lightning with the equipments designed with respect to the standard level by considering long term environment variations are recommended to keep a power line safely. These two effects are described below.

1. Direct strike

A direct stroke occurs if a lightning strike either to the tower or the shield wire or the phase conductor Fig.2.11 [3, 5]. Most of the time, direct lightning strike the phase conductors [50]. These phase conductors are usually connected to the distribution transformers from where the electricity is distributed to the consumers and if the lightning currents are not well properly diverted to the ground before entering to the transformer, it can cause damage the transformer windings, which is very expensive and difficult to repair. In additional, the lightning current could be transferred to the consumer side after passing through the transformer, causing problems in the electronics at the consumer's end [4]. The direct lightning will be permanently damaged to the power line, if the injected lightning energy exceed the handling capability of power line. When lightning strikes direct to tower, there will affect to increase of the tower potential dependent on the value tower footing resistance and the overhead line insulation levels [51] and “ the traveling voltage will be generated which travels back and forth along the tower, being reflected at the tower footing and at the tower top, thus raising the voltages due to electromagnetic coupling at the cross-arms and stressing the insulators”[50]. The insulator will cause back flash if the transient voltage exceeds its withstand capability. “When a lightning strikes a shield wire, the generated traveling voltage wave will travel to the nearest tower, produce multiple reflections along the tower, causing back flash across an insulator lines”[3, 50]. The number of direct flashes to a power line is given by equation (2.10) [18], [40].

$$N = Ng(d + 28h^{0.6})(1 - S_f)10^{-6} \text{Strokes/km year} \quad (2.10)$$

Where, N : the number of direct flashes to a power line, Ng : Ground Flash Density or number of stroke per Km^2/year ; h : height above the ground which is similar to the tower height, S_f Shielding factor due to nearby objects and d : the distance between the outer most 2 conductors.

Most overhead power lines are equipped with a shield wires to prevent the direct strike to the phase conductors and there is a shielding failures when lightning strikes a phase conductor.

The analysis of direct strokes to overhead lines can be divided into two classes [5]:

- i) Unshielded lines and ii) shielded lines

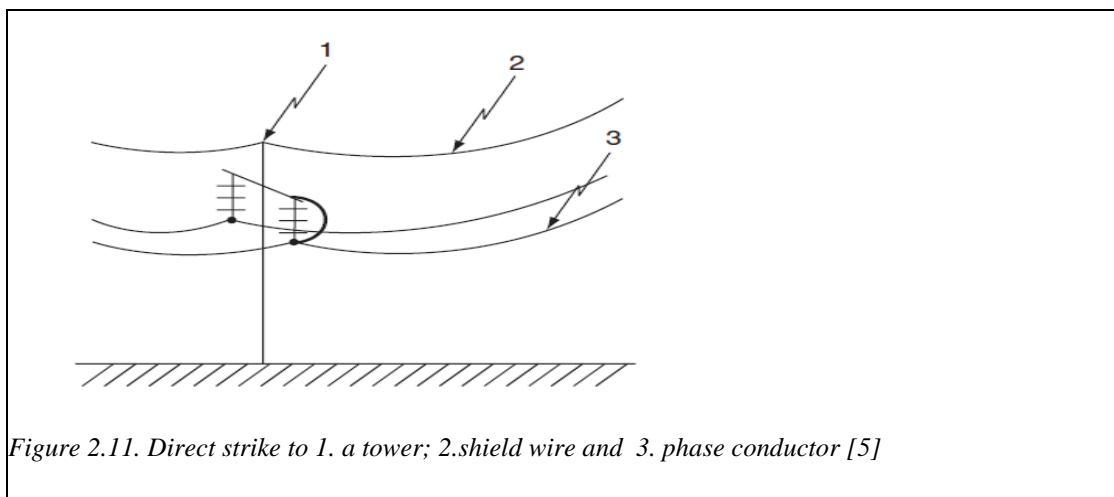

i) Direct Strokes to Unshielded Lines

1. When lightning strike one of the phase conductors for unshielded power line, the return-stroke current will split into two equal halves giving rise the voltage waves that propagate in the opposite directions along the striking point Fig.2.12[4] [3, 5].

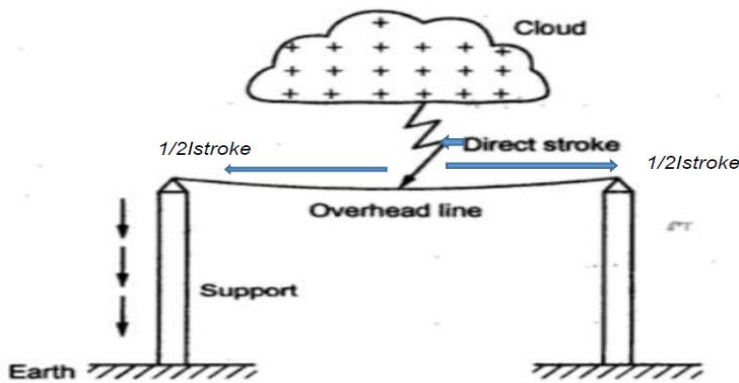

Figure 2.12. unshielded direct lightning on phase conductor [7]

The lightning current path or discharge come from the cloud directly to the overhead phase conductor. The cloud will induce the opposite charges an overhead power line directly to the phase conductor. When the potential difference between the cloud and overhead lines become more than breakdown strength of Air, the lightning discharge will take places between cloud and phase conductor. The traveling voltage waves stress the insulator strings from which the phase conductors are suspended. These waves can produce the excessive stress in which it can reach to the substations and damage the apparatus [3, 5];[52],[53]. The traveling voltages is proportional to the return stroke current flow in each direction i.e. half of the stroke current and the characteristic surge impedance of the line or of the phase conductor which is given by:

$$V(t) = \frac{Z_p I(t)}{2} \tag{2.11}$$

Where $Z_p/2$ is the charge on the conductor flows to both sides of the conductor in the form of travelling waves[53]; $Z_p = \sqrt{L/C}$, is the surge impedance of the line, L and C are the series inductance and capacitance to ground per meter length of the line[3, 5]; $I(t)$ is the lightning return stroke current in function of time [30, 54-57] and it was computed by equation (2.12).

$$I(t) = \frac{I_p}{\vartheta} \cdot \frac{(t/T_1)^n}{1+(t/T_1)^n} \cdot e^{-\frac{t}{T_2}} \tag{2.12}$$

$\vartheta = \exp[-(\frac{T_1}{T_2})(nT_2/T_1)^{1/n}]$, is the correction factor of the lightning current value; I_p is the peak value of the stroke current; T_1 and T_2 , is the front and tail time constant respectively. The value of T_1 , T_2 and ϑ were analyzed and computed Table2.2 according to IEC-62305-1,2010 [57].

Table 2.2 shown the values of T_1 , T_2 and ϑ with respect to the return stroke current in equation (2.12)

Parameters	First positive impulse			First negative impulse			Subsequent negative impulse		
	LPL			LPL			LPL		
	I	II	III-IV	I	II	III-IV	I	II	III-IV
I (kA)	200	150	100	100	75	50	50	37,5	25
k	0,93	0,93	0,93	0,986	0,986	0,986	0,993	0,993	0,993
T_1 (μ s)	19	19	19	1,82	1,82	1,82	0,454	0,454	0,454
T_2 (μ s)	485	485	485	285	285	285	143	143	143

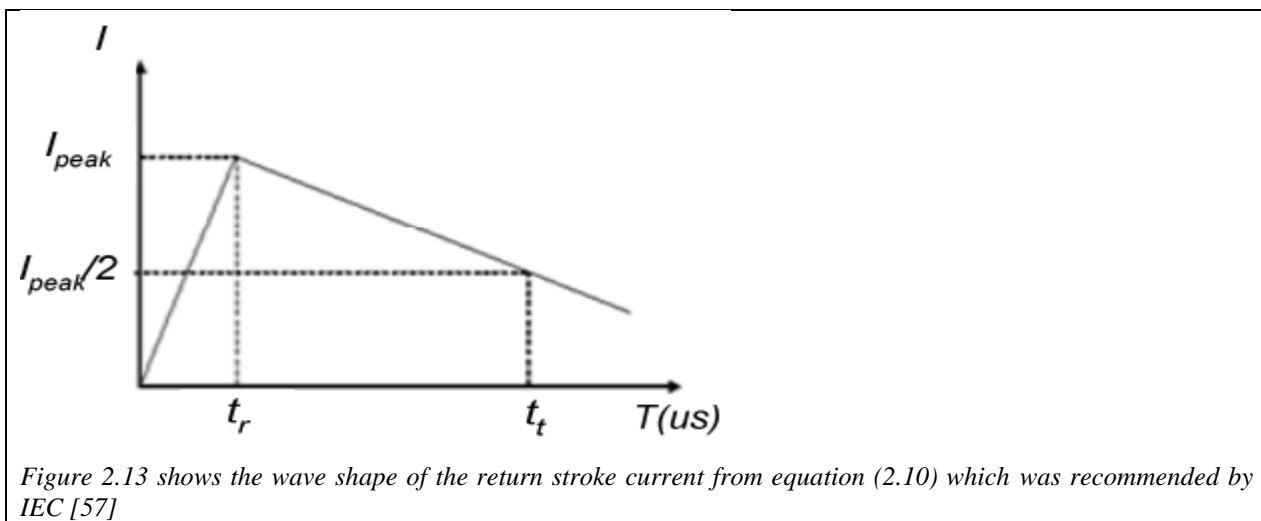

As the travelling wave voltage is proportional to the return stroke current, therefore, the overvoltage became higher depending on the lightning stroke. This overvoltage will stress the insulators and when the traveling wave voltages exceed the designed voltages BIL, there will be a flash over and it can cause an outage rate. The critical return stroke current value that can cause an insulator flashover of the line for the specified BIL is:

$$I_c = \frac{2BIL}{Z_p} \tag{2.13}$$

The flashover voltage or voltage withstand capability of the insulator is given by [58-60] equation (2.14).

$$V_{Fo}(t) = K_1 + \frac{K_2}{t^{0.75}} \tag{2.14}$$

Where $K_1 = 400.L$; $K_2 = 710.L$; L is the gap or insulator length in (m) and t is the time to flashover in (μ s) for 0.2 to 16 μ s.

The power line equipments will be designed with refer to the BIL (Basic Impulse Insulation Level) and critical flashover voltage (CFO or V_{50}). Therefore, the distribution power line insulators should design and installed with respect to the BIL level and long term future records of the geographical and environment for the region located the power line. According to [3, 5], a BIL is defined in two ways “as statistical BIL where the probability of insulation will withstand of 90% under specified conditions which has the crest value of a standard (1.2/50 μ s) lightning impulse voltage and it is also defined as the conventional BIL where the probability of insulation to withstand for a specific number of applications under specified conditions” and for CFO is defined as the insulation capability to withstand of 50% applications in case of lightning strike.

2. When lightning strike to the tower for unshielded power line, a current would be discharged through the metal work of the tower and there would be a potential difference between the top and bottom of the tower and the traveling current wave will travel along the tower and over the tower-footing resistance before being dissipated in the earth.

A tower is modelled as a vertical transmission line and its surge impedance is given by [61] :

$$Z_t = 60 \left\{ \ln \left(\frac{h_t}{R} \right) - 1 \right\} \text{ where } h_t, \text{ the height of tower \& } R \text{ a radius of a tower base. The voltage}$$

and current waves will travel along the tower with a velocity, v_t at time t which is vary from 0 up to 50 μ s and it is terminated by two parts: the lower end by tower-footing resistance, R_{tf} and upper end by lightning channel which have a transmission line channel surge impedance, z_{ch} Fig.2.14. The upper end is at the top of tower and the lower end at the bottom of tower.

In additional, the cross arms are attached to the tower which used to support insulators. The phase conductors will travel the tower passing through insulators without cause any short circuit by transmitting at a long distance. The lightning channel will be very close to the phase conductors when lightning strikes the tower in the power line. The travelling voltage wave due to direct stroke to the tower in power line will increase and given by [3, 5, 7]:

$$V_{ins} = L_T \frac{di}{dt} + R_{tf} i \quad (2.15)$$

where V_{ins} is the insulator voltage i.e. voltage between top of a tower and earth., L_T is the inductance of tower, R_{tf} is the tower footing resistance; i is the stroke current flowing through the tower and di/dt is the rate-of-rise of a stroke current (kA). If V_{ins} is more than BIL level, in that case the flash over occur between tower and line conductor and results in power line outages.

The traveling voltage and current waves will be repeatedly reflected at either end of the tower while producing voltage at the cross arm V_{ca} . This traveling waves could form in the both directions of conductor for reaching to substation equipments to cause their damage[3].

The insulators from which the phase conductor are suspended will then be stressed at one end by V_{ca} to ground and at the other end by the power frequency phase-to-ground voltage of the phase conductor. Neglecting the power-frequency voltage, the insulator voltage, V_{ins} , will be equal to the

cross-arm voltage, V_{ca} [3, 5] and it expressed as follow:

$$V_{ca}(t) = \sum_{n=1}^n (a_{r1} a_{r2})^{n-1} V_{to}(t - (2n-1)T_t + T_{ca}) u(t - (2n-1)T_t + T_{ca}) +$$

$$ar1n=1n(ar1ar2)n-1Vtot-2n-1Tt-Tcaut-2n-1Tt-Tca \quad (2.16)$$

Where, the initial voltage traveling down the tower is $V_{to}(t) = Z_t I(t)$.

According to Chowdhuri and Yan,2002 [16], the initial tower current in function of time t is calculated by:

$$I(t) = \alpha_1 t u(t) - \alpha_2 (t - t_f) u(t - t_f) \quad (2.17)$$

where, $\alpha_1 = \frac{I_p}{t_f}$; $\alpha_2 = \frac{(2t_h - t_f)I_p}{2t_f(t_h - t_f)}$; I_p = peak return stroke current; t_f = front time i.e. the interval

between the beginning and peak of the waveform which is varies from 0.5 up to 10 μ s;

t_h = time to half value is defined as the time interval between the origin and the instant on the tail when the voltage has decreased to half of the peak value; $u(t)$ is the shifted unit step function.

The voltage reflection coefficients at the two ends of the tower are given by: $a_{r1} = \frac{R_{tf} - Z_t}{R_{tf} + Z_t}$ and

$a_{r2} = \frac{Z_{ch} - Z_t}{Z_{ch} + Z_t}$; $T_t = \frac{h_t}{v_t}$, the time of travel from the tower top to its foot and $T_{ca} = \frac{h_{ca}}{v_t}$, the time

of travel from the cross arm to the tower foot; $v_t = \frac{c}{\sqrt{1 + \frac{500}{I_p}}}$ return stroke velocity; velocity of

light at free space $c = 3.10^8 m/s$ and n= number of reflected wave point.

Fig.2.14 shown how the waves travelling in case of lightning strike to the tower top for unshielded power line [3]

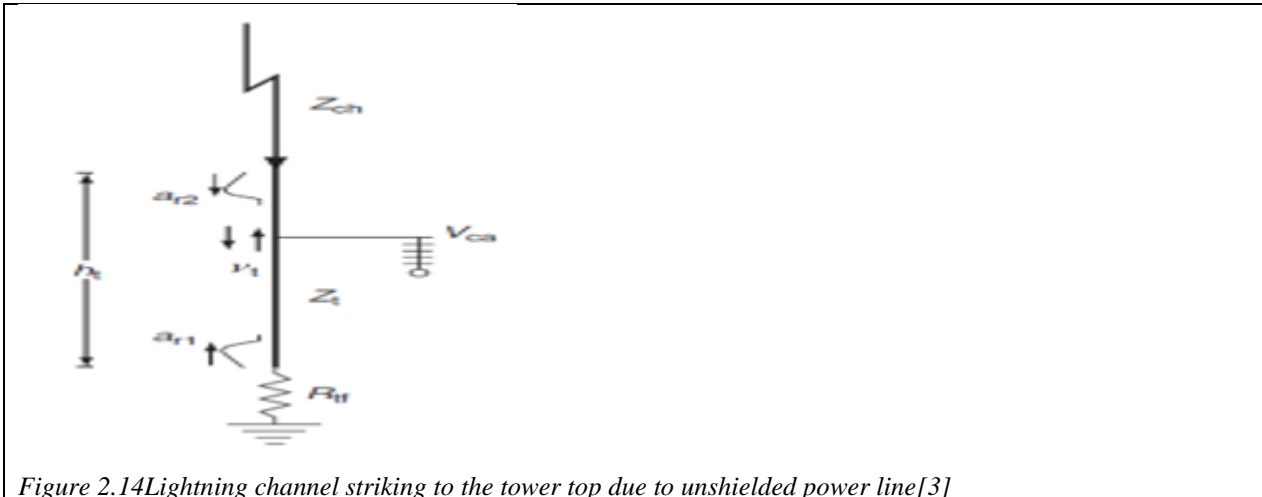

i) Direct Strikes to shield Lines

Power lines are protected from direct strikes to phase conductors by installing a ground wire above the phase conductors. The overhead ground wire is also called air termination or shield wire which is installed above of the phase conductors and it plays an important role for protecting power lines when it strikes by direct lightning. The ground wire will accumulate the lightning currents or discharges and then directly divert to the ground[4]. For a shielded line, lightning strike the phase conductor or the shield wire or the tower.

1. If the lightning strikes an overhead ground wire (shield wire) at mid span, the lightning current injected into the ground wire will divide into two equal halves parts and travel at the both opposite directions of the ground wire from a striking point Fig.2.15[53].

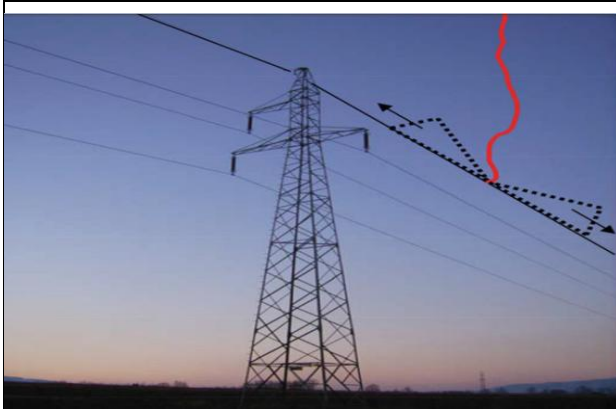

Figure 2.15. Traveling wave due to lightning strikes a shield wire [4]



Figure 2.16. The current passes along the tower to the ground [4]

The ground wire(s) grounded at the tower and the return stroke currents flow to the ground (earth) travel through along the tower. The lightning strike will increase the voltage at the tower foot which result for rising voltage between the tower and the phase conductors. If this voltage is greater than the critical value necessary to cause an electrical breakdown across the insulators, then, there will be a spark at the ground wire and at one of the phase conductors [4] Fig.2.16. The generated spark will cause the return stroke to flow into the phase conductor. The creation of spark between ground wire and phase conductor will bring large voltage between phase conductor and ground wire. The spark has a small resistance, which causes lightning current to flow into the phase conductor, which bring the fault in power line. This fault will be eliminated or clear when cut off a line and the power will reconnect after stopping the flow of current cause that spark [4]. The voltage flow to the tower foot should decrease by reducing at very low tower footing resistance to enable the lightning charge to quickly discharged to the earth [3].

1. When lightning strikes to tower for a shielded power line, as the shield wire is directly attached at the point of the towers top, then, the return-stroke currents are directed to ground through the tower-footing resistances. The travelling waves will be reflected between tower top and tower foot thereafter they transmitted to the tower. The return stroke current I_p will divide into three parts Fig.2.17. The first part is the return stroke current flow through along the tower to the ground, I_T , and the remaining of the return stroke current will divide into two equal halves parts i.e. $\frac{1}{2}I_g$, following both opposite directions along the ground wire and pass through to the closest tower.

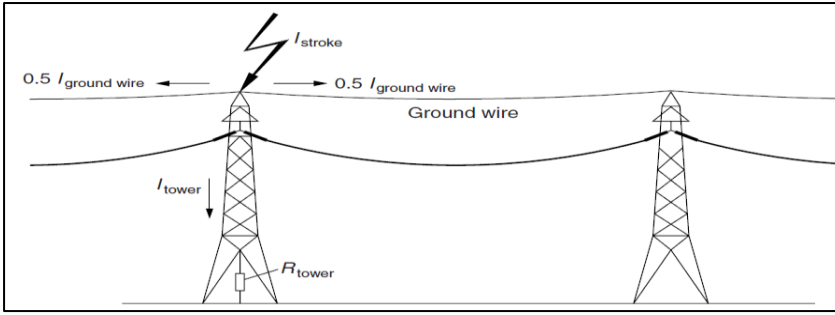

Figure 2.17: Stroke current due to lightning strikes to a tower top [3, 15, 16]

The voltage could stress insulator in case of direct stroke to tower for a shielded power line is given by[3, 15, 16]:

$$V_{ins} = V_{ca} - k_{sp} \cdot V_T \tag{2.18}$$

where V_T : the shield-wire voltage, which is the same as the tower-top voltage and is given by:

$$V_T(t) = V_{to}u(t) + a_{t2}a_{r1} \sum_{n=1}^{\infty} (a_{r1}a_{r2})^{n-1} V_{to}(t - 2nT_t) - T_{ca}u(t - 2nT_t) \tag{2.19}$$

The cross arm voltage $V_{ca}(t)$ at which insulator is suspended given by:

$$V_{ca}(t) = \sum_{n=1}^{\infty} (a_{r1}a_{r2})^{n-1} V_{to}(t - (2n - 1)T_t + T_{ca})u(t - (2n - 1)T_t + T_{ca}) + a_{r1} \sum_{n=1}^{\infty} (a_{r1}a_{r2})^{n-1} V_{to}(t - 2nT_t - T_{ca})u(t - 2nT_t - T_{ca}) \tag{2.20}$$

$k_{sp} = \frac{Z_{Pg}}{Z_g}$, is an electromagnetic coupling with shield wire which it has an advantages to reduce

$$\frac{(0.5Z_gZ_{ch} / (0.5Z_g + Z_{ch}) - Z_t)}{(0.5Z_gZ_{ch} / (0.5Z_g + Z_{ch}) + Z_t)}$$

insulator voltage; $a_{r2} = \frac{(0.5Z_gZ_{ch} / (0.5Z_g + Z_{ch}) - Z_t)}{(0.5Z_gZ_{ch} / (0.5Z_g + Z_{ch}) + Z_t)}$ and $a_{r1} = \frac{R_{ft} - Z_t}{R_{ft} + Z_t}$ are the voltage reflection

coefficient at the upper and lower tower end; $V(t)_{to} = I(t)Z_{ch}$ is the initial tower voltage;

n = reflected wave point; $Z_{ch} = \frac{0.5Z_gZ_t}{0.5Z_g + Z_t}$, is the impedance from the striking point;

$a_{t2} = 1 + a_{r2} = \frac{2Z_{ch}}{Z_{ch} + Z_t}$, is the coefficient of voltage transmission; $T_t = \frac{h_t}{v_t}$, the time of travel

from the tower top to its foot or time of travel from the cross arm to the tower foot, h_t =height of the tower, v_t =velocity of traveling wave along the tower and t is a time constant taken by

traveling waves in case of lightning strike in μs ; $T_{ca} = \frac{h_{ca}}{v_t}$, the time travel from the cross arm to

the tower foot which is equal to T_t ; $Z_g = 60 \ln \frac{2h_s}{r_s}$, is the surge impedance of the shield

wire; $Z_{Pg} = 60 \ln \frac{d_{ps}}{d_{ps}}$; is the mutual surge impedance between the phase conductor and the shield

wire failure; $d_{p's}$ is the distance from the shield wire to the image of the phase conductor in the ground, and d_{ps} , is the distance from the shield wire to the phase conductor; h_s and r_s are the height and radius of the shield wire respectively. By neglecting the attenuation caused by impulse corona on the shield wire, the insulator voltage will be the same when a lightning stroke to tower or to shield wire [3, 15].

Thus, a shielded line has a lower lightning induced voltage in comparison with that for an unshielded line for the same return stroke current because of some currents will penetrate to the tower that is an advantage of a shield wire [3, 15]

3. When the lightning strikes a phase conductor for a shielded power line (shielded failure)

The perfect design for shielding power line should have the critical current equal to the shielding current[59]. The less intense lightning current strikes a shield wire i.e. I_p is less than the shielding current, it will cause shielding failures result for striking the phase conductors[30, 31, 62]. When the magnitude of the lightning current below the critical current level i.e. $I_p < I_C$ where $I_C = 2BIL/Z_p$ then, there is no outage occur. But, if lightning current is higher than the critical current $I_p > I_C$ of the line, there will be an outage [3, 5]. Some shield wires should design with few outages to reduce the cost of shielding. In that case shield wire will design according to the critical condition where insulator has a probability to withstand for a specific number of applications under specified conditions in case of lightning strike [3, 5]. The calculation of shielding failure rate is given by [63]:

$$N_{SF} = \frac{2N_g l}{10} \int_{I_C}^{I_{MSF}} D_c p(I_p) dI_p \quad (2.21)$$

Where, N_g is the lightning flash density from (2.1); l is the power line length; I_C is the minimum current required to withstand capability when lightning strike; D_c is the horizontal shielding failure exposure distance (2.22) [64] from Fig.2.18

$$D_c = r_s \left[\cos \left(\sin^{-1} \left(\frac{r_g - h_p}{r_s} \right) \right) - \cos \left(\tan^{-1} \left(\frac{\alpha}{h_s - h_p} \right) \right) + \sin^{-1} \left(\frac{d_{sp}}{2r_s} \right) \right] \quad (2.22)$$

$p(I_p)$, is the probability density function for the return stroke current from [59, 65-67] and it is given by equation (2.23); I_{MSF} , is the maximum shielding failure lightning current in kA that the ground wire will allow to strike the phase conductor due to the placement of the ground wire from[62], and it is given by equation (2.24)

$$p(I_p) = \frac{1}{\sqrt{2\pi} \cdot I_p \cdot \sigma_{\ln I_p}} \cdot \exp \left[-\frac{(\ln I_p - \ln I_{pm})^2}{2(\sigma_{\ln I_p})^2} \right] \tag{2.23}$$

$$I_{MSF} = \left[\frac{\frac{\gamma}{2}(h_s + h_p)}{10(1 - \gamma \cdot \sin \alpha)} \right]^{1/0.65} \tag{2.24}$$

Where, I_{pm} , is the median values of return stroke current value (I_p); $\sigma_{\ln I_p}$; is the standard deviations of $\ln I_p$; h_s ; is the ground or shield wire height; h_p , the height of the conductor at tower; α ; is the shielded angle and constant value $\gamma = \frac{1}{\beta}$, β is calculated by equation (2.25) from [62]; $r_s = 10I_p^{0.65}$ is the striking distance to the phase conductor ; $r_g = 0.9r_s$ is the striking distance to the ground.

$$\beta = 0.36 + 0.17 \ln(43 - h_p) \text{ for } h_p < 40m \text{ and } \beta = 0.55 \text{ for } h_p > 40m \tag{2.25}$$

The values of I_{pm} and $\sigma_{\ln I_p}$ have been analyzed [3, 16, 64, 66, 67], and they are given as follow:

For $I_p < 20kA$ then $I_{pm} = 61.1kA$ and $\sigma_{\ln I_p} = 1.33$ used for shielding failures

and

For $I_p > 20kA$ then $I_{pm} = 33.3kA$ and $\sigma_{\ln I_p} = 0.605$ used for backflashover.

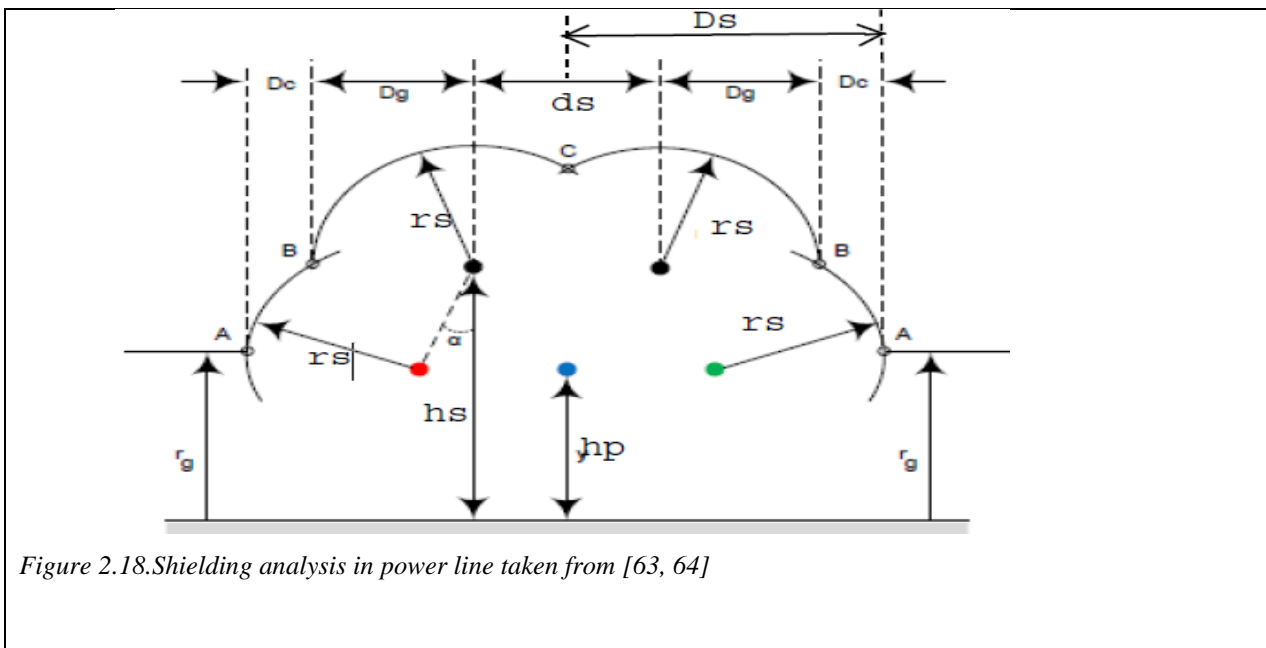

The critical current for a shielded line should higher than that for an unshielded line because the presence of the grounded shield wire reduces the effective surge impedance of the line.

It is note that the effects of induction for direct stroke due to the unshielded wire have more impact to a power line than due the shielded.

1. Indirect strike

Indirect strike occurs when a lightning strikes an object such as trees or churches or tall building nearby a ground of the power line, there is an increase in earth potential causing overvoltage in installations near the strike via their earthing electrodes[3, 4] Fig.2.19 and it may also occur when a currents induce electromagnetic induction due to lightning discharge in the immediate vicinity of the line caused by the presence of charged clouds Fig.2.20

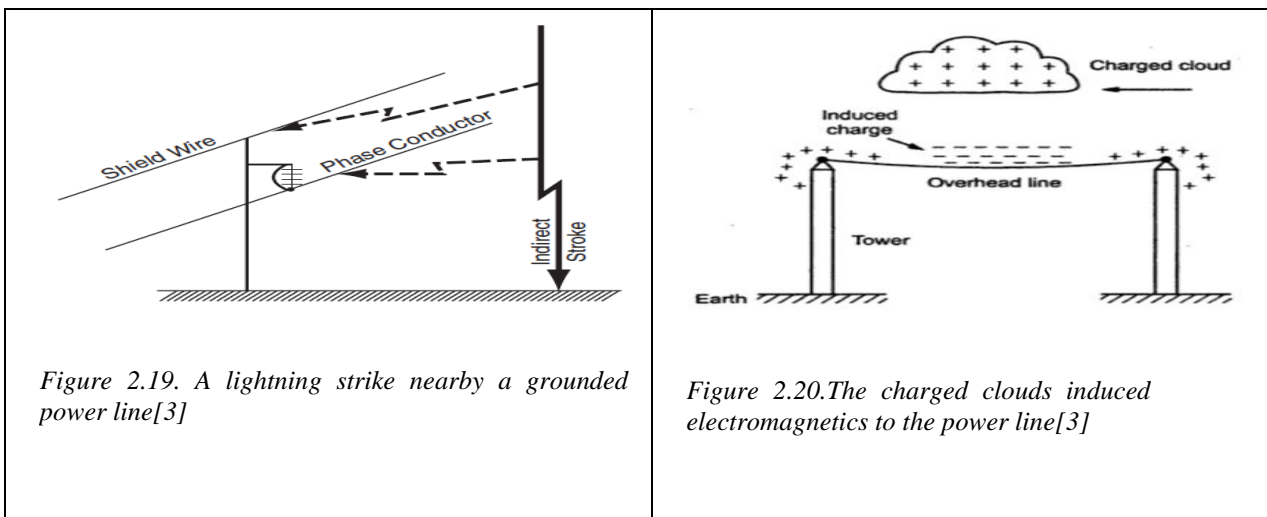

The effect of indirect strokes and direct strokes are almost similar because they cause an outage or destroy equipments but the effect caused by indirect strike is more severe in case of distribution lines than in case of high voltage transmission lines[68] due to the electric and magnetic fields of the lightning channel can induce high voltage on the line for the insulators of the low-voltage distribution lines to spark over causing a short circuit of the system[4].

According to the Chowdhuri,2001 [3], the total induced Electric field, E_i is the sum of the electric field due to charge of the lightning stroke, E_{ei} and the electric field due to the return stroke current, E_{mi} .

The summarized formula is given by: $E_i = E_{ei} + E_{mi}$

The researchers [3] [68] [69] have been worked on the lightning over voltages and they found that the induced voltages on a line by an indirect lightning stroke has four components as described below:

The first component is when the charged cloud above the line Fig.2.20 induces bound charges on the line while the line itself is held electrostatically at ground potential by the neutrals of connected transformers and by leakage over the insulators. Then, the cloud is partially or fully

discharged, these bound charges are released and travel in both directions on the line by giving rise to the traveling voltage and current waves[3].

The second component is when the charges lowered by the stepped leader further induce charges on the line, then, the stepped leader is neutralized by the return stroke, the bound charges on the line are released and thus produce traveling waves similar to that caused by the cloud discharge.

The third component is the residual charges on the upper part of the return stroke induce an electrostatic field in the vicinity of the line and hence an induced voltage on it as shown in Fig2.19

The fourth i.e. the last component is the rate of change of current in the return stroke produces a magnetically induced voltage on the line.

Consider a fig 2.20 a positively charged cloud is above the line that it induces negative charge on the line by electromagnetic induction which is present in that portion of the line under the cloud while the other portions of line are positively charged. The induced positive charges slowly leak to the earth through the insulators[68]. Whenever there is discharge from the cloud to earth or to another cloud, the negative charge on the wire is isolated as it cannot move quickly to the earth over the insulators. Due to this, negative charge goes along the line in both directions in the form of travelling waves, then, there is an indirect lightning strokes causes the maximum surges in a transmission lines. The same action will take place but with opposite charges for the cloud charged negatively. In a previous work [70], the authors developed a formula to compute the peak value of induced voltages an overhead line with a fixed front time of $3.8 \mu\text{s}$ but the further improvement was done by take into account to the stroke current front-time T in the range $1 \mu\text{s} \leq T \leq 12 \mu\text{s}$ and a return-stroke velocity v in the range $30 \text{ m}/\mu\text{s} \leq v \leq 150 \text{ m}/\mu\text{s}$ [13].

A Fig.2.22 shows the different parameters for computing induced peak voltage in case of lightning strike with respect to the position of striking point nearby an overhead power line and for Fig.2.21, when lightning stroke falling between point A and point B in that case, it will strike a phase conductor resulting the direct strokes; those falling outside AB will strike the ground result an indirect stroke for inducing voltages on the line[69].

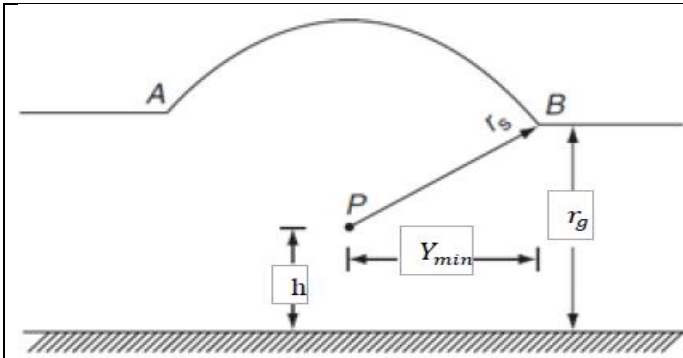

Figure 2.21: Electro-geometric model for estimating the least distance of ground strike[71]

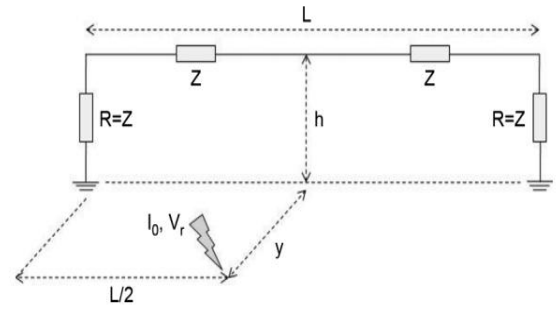

Figure 2.22: Line parameters and lightning stroke relative position[13]

The maximum voltage a lightning strokes induced in power line in case of striking nearby an object proposed by [69], [13] Fig.2.22 is:

$$V_P = k(V_R + V_S) \tag{2.26}$$

For the first stroke, the value of the constant k was adjusted as $k = 0.915$ in order to optimize the induced peak voltage and for subsequent strokes the value of the constant k was adjusted as $k = 0.90$ [69].

Where V_R is the indirect induced voltage by considering a perfect soil, V_S indirect induced voltages include the contribution of finitely conducting soil, and the factor k is the delay factor between the voltages V_R and V_S .

$$V_S = \sqrt{3} v_r^{1/3} I(t) \sqrt{\rho/y}$$

$$V_R = 15. I(t) \cdot \frac{h}{y} \cdot \frac{\varphi}{\eta} \cdot \ln \left\{ \frac{1 + [\sqrt{1 + \eta^2} + \eta]^2}{1 + [\sqrt{1 + \eta^2} - \eta]^2} \right\}$$

Where, $\varphi = 1 + \frac{v_r}{\sqrt{2(1-v_r^2)+(v_r-1)^2}}$; $\eta = 150v_r t_f/y$; $I(t)$ is the lightning returns stroke

current in function of time from equation (2.12); y , is the closest distance between the lightning striking point and the line, v_r is the relative velocity of the return stroke; y , is the interval distance between a grounded power line and lightning striking an object; t , is the interval time constant; c is the velocity of light in free space; t_f , the return stroke front time in μs , and h , is the line height in meters; T_1 , the time constant determine the current-rise time; T_2 is the time constant determine the current-decay time; n , current steepness factor which is 10 and $v_r = v/c$; the return

stroke velocity v [3] decrease with height which is equal to one third of velocity of light at free space $10^8 m/s$ and ρ is the soil resistivity. The soil resistivity is calculated as $\rho = 2\pi\sigma R_{tf}$

Where σ and R_{tf} are the grounded resistance and the electrode separations respectively.

For preventing the induced voltage to a power line caused by indirect strike, a tall object should place away from an overhead power line at the minimum distance Y_{min} with respect to the line height and return stroke lightning current distributions so that a lightning stroke should not divert to the line [49].

$$Y_{min} = \sqrt{r_s^2 - (r_g - h)^2} \quad (2.27)$$

Where $r_g = 0.9r_s$ is the striking distance to the ground (m) [43, 72] and $r_s = 10I_p^{0.65}$ is striking distance to the line conductor Fig.2.21. The value of r_s is calculated by taking the upper limit of the return stroke current interval, I_p varies from 1kA to 200kA in step of 0.5kA [5, 57].

An assessment of the annual indirect lightning induced voltage flashover rate of an overhead line, 2 km long, 10 m height, in a region with one ground flash per km^2 per year, equation (2.20) is used.

$$V_P = k(V_R + 0.8V_S) \quad (2.28)$$

These two equations (2.29 & 2.30) from [69], [13] are relative to the return stroke velocity of the current peak value for the first stroke, they should be used for assessment of the lightning performance of overhead lines. The equation (2.29) is related to the calculations proposed by Lundholm and Rusck and the equation (2.30) is obtained from field test data proposed by the IEEE T&D Committee.

$$v_r = \left(1 + \frac{500}{I_p}\right)^{-1/2} \quad (2.29)$$

$$v_r = 0.5 \operatorname{erf}(0.016I_p) \quad (2.30)$$

The induced voltage caused by indirect effect on power line depend on the striking distance from an object, as the striking distance from an object is small the higher induced voltage and it will reduce when the striking distance from an object to the power line became larger [49, 73].

2.4 Calculations of outages rate caused by effect of lightning strike in the power line

According to Chowdhuri, Grigsby and Yan [3, 65], the outages rate caused by the effect of lightning in the power line was calculated. These calculations of outages rate could help to evaluate the power line lightning protection that it should give the way for improving the methods of protections as well as the requirement parameters could help to reduce or eliminate failure and

back flashover in the power line in case of lightning stroke. Chowdhuri and Yan [3, 16] determined the outages rate due direct effect , Chowdhuri and Grigsby [3, 65] determined the outages rate caused by the indirect effect.

2.4.1 Outage rate caused by direct to phase conductor unshielded power line

When a lightning stroke to the phase conductor for unshielded line and the phase conductor critical current is less than the stroke current i.e. $I_c < I_p$, it may cause an outage rate. This outages rate is given by [3, 16]:

$$nfp = nfpo + n_g n_{sp} \sum_{t_f} \sum_I P_c(I) p(t_f) \Delta t_f \Delta A_p \quad (2.31)$$

Where, $nfpo = n_g P_c(I_c) p(t_f) \Delta t_f n_{sp} A_p$ the number of outages for lightning strokes falling within to the attractive area of the phase conductor A_p along the 100km length of the power line for 1kA of the return stroke current; n_{sp} is the number of span per 100 km of the power line; n_g is the ground flash density per km^2 per year from equation (2.1) ; $P_c(I_c)$ is the cumulative probability of return stroke current equal to or greater than the critical current to phase conductor I_c for equation (2.32), to phase conductor; Z_p is the surge impedance of the phase conductor; $p(t_f)$ is the probability density function of front time (t_f) equation (2.33), t_f was varied from 0.5 to 10.5 μs with the front time step size, Δt_f of 0.5 μs .

$$P_c(I_c) = 0.5 \operatorname{erfc}(u) \text{ where } u = \frac{\ln I_c - \ln I_{pm}}{\sqrt{2\sigma_{\ln I_p}}} \quad (2.32)$$

$$p(t_f) = 0.5 \operatorname{erfc}(v) \text{ where } v = \frac{\ln t_f - \ln t_{fm}}{\sqrt{2\sigma_{\ln t_f}}} \quad (2.33)$$

Where, $\operatorname{erfc}(u)$ is the complimentary error function of u ; I_{pm} and t_{fm} are the median values of return stroke current value (I_p) and front time t_f respectively; $\sigma_{\ln I_p}$ and $\sigma_{\ln t_f}$ are the standard deviations of $\ln I_p$, and $\ln t_f$ respectively.

If a return stroke current increase by a step of $\Delta I = 0.5\text{kA}$, then, the stroke current value will become $I = I_c + \Delta I$ and the enlarged attractive area A_{p1} . The lightning strokes with currents I or higher falling within A_{p1} will cause outages.

The additional outage rate due to increase a step of 0.5kA to the critical current value will be

$\Delta nfp = n_g P_c(I) p(t_f) \Delta t_f n_{sp} \Delta A_p$ is added to $nfpo$ where $\Delta A_p = A_{p1} - A_p$; A_p the attractive areas of the phase conductor are: $A_p = w_p l_s - A_t$; w_p the attractive width of a multiconductor

overhead lines equation (2.35); $P_c(I)$, the cumulative probability of return stroke current equal to or greater than the critical current I (2.34);

$$P_c(I) = 0.5 \operatorname{erfc}(u) \text{ where } u = \frac{\ln I - \ln I_{pm}}{\sqrt{2\sigma_{\ln I_p}}} \quad (2.34)$$

$$w_p = 2\sqrt{r_s^2 - (r_s - h_p)^2} + d_p \text{ for } r_s > h_p \text{ or } w_p = 2r_s + d_p \text{ for } r_s \leq h_p \quad (2.35)$$

$h_p = h_{pt} - \frac{2}{3}(\text{midspan sag})$; h_{pt} is the height of the conductor at tower;

l_s is the span length i.e. the distance between two towers; $r_s = aI_p^b$ is the striking distance of the lightning stroke where a & b are constant values. The value of a is 8 or 10 and that of b is 0.65; h_p is the height of phase conductor; d_p is the separation distance between two outermost conductors and $d_p = 0$ for a single line conductor; A_t is the attractive area of the tower equation (2.36).

$$A_t = \pi w_l w_t \quad (2.36)$$

The minor axis $2w_l$, along a line midway between the two outer phase conductors and parallel to their axes; the major axis of the ellipse will be $2w_t$, then,

$$w_l = \sqrt{r_s^2 - (r_s - h_t + h_p)^2} \quad (2.37)$$

and

$$w_t = \sqrt{r_s^2 - (r_s - h_t)^2} \text{ for } r_s > h_t \text{ and } w_t = r_s \text{ for } r_s \leq h_t \quad (2.38)$$

h_t : the tower height and h_p : the height of the conductor at tower.

The values of I_{pm} , $\sigma_{\ln I_p}$, t_{fm} and $\sigma_{\ln t_f}$ have been analyzed [3, 16] and they are given as follow:

$$t_{fm} = 3.83\mu\text{s}; \sigma_{\ln t_f} = 0.553$$

$$\text{For } I_p < 20\text{kA then } I_{pm} = 61.1\text{kA and } \sigma_{\ln I_p} = 1.33$$

$$\text{For } I_p > 20\text{kA then } I_{pm} = 33.3\text{kA and } \sigma_{\ln I_p} = 0.605$$

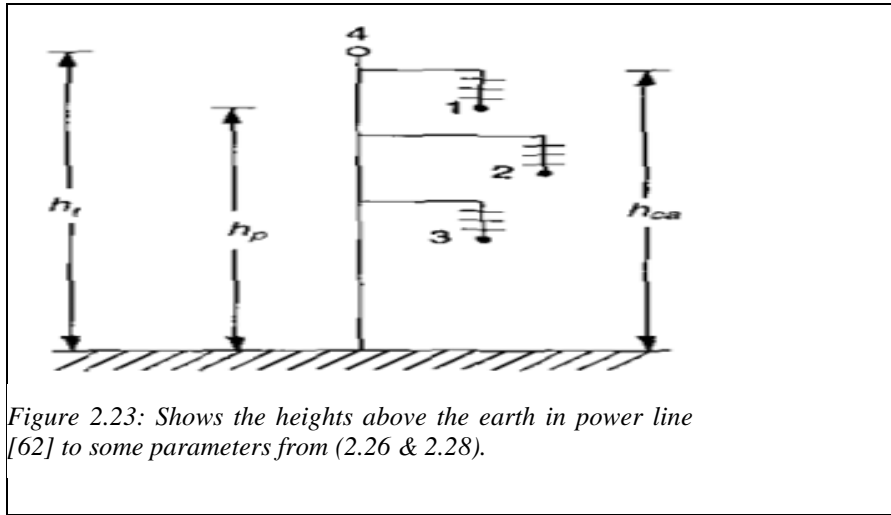

2.4.2 Outages rate caused by direct strike to a tower unshielded power line

As lightning stroke to the phase conductor for unshielded line cause an outage rate and there is also an outage caused by lightning when it hits of the tower for unshielded line for the insulator voltages might greater or equal to the BIL voltage i.e. $V_{ins} \geq V_{BIL}$, then, the outages rate are given by [3, 16]:

$$nft = nfto + n_g n_t \sum_{t_f} \sum_I P_c(I) p(t_f) \Delta t_f \Delta A_t \tag{2.39}$$

Where, $nfto = n_g P_c(I_{ct}) p(t_f) \Delta t_f n_t A_t$ is the number of outages for lightning strokes falling within to the attractive area of the tower A_t along the 100 km length of the line for 1kA of a return stroke current; n_t is the number of towers per 100 km of the line; $I_{ct} = \frac{BIL}{V_{ins}}$ is a critical current for stroke to a tower with $V_{ins} = V_{ca}$ from equation (2.15); $P_c(I)$, the cumulative probability of return stroke current equal to or greater than the critical current I (2.34) but with $I = I_{ct} + \Delta I$; The lightning strokes with currents I or higher falling within A_{t1} will cause outages and $\Delta A_t = A_{t1} - A_t$; A_{t1} , the enlarged attractive area to the tower at $I = I_{ct} + \Delta I$; $\Delta I = 0.5\text{kA}$, return stroke step size; A_t is the attractive area of the tower equation (2.36); $\Delta t_f = 0.5\mu\text{s}$, is the front time step size; $p(t_f)$, is the probability density function of front time (t_f) equation (2.33); n_g is the ground flash density per km^2 per year from equation (2.1); $P_c(I_{ct})$ is the cumulative probability of return stroke current equal to or greater than the tower critical current I_{ct} (2.40)

$$P_c(I_{ct}) = 0.5 \operatorname{erfc}(u) \text{ where } u = \frac{\ln I_{ct} - \ln I_{pm}}{\sqrt{2\sigma \ln I_p}} \tag{2.40}$$

The total outages rate of the direct unshielded wire is the summation of the outages rate caused by the direct stroke to the phase conductor and to the tower for unshielded power line which is given by:

$$nfo = nfp + nft \quad (2.41)$$

2.4.3 Outage rate caused by direct strike to shielded power line

As we computed above, where there were an outages rate caused by the direct shield wire, they are also an outages rate of the direct shielded lines due to the insulator voltages might greater or equal to the BIL voltage level i.e. $V_{ins} \geq V_{BIL}$, then, the outages rate should computed from [3, 16]:

$$nfp = nfpo + n_g n_{sp} \sum_{tf} \sum_l P_c(I) p(tf) \Delta t f \Delta A_p \quad (2.42)$$

Where, $nfpo = n_g P_c(I_{ct}) p(t_f) \Delta t_f n_{sp} A_p$ the number of outages for lightning strokes falling within to the attractive area of the phase conductor $A_p = w_p l_s - A_t$ for a shielded power line along the 100km length of the line for 1kA of the return stroke current. The critical current value of the tower for the shielded power line is computed as follow: $I_{ct} = \frac{BIL}{V_{ins}}$ where $V_{ins} = V_{ca} - k_{sp} \cdot V_{tt}$ from equation (2.18).

$w_l = \sqrt{r_s^2 - (r_s - h_t + h_s)^2}$; $w_p = 2\sqrt{r_s^2 - (r_s - h_s)^2} + d_s$ for $r_s > h_s$ or $w_p = 2r_s + d_s$ for $r_s \leq h_s$; h_s is a shield wire height and the d_s is the separation distance between two outermost shield wires and $d_s = 0$ for a power line with one shield wire

The others parameters should compute in the same manner as of the outages rate direct stroke due to unshielded line in the sub-chapter 2.3.1.

The insulations withstand on the power line in the presence of shield wire and it will failure due to the absence of shield wire (unshielded) [5, 15]. The substation should generally shielded with a shield wire in order to prevent high current faults caused by direct lightning stroke close to the substation which could damage the substation transformers and breakers. To shielded a power line should be an effective way for reducing lightning induced faults.

2.4.4 Outages rate caused by indirect effect to the power line

The direct lightning strokes cause an outages rate was computed and there is also the outages rate caused by the indirect strike. The flashover occur when the lightning strike a ground or an object

nearby the grounded power line and the induced voltages exceed the capability to withstand i.e. BIL level of the power line [65].

The expected power line flashovers nfo per 100 km per year is given by:

$$nfo = p(I_P, t_f) \cdot \Delta I_P \cdot \Delta t_f \cdot n_g \cdot A \quad (2.43)$$

Where $p(I_P, t_f)$ is the joint probability density function (2.44);

$$p(I_P, t_f) = \frac{e^{-\frac{0.5}{1-\rho^2}(f_1 - 2\rho\sqrt{f_1 f_2} + f_2)}}{2\pi(I_P \cdot t_f)(\sigma_{lnI_P} \cdot \sigma_{lnt_f})\sqrt{1-\rho^2}} \quad (2.44)$$

Where, $p(I_P) = \frac{e^{-0.5f_1}}{I_P \cdot \sigma_{lnI_P} \sqrt{2\pi}}$ and $p(t_f) = \frac{e^{-0.5f_2}}{t_f \cdot \sigma_{lnt_f} \sqrt{2\pi}}$ and the expressions of f_1 and f_2 are

computed as: $f_1 = \left(\frac{\ln I_P - \ln I_{Pm}}{\sigma_{lnI_P}}\right)^2$ and $f_2 = \left(\frac{\ln t_f - \ln t_{fm}}{\sigma_{lnt_f}}\right)^2$; the front time t_f varied from 0.5 to

10.5 μ s with the front step size; Δt_f of 0.5 μ s and the return stroke current I_P varied from 1 to 200 kA with step size; ΔI_P of 0.5 kA; n_g is the ground flash density per km² per year; $p(I_P)$ and $p(t_f)$ are the probability density function of the return stroke current and front time respectively and $\rho = 0.47$ is a correlation coefficient.

Equivalent attractive area A could cause a flashover in power lines is estimated as $A = l(d + 2R_a)$ where l power line length in km; d is effective width at the horizontal distance between overhead shield wires or between the outer phase conductors; and R_a equivalent attractive distance generally which is in function of a structure height. $R_a = \alpha h^\beta$ where $\alpha = 14$ and $\beta = 0.6$ [10].

The total number of flashovers per 100 km per year for a selected BIL will get it by adding nfo per 100 km per year and the new computed in considering front time increased by 0.5 μ s.

Note: The outage rates caused by the direct effect stroke to the three phase overhead power line have more impact than indirect effect Chowdhuri and Grigsby [5] [3].

2.5 Lightning overvoltages in power line networks

The method for improvement performance of lightning protection in power systems are to increase insulation line, installation an overhead ground wire, improving the tower footing resistance and installation of transmission line surge arrestors. An insulation line should design to have the capability of higher level than their maximum instantaneous voltage in steady state value and which are exposed to overvoltages or over currents that exceed its withstand levels [68, 74].

The effects of direct strokes on power line are key factors in the selections of lightning protections because of higher energy produced which can exceed the capability of the power line equipment, consequently the damage of the transformers. In lightning protection studies the ground flash density is one of the important parameters necessary in making decisions concerning the vulnerability of structures to lightning [4].

The transient disturbances on the power line networks cause the serious negative effects of the power reliability and they are definitely more often during thunderstorms, lightning activity, and in specifically the lightning indirect effects are therefore, considered as one of the main causes for power interruption disturbance. According to the limited height of medium and low voltage power line distribution networks compared to that of the structures in their nearness, indirect lightning return strokes are indeed more frequent events than direct strokes[75]. The fundamental principle of a lightning protection system is to realize a low impedance pathway for the electrostatic discharge into the ground without a big damage. The electrical conductivity of the metal should be high from the collection device or apparatus to the ground.

2.5.1 High Voltage Transmission Network Lightning protection

The protection against the direct lightning stroke in the high voltage transmission line should done by the use of shield wires and surge arrester. The Overhead ground wires (OHGW) play an important role for reducing the magnitude of surge voltage and for protecting against the traveling waves induced in the conductors due to electrostatics induction from the charges cloud travel to the phase conductors [76]. The shield wire is installed on tower top of the power line, it will use to reduce the probability of direct stroke to phase conductor by collecting most flashes to divert to the ground and it is also used to reduce the magnitudes of the overvoltage associated with indirect strokes [17, 77]. The ground wire resistances should be small in the range of 5 Ohms to 15 Ohms and it will increase in size by increase the value of electromagnetic coupling factor. The electromagnetic coupling factor help to reduce the induced overvoltage across insulators [3, 15, 16].

The induced voltage could reduce by increasing the capacitance between the phase conductor and the earth in the presence of ground wire. The presence of one shield wire will be reduced the induced voltage in the power line to one half, for the use of two ground wires will be reduced to one third and for the use of three ground wires will be reduced to one fourth [76]. A surge

arrester could use in protection against high voltage surge and to divert atmospheric discharges to ground which is the result in limiting the overvoltage in the equipment for which they provide to protect [63]. They play an important role in substations for preventing the switching and lightning surges directly conduct these surges to ground. The numbers of surge arrester and their placement in high voltage substations could be determined based on evaluations in the designing process of substations. The surge arresters could be placed on the both ends of substations, transformers, circuit breakers, reactors, capacitors and high long bus bars etc. Therefore, the arresters failures during overvoltage can put power line in risk condition [78]. The surge arresters are made in semiconductors with a characteristic of resistance, which can vary from few to various ohms, in their operation mode the impedance is high at normal condition mode and become lower when the overvoltage occurs in the circuit. The main characteristic of surge arrestors is the maximum continuous operating voltage (MCOV), which is bigger than the maximum power line operating voltage with a safety tolerance of 5 % of estimated voltage, which must be $1.25 \times \text{MCOV}$ protection level. A perfect lightning arrester must satisfy the following conditions: (1) Ensure conductivity of electric current at a certain voltage above the nominal voltage; (2) Maintain the voltage with a small change of variation during an overvoltage period; (3) stop considerably conduction at very nearly the same voltage at which conduction began (4) ability to withstand the energy of transient overvoltage. Nowadays many types of arresters are available on the market such as the gapped silicon carbide, gapped and non-gapped metal-oxide. The working principle of those arrestors remains the same. However the arrestors with metal oxide present a great advantages of, simplicity in design, which increase overall quality and decreases moisture ingress, and high energy absorption capability compare to gapped silicon carbide[79].

The arrester Energy E (in Joules) can absorb during lightning strike [63, 74, 78] is computed by equation (2.45):

$$E = \int_{t_0}^t U_p(t) i(t) dt \quad (2.45)$$

Where E is the energy released in the surge arrester during the lightning; U_p is the residual voltage across the surge arrester in kV; $i(t)$ is the discharge current through the arrester in kA; t_0 , is the moment when lightning strikes the surge arrester terminal and t is the time duration that the current is applied to it.

When the absorbed energy by the arresters exceeds their maximum acceptable level, they will failures or damages. The surge arresters are the last protection measure of a transmission line, if

an arrester failure is considered as a line fault. The arrester failure rate is calculated by in consideration of two ways [63, 74, 78]: by striking the phase conductor and producing the arrester failure (2.46) and by striking the OHGW and producing the arrester failure (2.47).

$$FR_P = N \int_{T_t}^{\infty} \left\{ \int_{I_A(T_t)}^{\infty} f(I_P) \cdot h_A(I_P) dI_P \right\} g(T_t) dT_t \quad (2.46)$$

$$FR_S = N \int_{T_t}^{\infty} \left\{ \int_{I_B(T_t)}^{\infty} f(I_P) \cdot h_B(I_P) dI_P \right\} g(T_t) dT_t \quad (2.47)$$

The total arrester failure rate is determined by summing the arrester failure rate to the phase conductor and to the OHGW (2.48).

$$FR = N \left[\int_{T_t}^{\infty} \left\{ \int_{I_A(T_t)}^{\infty} f(I_P) \cdot h_A(I_P) dI_P \right\} g(T_t) dT_t + \int_{T_t}^{\infty} \left\{ \int_{I_B(T_t)}^{\infty} f(I_P) \cdot h_B(I_P) dI_P \right\} g(T_t) dT_t \right] \quad (2.48)$$

Where, N , is the number of direct flashes to a power line given by equation (2.10); $I_A(T_t)$, is the minimum stroke peak current kA required to damage the arrester when lightning strike a phase conductor with respect on time-to-half value; $I_B(T_t)$ is the minimum stroke peak current in kA required to damage the arrester when lightning strike an overhead ground wire with respect on time-to-half value, $f(I_P)$ is the probability distributions of the peak current I_P (2.49) and $g(T_t)$ is the probability distributions of the time-to-half value T_t (2.50) [80]; $h_A(I_P) = \frac{D_c}{D}$; $h_B(I_P) = 1 - \frac{D_c}{D}$; D_c , is a shielding failures exposure distance Fig.2.18 and D , is the vertical distance between the intersection point C and intersection point A Fig.2.18 [63, 74, 78].

$$f(I_P) = \frac{n_c}{I_{50}^{n_c}} \cdot \frac{I_P^{n_c-1}}{\left[1 + \left(\frac{I_P}{I_{50}} \right)^{n_c} \right]^2} \quad (2.49)$$

$$g(T_t) = \frac{n_t}{T_{50}^{n_t}} \cdot \frac{T_t^{n_t-1}}{\left[1 + \left(\frac{T_t}{T_{50}} \right)^{n_t} \right]^2} \quad (2.50)$$

The values of n_c , n_t , I_{50} and T_{50} must deduced from experimental [80] where $n_c = 2.6$ and $I_{50} = 30.1k$ recommended from [81] and $n_t = 1.82$ And $T_{50} = 30\mu s$ from [80].

They are also a shielding failure rate and back flashover in power line transmission networks caused by lightning strike due to the stroke current exceed the BIL value. The methods of calculating shielding failure rate was described in equation (2.21) and the back flashover rate with or without ground wires from [63] is given by equation (2.51).

$$N_{BF} = N \int_{I_C}^{I_P} \int_{\left(\frac{di}{dt}\right)_{min}}^{\left(\frac{di}{dt}\right)_{max}} P(\delta) dI_p d\left(\frac{di}{dt}\right) \quad (2.51)$$

Where $P(\delta)$ is the probability distribution function of the random variable δ , which is a function of the two variables I_p and di/dt calculated as following:

$$\delta \left(I_p, \frac{di}{dt} \right) = R_{tf} I_p / (2 - 0.85 \cdot V + L \frac{di}{dt}) \quad (2.52)$$

If δ is greater than zero, there is a back flashover, $R_{tf}(\Omega)$ is the tower footing resistance; $L(\mu H)$ is the total equivalent inductance of the system (tower and grounding system's inductance); di/dt is lightning steepness expressed in $(kA/\mu s)$; $\left(\frac{di}{dt}\right)_{max} = 54.68$ and $\left(\frac{di}{dt}\right)_{min} = 11.65$ are the maximum and minimum steepness [55] respectively and I_p the peak lightning current in kA.

The total failure rate in the transmission line is given by the sum of all the failures rate which is equal to the sum of equations (2.21), (2.48) and (2.51).

11.65 54.68

The purpose of calculating failure rate may help us to evaluate the lightning protection in power transmission lines in order to improve lightning protection performance for increasing the insulation design probability overvoltage protections and also the improvement of installing surge arrester as well as to determine the footing resistance value requirement. By improving protection methods, the insulations flashovers and failure rate of the line cause power supply interruptions will reduce or eliminate.

2.5.2 Medium and Low Voltage Lightning Protection

It's difficult to protect transient disturbances caused by lightning stroke in electrical power distribution networks due to the relatively low insulation levels of the lines in comparison with the voltages can be developed by lightning surges[9, 12, 17]. These transient disturbances cause an interruption or damage a power distribution networks can develop during the period of thunderstorms where there were an increase of voltage (overvoltage) in the wiring system caused by atmospheric discharges.

The effect of lightning an overhead distribution network should protect using the air termination (shield wire or overhead ground wire) for protecting the effects caused by direct lightning stroke and surge arresters for preventing indirect effects of lightning strikes within the vicinity of the facility. Yokoyama, 2007 [9, 12, 17] and Central Research Institute of Electric Power Industry, 1997 [82] found that the effects of lightning should protect by using surge arresters alone or an overhead ground wire alone or the combination of surge arresters and an overhead ground wire Fig.2.24. The protection using surge arrester can perform nearly the same as using combinations of surge arresters and shield wire [82],[12] Fig.2.24 and Fig.2.25. The grounding

resistance of surge arrester play an important role in protection as shown in Fig.2.24. The induced voltage will increase relative to the surge arrester ground resistance. The increase the performance of the surge arrester, its ground resistance should be small Fig.2.24.

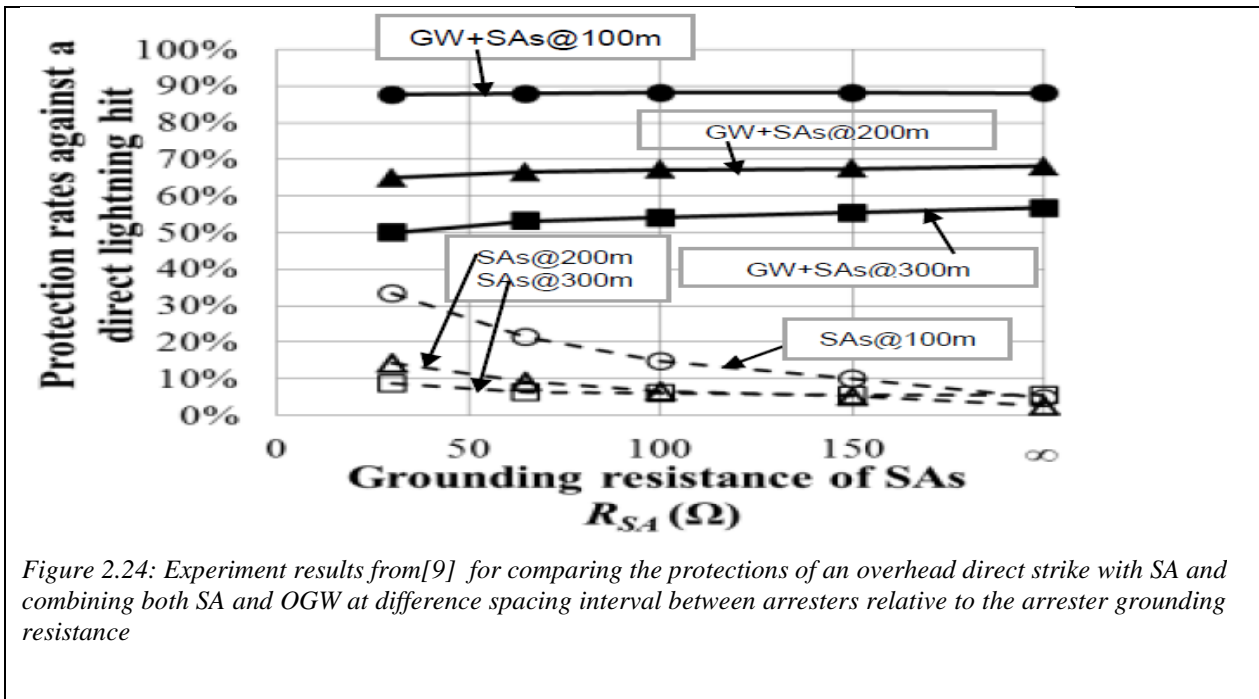

Fig.2.25 shows the induced voltage in case of direct lightning when there were no protections and by installations only OGW or only SA or by combination of OGW & SA [12]. The induced voltage is very high without any protection and decrease by installations of OGW. It will become low when the SA and combinations of SA & OGW are installed.

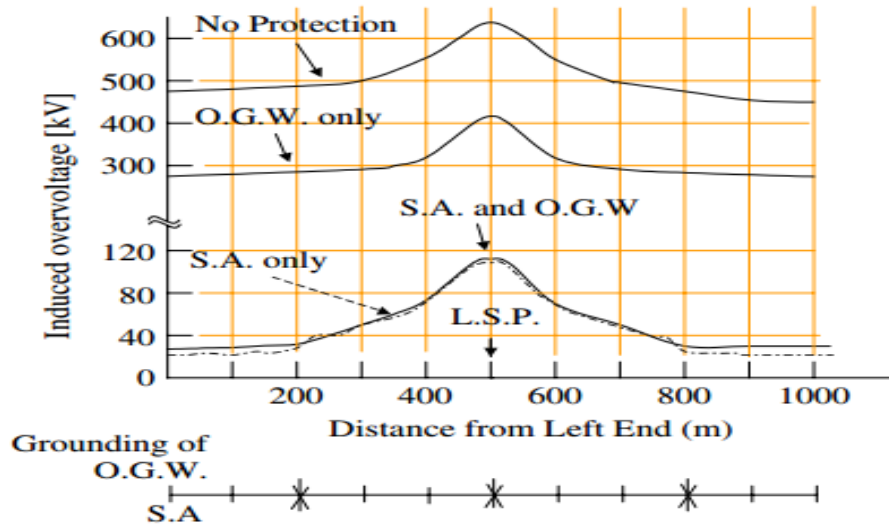

Figure 2.25: EMTP software results from [12] in the analysis of induced voltage in the power line due to lightning transient by using SA, OGW and combinations of SA and OGW

The use of surge arresters to protect an unshielded line against direct strokes, may have a significant failure rate due to the large amount of energy which exceeds to withstand capabilities caused by direct lightning stroke, consequently for damaging equipments such as transformers and systems [17, 74, 82] and the Central Research Institute of Electric Power Industry (CRIEPI) in their experience found that overhead ground wires are fairly effective against direct lightning strike [82].

The energy absorbed by a Metal oxide or Zinc oxide surge arresters, which cause failure of arresters, was analyzed by Yokoyama, 2027 [12] and CRIEPI, 1997 [82]. In the research & analysis of Yokoyama [12, 74] found that failure of surge arresters due to absorbed energy depend on the numbers of arresters installed in distribution networks, and they were suggested to increase effective surge arrester by installing it at all poles in consideration for a short distance interval between them at least 200m in order to reduce failures due to induced overvoltage.

For CRIEPI, 1997 [82] in their research, analysis and experience found that a direct lightning stroke with high energy in winter period increase number of outage of surge arresters where the energy absorption without an overhead ground wire is about 3 to 5 times larger than that with one shield wire and they suggested that, the installation of an overhead ground wire can reduce the failure probability of a surge arrester about 20 up to 30 %, and for increase withstand capability of a surge arrester can reduce it about 50 up to 70 % but the withstand capability of a surge arrester

is far smaller than the energy of a winter lightning stroke [82]. Both Yokoyama,2007 [12] and CRIEPI,1997 [82] suggested that the installations of combination of surge arresters and an overhead ground wire are more frequently used to protect equipments and line insulation against lightning an overhead power distribution lines Fig.2.24 and Fig.2.25. Thus, the installations of OGW increase the withstand capability of SA by reducing SA discharge current due to direct lightning [9, 12, 82]. Fig.2.26, shows an outage rate due to direct and indirect lightning by the use of OGW, SA as well as the use of combinations of OGW &SA.

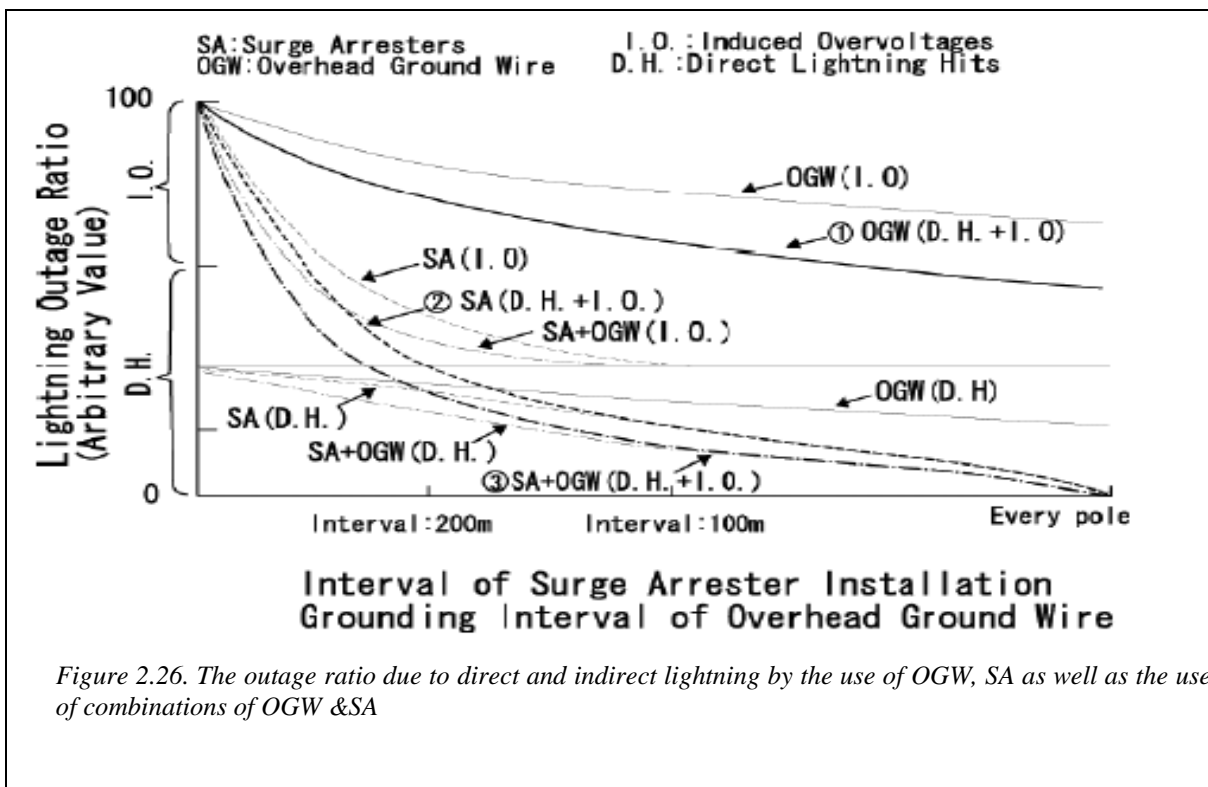

Figure 2.26. The outage ratio due to direct and indirect lightning by the use of OGW, SA as well as the use of combinations of OGW &SA

The additional cause SA failure are the absorption energy at the termination that is about of 1.1 up to 2.3 times larger than that of the arrester at the midst and the failure probability for a lightning stroke at the termination is 1.6 times higher than that for a stroke at the midst which reveals that the surge arresters at the termination are damaged more than those at the midst of a line. Therefore, the result of installation an overhead ground wire and surge arresters with larger withstand capabilities at the termination of a line [82].

A surge arrester used today has an internal a MOV (Metal Oxide Varistor) Disk as the heart of all arrestors which is a Semiconductor that is sensitive to Voltage. This MOV disk is considered as insulator at normal voltages and will not conduct current i.e. open switch but at higher voltages caused by lightning it becomes a conductor i.e. closed switch to divert atmospheric discharges to the ground by limiting overvoltage. Thus, the capability of surge arrestors is based on the amount of energy that a varistor disk can absorb before it fails. The main failure modes in the varistor elements of the surge arresters depend on thermal runaway due to current and voltage instability, puncture caused by current concentration, and cracking occurs because of the high thermal stresses. That energy is related to the point of incidence of the lightning, the amplitude of return stroke currents, the frequency of lightning incidents and the ground resistance and the failure probability of arrester.

Note that the installation of surge arresters may improve the distribution line performance with respect to indirect strokes and for shield wire with direct strike as well as it will improve the withstand performance of surge arrester. The earth resistance may have a significant influence on the induced voltage amplitude i.e. for lower values of footing resistance, the current that flows to earth through the surge arrester increases, thus increasing the value of the voltage component that, by coupling, reduces the voltages induced on the phase conductors, in addition, both end of lines should have a matching resistance which help to prevent current reflections in the network. Lightning voltage induced by nearby strokes is a major causes of overvoltages which threaten insulation of power distribution lines[83] Fig2.25. To prevent the induced overvoltage caused by indirect strike, power line could design with respect to equation (2.27) and by installing surge arresters every 200m.

2.5.3 Assessment of lightning transformer failures and protections

The purpose of a power system is to transport and distribute the electrical energy generated in the power plants to the consumers in a safe and reliable way by the use of a transformer. A transformer shall be used as stepped up when it connected to the generation stations for transmitting an electrical energy to higher voltage level over long distances and at the distribution level when it transforms the voltage down (stepped down) to the required level for the consumer. In other word, a transformer is an important equipment use in power systems to change power from one voltage or current to another[15]. It was designed to operate at any abnormal voltages or at any transient overvoltage but it was not sufficient to be fully protected, therefore, it need an

additional of the higher insulation level and higher protections against overvoltage transient for better performance by increasing its withstand capability [84]. A distribution transformer designed and manufactured with a specified basic impulse level BIL rating. This BIL rating determines the level of lightning and switching surge voltages that the transformer can withstand without damage [85]. The transformer surge impedance should much greater than that of the line because current flow through where there is a smaller resistance than it has a larger resistance. A transient disturbance caused by lightning strike might very dangerous to a power line and cause a transformer to damage. The natural phenomenon causes a transient disturbance like a lightning strike have been difficult to fully protect because of the relatively low insulation levels of a power lines in comparison with lightning overvoltage developed by lightning surges but it could be preventing[18]. A lightning strike to or nearby power distribution line causes failure rate of the transformer results for damaging it, which is very expensive as well as difficult to repair. Therefore, it's protections against lightning transient disturbance may highly very recommended and purchaser must specify a transformer meet the fully requirement standard withstand capability. A transformer might place in power line as pole mounted or Pad mount as shown in Fig.2.27 and Fig.2.28.

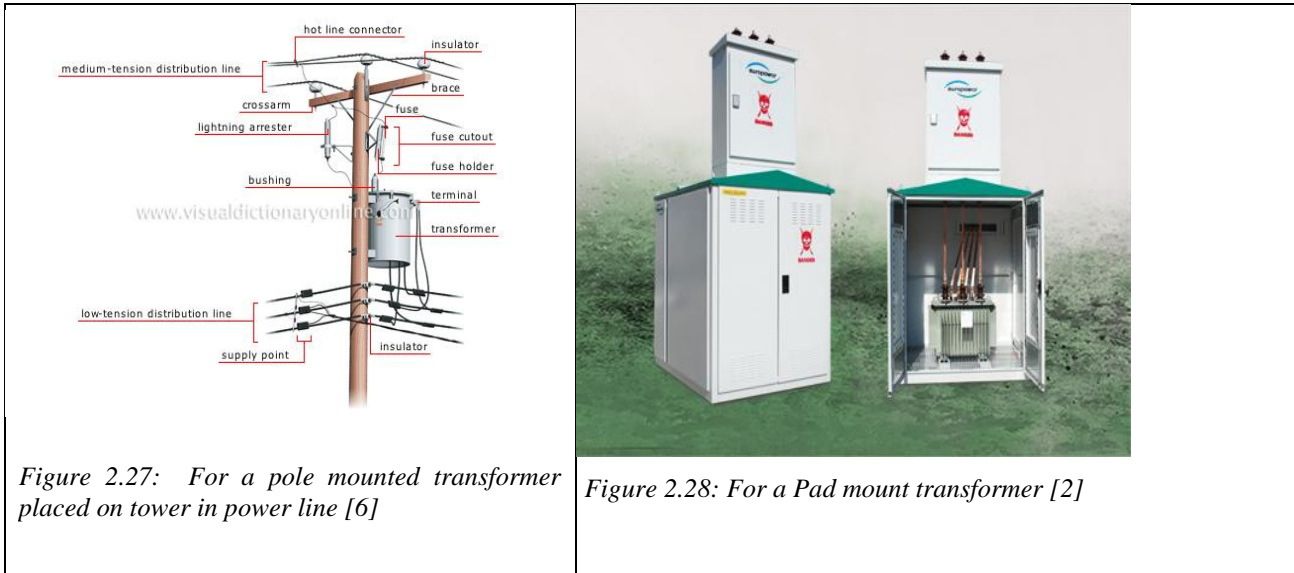

When a direct lightning strike to the MV or LV, the fast overvoltage arising at or transferred to the MV terminals of the distribution transformer will be higher in absence of a lightning surge arrester but with installation of SA will be greatly reduced and the fast overvoltage arising at or transferred to the LV terminals of the distribution transformer will be higher in the absence of SPD but it will become lower closer to normal voltage by installations of SPD and grounding resistance to the transformer LV side. The transformer grounding resistance might higher than to its grounding load resistance otherwise it will failure due the transformer overvoltage exceed its BIL level. The failure of MV or LV transformer distribution line had effect of transformer damage [86].

The distribution transformer failures rate should be done by summing the failure rates due to direct lightning strokes to the MV overhead line and to the object connected to the LV side [87]. Which will help us to evaluate the outage rates in order to improve its protections.

The transformer failure rate caused by direct stroke to the MV overhead power line (2.53)

$$F_{MV} = N_{MV} \int_{I_c}^{\infty} p(I_P) dI_P \tag{2.53}$$

Where, $p(I_P)$, is the probability density function for the return stroke current equation (2.23); $N_{MV} = [0.1N_g(2R_{eqc} + d)]$ flashes per year, is the rate of direct lightning flashes to the MV overhead power line; $d(m)$, is the separation distance between outer line conductors; $R_{eqc} = 6.2h^{0.3} \exp [0.455 \ln I_{pm} + 0.1(\sigma_{\ln I_p})^2]$ is the equivalent interception radius of line conductors; h the tower height; I_{pm} , is the median values of return stroke current value (I_P) and $\sigma_{\ln I_p}$; is the standard deviations of $\ln I_p$ [3, 16].

The transformer failure rate caused direct stroke to the object connected to the LV side is given by

$$F_T = N_T \int_{I_{FT}}^{\infty} p(I_P) dI_P \tag{2.54}$$

Where, I_{FT} , is the critical current to cause the flashover on LV transformer side;

$N_T = 10^{-6} N_g \pi R_{eqT}^2$, is the rate of direct lightning flashes to the tower;

$R_{eqT} = 1.22 \sin(\alpha)^{0.7} h^{0.5} \sqrt{\exp [2 \ln I_{Pm} + 2(\sigma \ln I_p)^2]}$, is the interception radius of the tower;

α is the shielding angle Fig.2.18.

According to the Lucas and Nanayakkara in their research and analysis, 2001 [18] found that a direct stroke to a power distribution line might cause a transformer failure due to the lack of proper analysis techniques, selection and installation of protection systems and lack for estimating separation distance between transformer and the surge arrester [88].

They were two methods to improve transformer protections proposed [18] by:

- i) estimating a separation distance between transformer & surge arrester as shown to Fig2.29 and
- ii) Choosing arrester with low residual voltages.

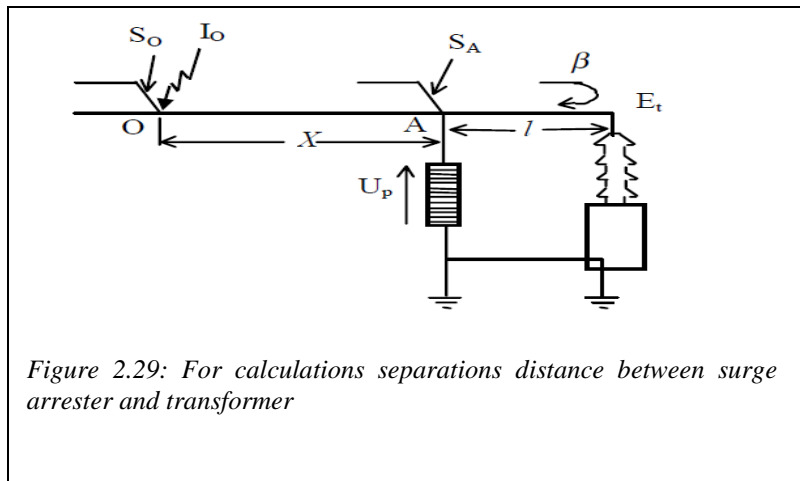

i) Estimation for the distance separations between transformer & surge arrester

The method for a transformer protection has proposed that the arrester location should determine in order to ensure a failure rate below a certain value during lifetime of a transformer. A transformer with a lifetime (LF) years and the acceptable failure rate (FR%) during the period of lifetime. The transformer should be protected if a direct lightning will occur only once in t_s years in case of a failure rate below FR%.

$$t_s = (LF/FR) * 100 \text{ years} \tag{2.55}$$

t_s is the duration between two lightning surges which cause damage to the transformer (years).

The number of direct stroke to a power line N depend on N_g Ground Flash Density, d the distance separations between the outer most 2 conductors; the H height above the ground which is similar to the tower height and S_f the shielding factor due to nearby objects vary from 0.3 to as high as 0.5 and it given by: $N = N_g(d + 28H^{0.6})(1 - S_f)10^{-6}$ Strokes/ Km year

(2.56)

The probability distribution of lightning current strike to phase conductor which is nearly connected to the transformer is given by equation (2.51) and is simulated in Fig2.30

$$P_{I_p} = e^{-0.02878I_p} \tag{2.57}$$

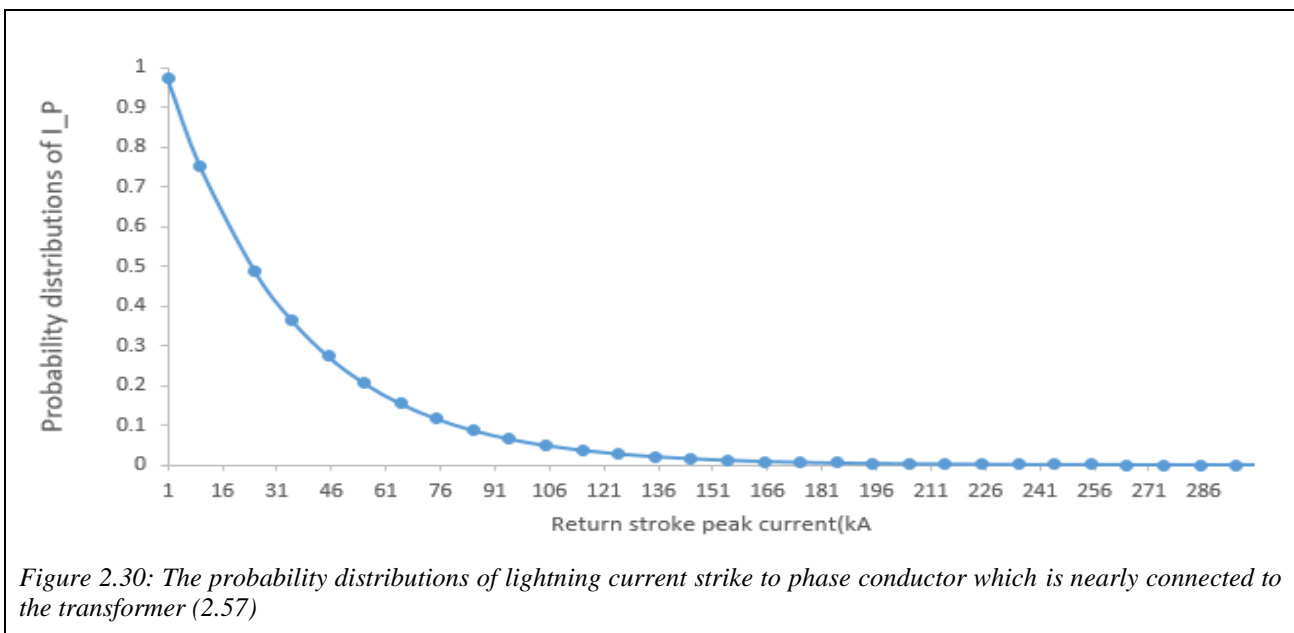

Figure 2.30: The probability distributions of lightning current strike to phase conductor which is nearly connected to the transformer (2.57)

The Probability of getting one lightning stroke is given by: $(1/N \cdot ts \cdot x) * 100\%$

x distance in which a surge with an infinite slope will decay to slope S_A at A (m)

The travelling wave voltage during direct lightning strike to the phase conductor is given by

Fig.2.29:

$$V = I_p / 2 \cdot Z_p$$

Where I_p the return stroke peak current and Z_p line surge impedance.

Referring from Fig2.29, l is the separation distance between surge arrester and transformer in meter and given by:

$$l = \frac{(0.8 E_t - U_p)v}{2S_A} \tag{2.58}$$

Where: E_t is the peak surge voltage at transformer in kV

$$E_t = U_p + \beta S_A \cdot \frac{2l}{v} \text{ for } S_A \cdot \frac{2l}{v} < U_p \text{ and the worst if } E_t = 2U_p \text{ for } S_A \cdot \frac{2l}{v} \geq U_p$$

U_p is the arrester residual voltage in kV ; v is the velocity of wave propagation which is $300m/\mu s$; β is the transformer reflection coefficient which is generally assumed equal to one;

S_A is a rate of rise of surge voltage at receiving end i.e. de/dt in $kV/\mu s$

$$S_A = \frac{1}{\frac{1}{S_o} + kt} \tag{2.59}$$

$k = 1.5 * 10^{-6}$ is a corona-damping constant in $\mu s/kVm$; S_o is the rate of rise at point of strike i.e. de/dt in $kV/\mu s$ and t_f is a wave front time in μs

$$S_o = \left(\frac{I_p}{2}\right) \cdot \left(\frac{Z_P}{t_f}\right) \tag{2.60}$$

For the given values below in Table 2.2 & 2.3 taken from [18] and $X=300$ the required l could be calculated.

Table 2.1: Transformer and power line parameters

3 phases	H	d	S_f	Z_p	BIL or E_t	U_p	FR	LF	C
33kV	9.2m	2.7m	0.5	450 Ω	200kV	110kV	5%	20years	300m/ μs

Table 2.2: Thunder day and GFD parameters

TD	5	10	20	30	40	50	60	80	100
N_g	0.2	0.5	1.1	1.9	2.8	3.7	4.7	6.9	9.2

The Probability of getting one lightning stroke is $(1/N \cdot ts \cdot X) * 100\%$

Table 2.3: Shows calculated value of l at $x=300m$ and $N_g = 6.9$

N	$t_s = \left(\frac{LF}{FR}\right) * 100 \text{ years}$	$(1/N \cdot ts \cdot X) * 100\%$	S_A	l
0.113 stroke per year	400 years	0.022	1627kV/ μs	4.6m

The calculated probability of getting one lightning strike is corresponding to the exceed value of $I_p = 135kA$. The total number of damaging surges in lifetime (LF)= $Nf * LF = 0.05$ which did not meet the requirement of the transformer protection because a transformer should be protected if a direct lightning will occur only once in t_s years.

Where Nf , number of lightning surges arriving at point A at Fig2.29 with a slope higher than S_A per year.

The value for $l = 4.6 \text{ m}$, a transformer should not be well protected for any value below or above to $I_p = 135 \text{ kA}$. Therefore, the improvement of the transformer protection might be recalculating the effective required l with the return stroke peak current I_{ox} with higher values than I_p , where I_{ox} has very few strokes probability numbers.

The increased return stroke peak current I_{ox} was given by:

$$I_{ox} = \frac{2t_f S_A}{(1 - S_A k x) Z_P} \quad (2.61)$$

Assume I_{ox} to be an infinity values from equation (2.61), then, the new values for X was calculated by: $X = \frac{1}{S_A k}$

By taking the $I_{ox} = 300 \text{ kA}$, the value of X is calculated by:

$$X = \left(1 - \frac{2t_f S_A}{300 Z_P}\right) \left(\frac{1}{S_A k}\right) \quad (2.62)$$

The number of direct stroke to the distribution line with I_{ox} was given by:

$$Nf = N \int_0^X e^{-i(x)} dx \text{ strokes per year} \quad (2.63)$$

$$i(x) = 0.02878 * \frac{2t_f}{Z} * \frac{S_A}{1 - S_A k x} \text{ and } N = N_g (d + 28H^{0.6}) (1 - S_f) 10^{-6}$$

Then, Nf is calculated which is equal to 0.0581 strokes per year. The recalculated total number of damaging surges in lifetime (LF) $Nf * LF = 1.162$ which is equal to that transformer was accepted. Thus, the transformer protection was improved. The new value of l is calculated using

$l = \frac{(0.8E_t - U_p)v}{2S_A}$ with acceptable $Nf = \frac{0.05}{LF} = 0.0025$ and the new value of S_A with I_{ox} and X from (2.62), then $l = 2.3 \text{ m}$.

They conclude by taking account into l to be as small as possible; fixing the surge arresters right top on of the cover plate of the transformer and putting the relative connections in 1m to 1.3m length by consideration the length of surge arrester to be around 1m of length.

According to [89], the interval distance between surge arrester and transformers in medium voltage is given by (2.64):

$$l = \frac{v}{2S_A} \left[\frac{BIL}{1.2} - U_p \right] \quad (2.64)$$

Where BIL is the Basic Insulation Level of the equipment to be protected $S_A = 1500 \text{ kV}/\mu\text{s}$ and $l = 2.3 \text{ m}$ for the overhead power line on wooded poles while $S_A = 800 \text{ kV}/\mu\text{s}$ and $l = 4.5 \text{ m}$ for the overhead power line with earthed cross arms. Fig.2.31 shown the best method a transformer should be protected in distribution power line using a surge arrester.

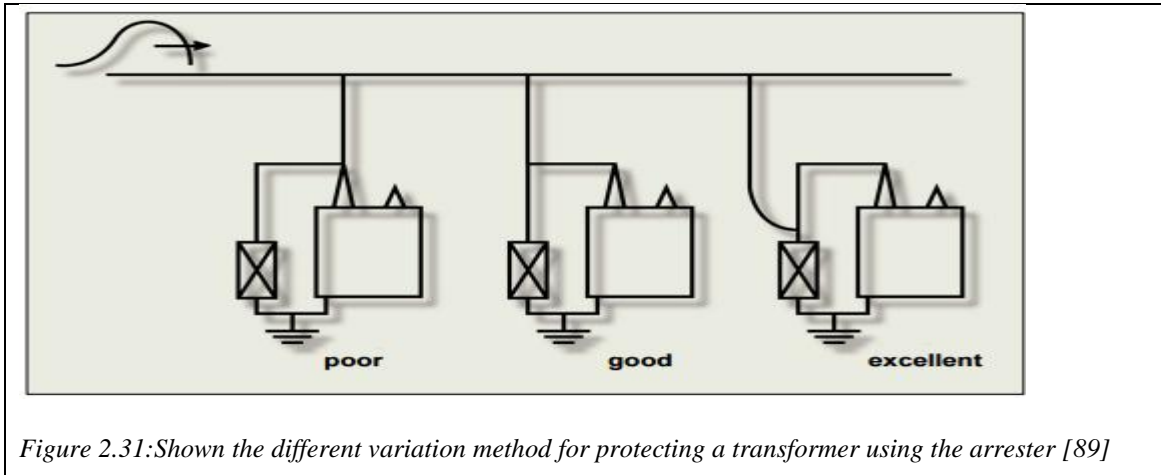

Figure 2.31: Shown the different variation method for protecting a transformer using the arrester [89]

ii) Choosing arrester with low residual voltages

The method of selecting arrester with low residual voltage may increase the insulations capability of the arrester which plays an important role for protecting transformers. The effective values of the residual voltage should less than a half of acceptable transformer BIL i.e.

$$U_p \leq \text{acceptable BIL}/2$$

The maximum arrester current should give by:

$$I_{AM} = \frac{2 \cdot U_1 - U_p}{Z_p} \quad (2.65)$$

Where, U_p is the arrester residual voltage, U_1 is a line insulation level and Z_p , a surge impedance of line (kV).

The protection can be further improved by grounding the cross arms at least last three poles, this will increase the insulation level. The other proposal was to increase transformer BIL level up to 9%. By increasing the transformer BIL level, the protection will increase of 20% but the transformer cost will also increase of 2%. The required transformer will be given by selecting transformer impulse voltages to the HV winding side with respect to low LV

$$V_1 = U_p + R_{ai} \cdot I_{AM} \quad (2.66)$$

and to the LV winding side with respect to transformer tank

$$V_2 = R_{ai} \cdot I_{AM} \quad (2.67)$$

Where R_{ai} , the impulse resistance of arrester earth rod (Ω) and is given by equation (2.64):

$$R_{ai} = \frac{\text{acceptable transf BIL} - U_p}{I_{AM}} \quad (2.68)$$

Fig.2.32 and Fig.2.33 show how a surge current path at the two different installed transformer due to the lightning events. A pad mounted transformer have lower failure rates than a pole mounted

transformer. Pad mount transformer induced voltage passes through the UD cable as shown in Fig.2.33 while a pole mounted is exposure to direct and indirect strike of an overhead lines [90]

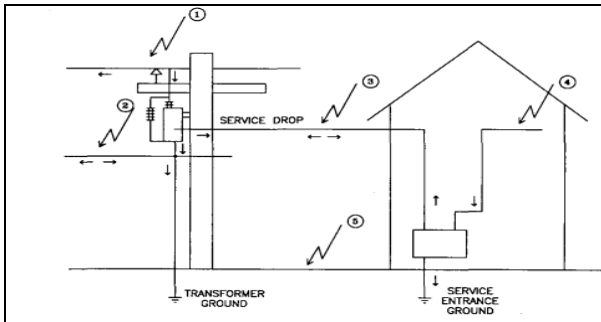

Figure 2.32: Pole mounted transformer

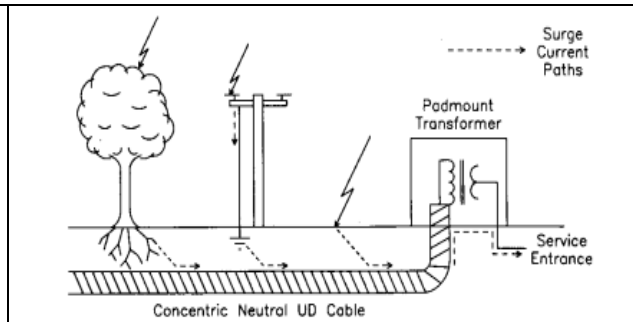

Figure 2.33: Pad mounted transformer

Fig.2.32. 1 is primary phase conductor, 2. the primary neutral conductor, 3. the service drop cable, 4. the load and 5 the earth itself.

For preventing these failures points, a transformer MV (primary side) might protect with a surge arrester but the application of a primary arrester to a distribution transformer does not protect transformer secondary (LV) side and its failures can result from lightning surges on the transformer secondary (LV) side due to low insulation level. The protections of LV transformer side shall be done by applying an additional secondary arrester to the low voltage network [17, 86, 90-97], SPD where exposed sensitive electronic equipment can be damaged and reducing transformer grounding resistance surges [97, 98].

Most of the current will flow down the path with the lowest resistance, then, a service entrance ground may have a lower resistance than the transformer ground [88, 96], This secondary arrester should apply at the transformer secondary side, at the service entrance and also at the load for a balanced condition. The consequently if we apply secondary arrester only at transformer secondary side or at service entrance or at the load will cause damage of that arrester because all surge current will flow through it due to its low impedance and its energy will exceed the capability to withstand. For a balanced surge, the primary surge current will split between the two secondary phase conductors and the secondary neutral so that the maximum current seen by secondary arresters is one third of the primary side discharge current. The secondary arresters at

the transformer and service entrance will be in series for under surge conditions and will both be exposed to these same currents but a surge current applied to the arrester load should be rated higher than that of the secondary transformer arrester nor service entrance to provide some additional protection during unbalanced surges[97].

Note that, arresters should have modelled at both the service entrance and load, as well on both the primary and secondary windings of the distribution transformer as shown in Fig.2.34.

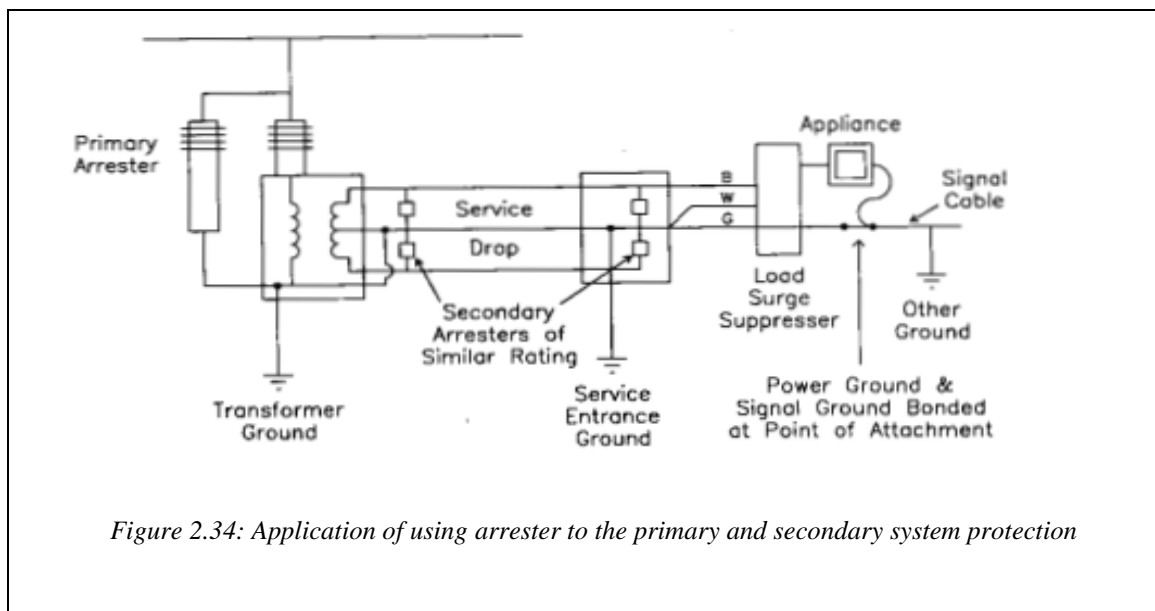

Figure 2.34: Application of using arrester to the primary and secondary system protection

In addition to the transformer protections, the reliability and lifetime of the protector has to be greater than those of the equipment being protected. The protector should be able to continuously protect critical equipment under all abnormal conditions and at all times. There is a new surge protective called Strikesorb that it uses a compressed distribution grade Metal Oxide Varistor proposed by [85] according to their researches and investigations. This Strikesorb was confirmed after the installations of the proposed protection equipment on the sample of 100 transformers, there are zero lightning and surge related transformer failures during the whole period twenty-nine months of investigation while 8.89 transformers without Strikesorb was failures during the same period of investigations. The Strikesorb 40 module have a capability to withstand 140 kA and Strikesorb 80 module can withstand up to 200 kA strikes without degradation. Strikesorb modules are designed to remove 1000 times more thermal energy than conventional SPD[85].

3 Data collections and Method

The thunderstorms were the major cause of power interruptions which was the results for transformers failures of Haugaland Kraft power line distribution networks. The thunderstorms were produced by the environment and seasonal variations. The analysis and improvement of transformers failures due to lightning have based on the data collected from Haugaland Kraft power line distribution network that showing the transformers characteristics and the numbers of transformers failures due to thunderstorms from the years 2009 up to 2015 with relative to the thunderstorms months Fig.4.1 and the data collected from Norwegian Meteorological Institute showing the lightning currents distributions at different yearly seasons in the location of Haugaland Kraft power line distributions networks Fig.3.1.from the years 2009 up to 2013 and 2015 with relative to the thunderstorms period.

3.1 Haugaland Kraft transformer failure data

The transformers failures were installed in different regions of Haugaland Kraft at 770km length of power line distribution network as shown in Fig.3.1 These transformers failures were manufactured from different manufacturers and they had different capacity i.e. 50kVA, 100kVA, 200kVA power distributions and 315kVA with 21kV & 22kV at medium voltage transformer primary side(MV) and 240V at the low voltage transformer secondary side(LV). The Haugaland Kraft power line have an OHGW on Medium Voltage at 500m from the point of transformer installed which help to reduce induced overvoltage from direct lightning strike on power line and the LV side protected by a varistor and low voltage surge arrester. The varistor is used to protect electronic equipment against overvoltages and low voltage arrester used to protect LV side in case of lightning transient disturbances. Even if the transformer was protected in case of lightning transient disturbances, it could failure due to the lightning energy exceed the capability to withstand of power line equipments and protections. Base on the data collected from Haugaland Kraft Power line distribution network and the data from Norwegian Meteorology Institute should help us to know the power line equipment and its protections relative the incidence of lightning current distributions in the region located the power line.

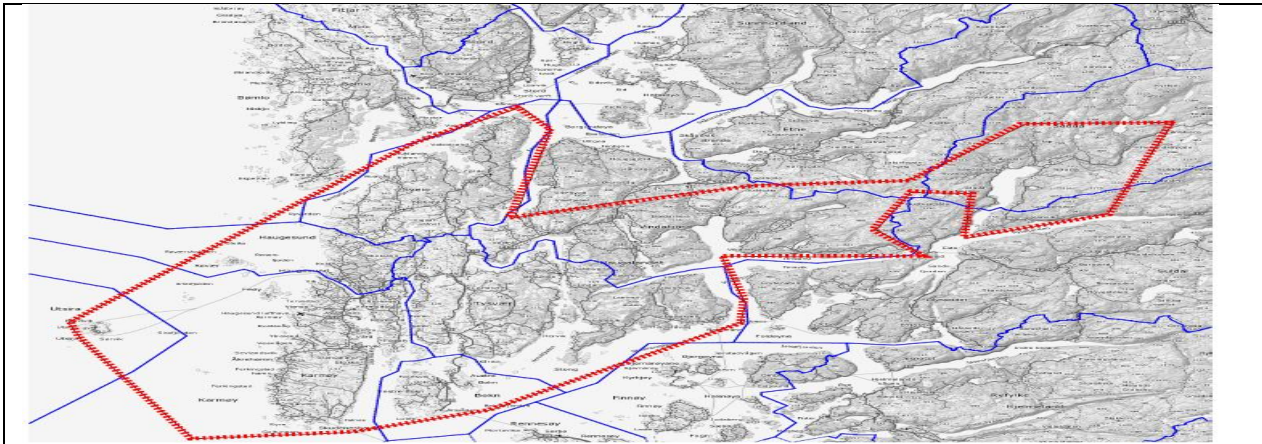

Figure 3.1: Showing the locations (inside of red color) of Haugaland Kraft power line distributions networks.

3.2 Lightning data

We got the lightning data from the Norwegian Meteorological Institute. This lightning data is a part of the European Cooperation for Lightning Detection (EUCLID) network [99]. For the given thunderstorms days, we have only included the data for latitude from 59.0427 to 59.7925 and longitude from 4.7591 to 6.6824 (59.7925, 4.7591; 59.0427, 6.6824) in our analysis. We had only data for Norway and only for some of the days when we have transformer failures Table 3.1.

Table 3.1 demonstrated the available number of thunderstorm days in the region located the Haugaland Kraft power line for some month corresponding to the 6years according to the data from Norwegian Meteorology Institute. The horizontal line represents the yearly months and the vertical line represent the years.

Table 3.1: Showing the provided periods for lightning stroke distributions data from Norwegian Meteorological Institute at the location of Haugaland Kraft power line from 2009 up to 2013 &2015

Years	Months											
	Jan	Feb	Mar	April	May	June	July	Aug	Sept	Oct	Nov	Dec
2009	-	-	-	-	7	-	1014	523	117	-	-	1
2010	-	-	-	-	-	577	-	-	-	-	-	-
2011	-	-	-	-	-	322	-	-	-	-	41	59
2012	17	-	-	-	-	-	161	166	-	37	64	-
2013	-	-	-	-	6	-	232	1718	5054	26	13	65
2015	362	-	-	-	-	-	36	384	15	-	19	3

The collected lightning data would help us in the assessment of environment and seasonal variations for lightning currents distributions at different yearly seasons in the location of Haugaland Kraft power line distributions networks from the years 2009 up to 2013 and 2015 for the period of thunderstorms day. The meteorology data were not covered all day of the lightning stroke and some of uncovered lightning data information Table3.1, there were transformers failures due to thunderstorms according to the data we got from Haugaland Kraft power line Fig.4.1. The uncovered data maybe because of the nature of lightning current or the problem of lightning detection systems. According to Zhu-Ling, 2014 [29], the positive lightning could breakdown due to undetectable at very high frequency radiation location system(VHF) because of their weak very high frequency radiation. These undetectable positive lightning could destroy the transformers in case they strike a power line with the higher number of energy exceed the capability to withstand.

3.3 Data analysis

We have combined lightning data for all six years from 2009 up to 2013 and 2015 Fig.4.4 which should help us for assessing the long term incidence of lightning stroke distributions in the region provided the power line based to the environment and seasons variations and we have also combined the Haugaland Kraft power line transformers failures Fig.4.1 for all seven years from 2009 up to 2015 which should help us to know the period of more transformers failures. The combinations of all data have demonstrate that, the more transformers were failure in the period which had more lightning stroke distributions Fig.4.2 lightning stroke as well as where there were the lightning stroke distributions with higher amplitude Fig.4.5.

4 Results analysis

The results analysis has been base on the data collections information and the different protections method from the different researchers. The Excel and Matlab software were used in the simulations of the results.

4.1 Collected data observations

The distributions of the transformers failures due to the thunderstorms of Haugaland Kraft power line distributions network from 2009 up to 2015 were shown in Fig.4.1. These transformers were damaged due to the incidence of lightning stroke to the power line. The more transformers were damaged in the period of winter where the incidence of positive and negative lightning stroke increase the higher number amplitude Fig.4.5.

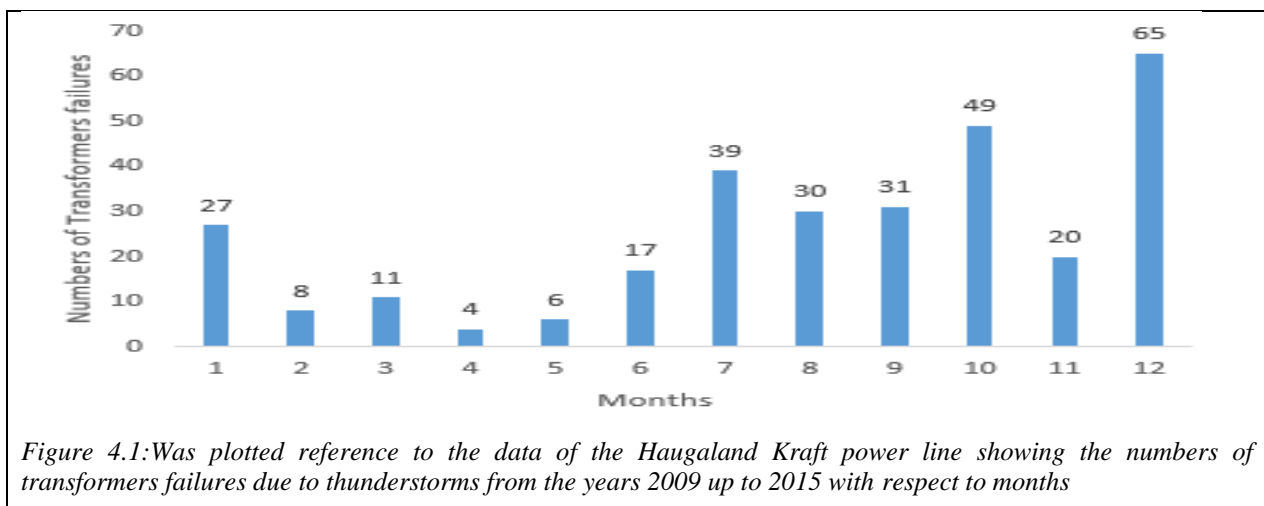

The distribution numbers of lightning stroke in the location of Haugaland Kraft to the power line distribution networks for six years from 2009 up to 2013 & 2015 was shown in Fig.4.2, then, where we found zero means that they were no Meteorological lightning data provided as explained in Table 3.1. The Fig.4.2 shown that there was more lightning stroke in the yearly months of June up to September. These more lightning stroke Fig.4.2 & Fig.4.4 could cause transformers failures as shown in Fig.4.1. Even the few lightning stroke in yearly months of October, November, December, January and May cause transformers failures Fig.4.2 depend on the capability of the power line to withstand due to the transient disturbances.

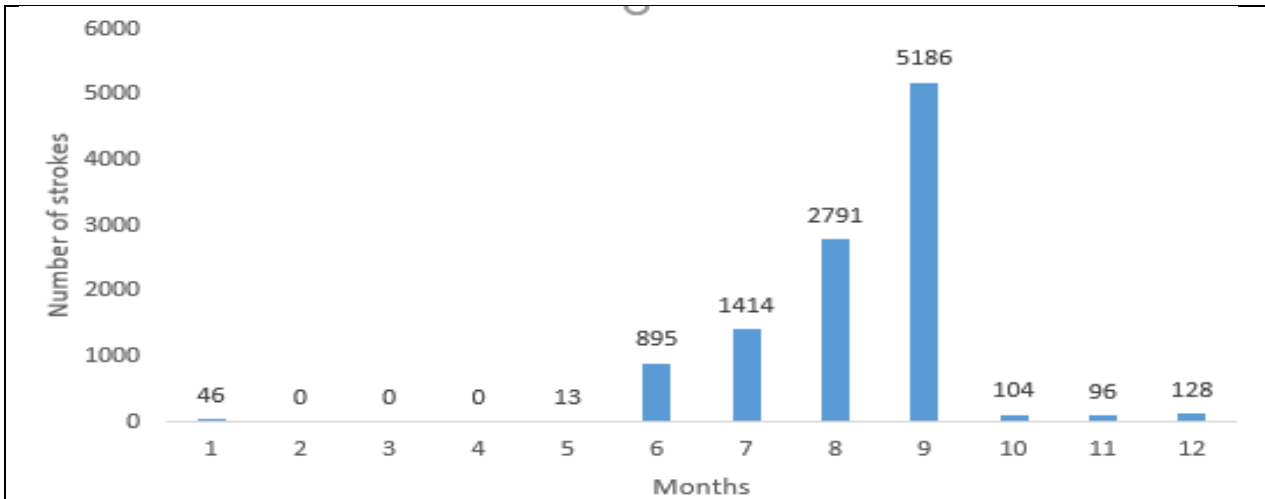

Figure 4.2: Showing the number of lightning stroke in the location of Haugaland Kraft power line from 2009 up to 2013 & 2015 relative to the yearly months

The transformers failures Fig.4.1 depend on the positive and negative lightning current charges Fig.4.3. induced on power line with respect to the power line equipments and protections withstand capability. Fig.4.3. showing the transformers failures caused by the small amplitude values Fig.4.5 of the lightning strike in June up to September. These small amplitude values of the lightning current cause transformers failures Fig.4.1 due to the higher numbers of lightning stroke distributed on the power line Fig.4.2. The higher numbers of transformers failures in January, May, October and December Fig.4.1 & Fig.4.3 could depend on the higher amplitude values of lightning stroke Fig.4.5 with few numbers of the strike Fig.4.2.

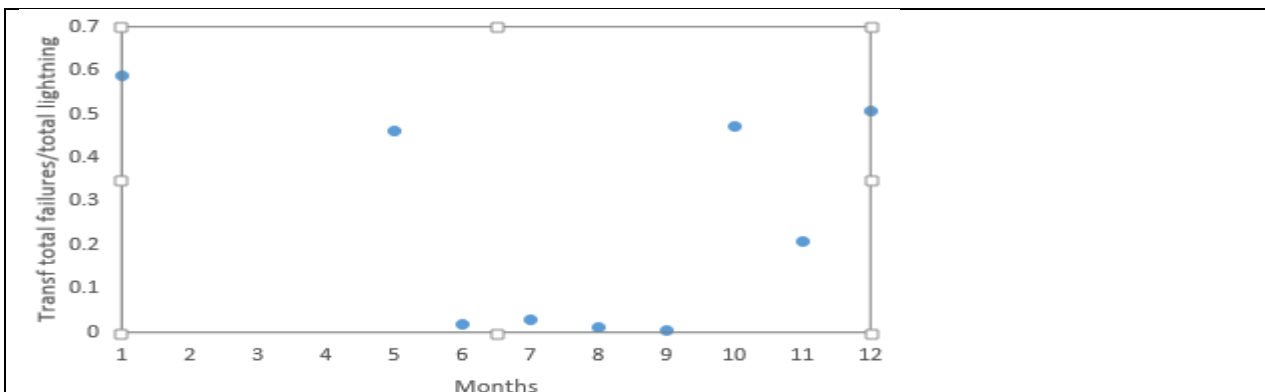

Figure 4.3: Transformers failures due to the lightning peak current distributions in the Haugaland Kraft power line as function of Months

In the observations of Fig.4.4 showing that there were more positive and negative lightning distributions for the whole period of six years but more lightning current with small amplitude between -30 and 40kA. The distributions of positive lightning current had higher amplitude values than the distributions of the negative lightning.

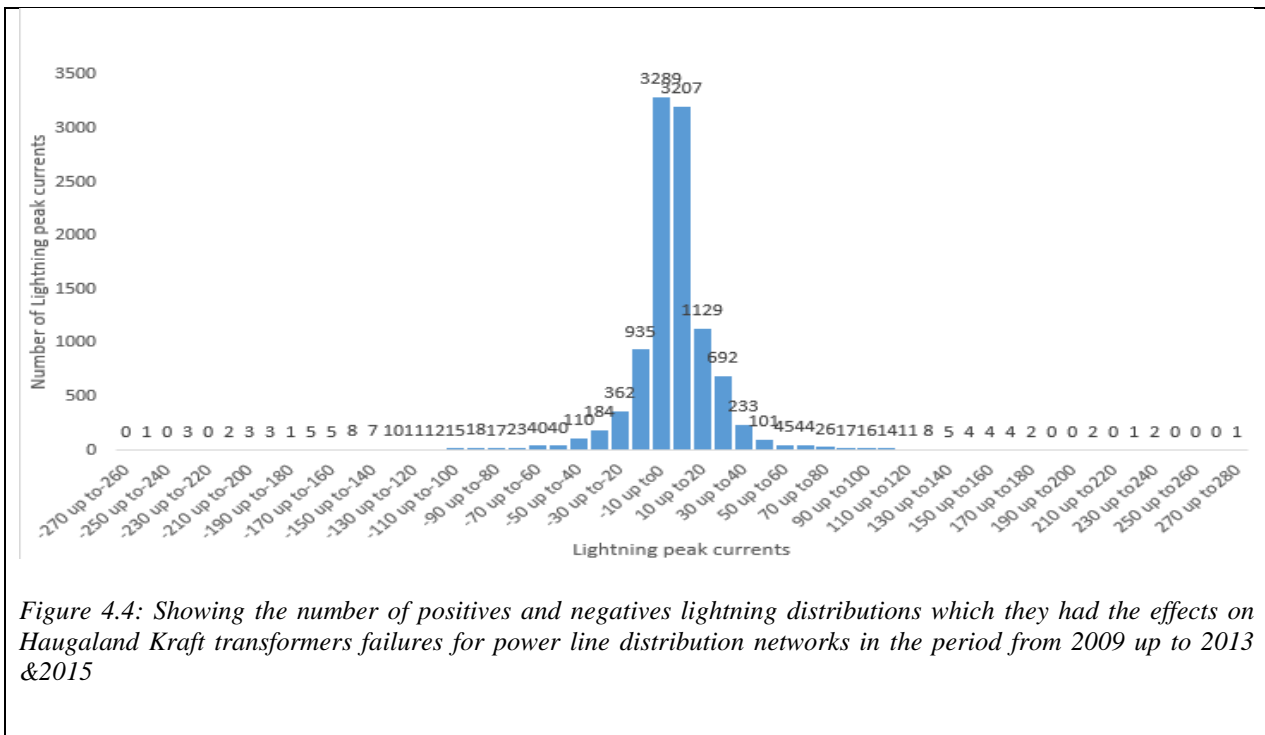
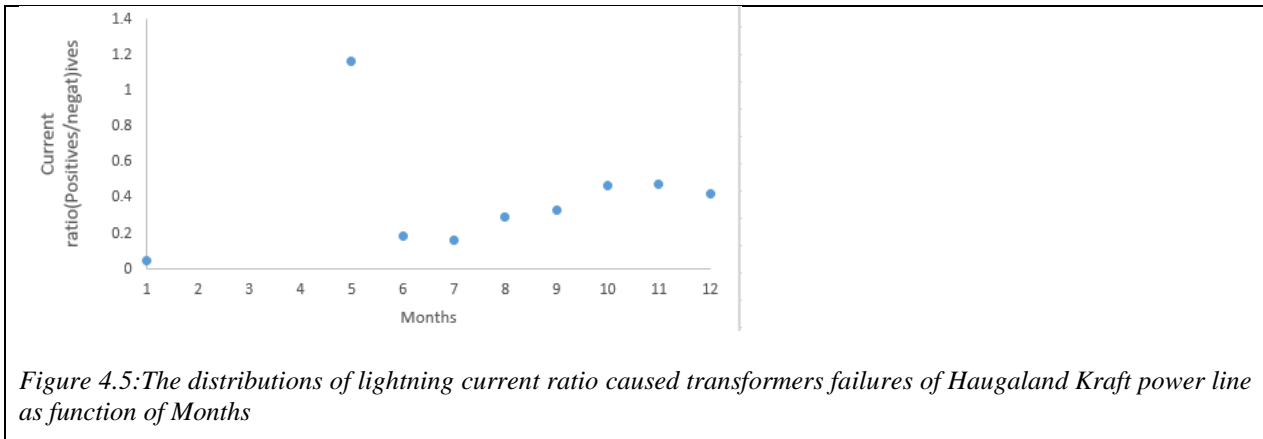

Figure 4.4: Showing the number of positives and negatives lightning distributions which they had the effects on Haugaland Kraft transformers failures for power line distribution networks in the period from 2009 up to 2013 & 2015

The distributions lightning ratio and average lightning current as function of yearly months provided during the period of the years from 2009 up 2013 & 2015 are shown in Fig.4.5 and Fig.4.6 respectively. The Fig.4.5. showing there were more negative and more positive lightning distribution stroke in the whole yearly months but in May had more positive lightning than negative Fig.4.5 with higher amplitude values Fig.4.6 and from February up to April no data provided from them as explained in Table 3.1. In January, it had also more negative lightning than positive lightning Fig.4.5 with higher amplitude Fig.4.6. All these lightning distributions could damage the transformers Fig.4.1.



The average distributions of lightning stroke in the yearly months of October, November, December and January had higher amplitude values Fig.4.6. In the observation of Fig.4.6 shown that, the incidence of lighting strokes with higher amplitude values in the Haugaland Kraft power line increases during the winter time which is the same as according to [31] but differ from what I found in [11] and in the summer period there were more lightning strike with small amplitude values. In this period, there will be more positive and negative lightning strike. In the winter time, there would be the development of more positive and negative lightning strike. According to this observations, the power line equipments and its protections should base on the lightning data in the region located the power line not on the whole country or continental. The error bars Fig.4.6 was calculated as one standard deviation of the peak current for each Month.

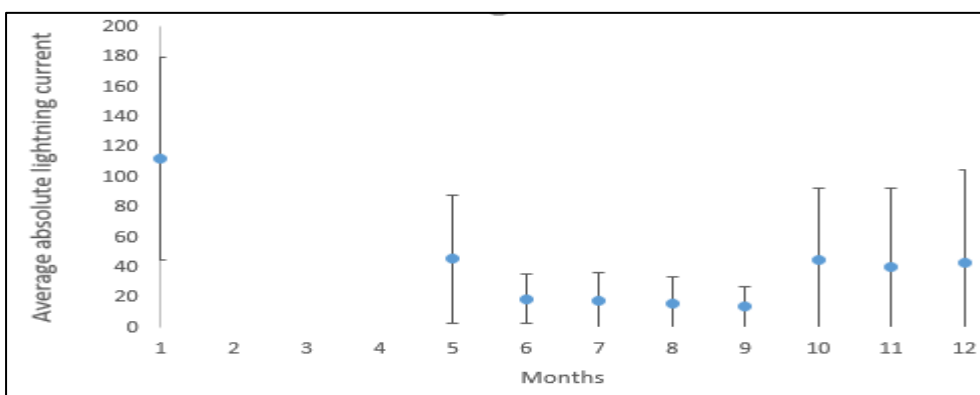

Figure 4.6: Average absolute lightning peak current provided in thunderstorms in the Haugaland Kraft power line as function of Months cause transformers failures

4.2 Results from the literature review

The Haugaland Kraft transformers could damage in case of direct and indirect lightning strike but it could be prevented by taking into account the main parameters of the power line distribution

network which could increase or decrease the lightning induced overvoltages, the power line equipments capacity as well as the standard protections. The distributions transformers should be well protected against lightning strike depending on the power line capability to withstand. The study was based on Low voltage and Medium Voltage. The classifications of the electrical power industry, the LV is less than 1kV and the Medium Voltage (Distribution) is between 1kV and to about 33 kV[100].

4.2.1 The main parameters for preventing transformers failures due to lightning effects

The lightning induced overvoltage by direct strike to or nearby the grounded power line should depending on the capacity of lightning peak current. When lightning strike with higher or lower amplitude, it will induce energy in the power line distribution network which can cause a transformer failure. The transformers connected directly to the phase conductor through the surge arrester, all transient disturbances will be directly on the surge arrester and the most probability of transformer failures is in case of surge arrester failure to withstand energy capability. The induced lightning energy could be avoided by considering the following parameters: (1) Lightning current, (2) Grounding resistance, (3) Soil resistivity, (4) Striking interval distance from an object to the grounded power line, (5) Tower height, (6) Line length, (7) Ground flash density, (8) Shield wire height (9) Span length and (10) OHGW.

The simulations are performed in Excel and in MATLAB by using the parameters of the distribution power line in Table4.1; the ground flash density $N_g = 0.1 \text{ flash} / \text{km}^2 / \text{year}$ by considering the environment and seasonal variation of the Norway by referring to the data from ATDnet, 2014 [11] and the absolute average and maximum lightning current available in the location of Haugaland Kraft power line distribution network. The absolute average lightning current was 17kV and the absolute maximum lightning current was 267kA. The absolute average lightning current could help to find the average induced overvoltage and the outage in the power line while the maximum absolute lightning current could help to find the maximum induced overvoltages and outage in the power line. The maximum lightning current could induce more outages and higher energy in the power line which we can take it into account in designing the power lines equipments.

Table 4.1: Showing the power line and lightning parameters

cross arm height, m	phase conductor height, m	phase conductor separation, m	shield wire height, m	shield wire separation distance, m	Tower height, m	Channel surge impedance, Ω
9.72	10	3.66	13.05	3.66	13.05	450
span length, m	tower surge impedance, Ω m	tower-footing resistance, Ω	power line surge impedance, Ω	correlation coefficient	cross-arm width, m	Return stroke current, kA
100	100	10 and 40	450	0.47	2	1-300kA

The induced voltage when lightning strokes to the tower for unshielded power line was simulated from equation (2.15) as shown in Fig (4.7 and 4.8). The results shown that the induced voltage in the power is proportional to the lightning current. It was increase by lightning current increase and it was decrease by decrease the tower footing resistance.

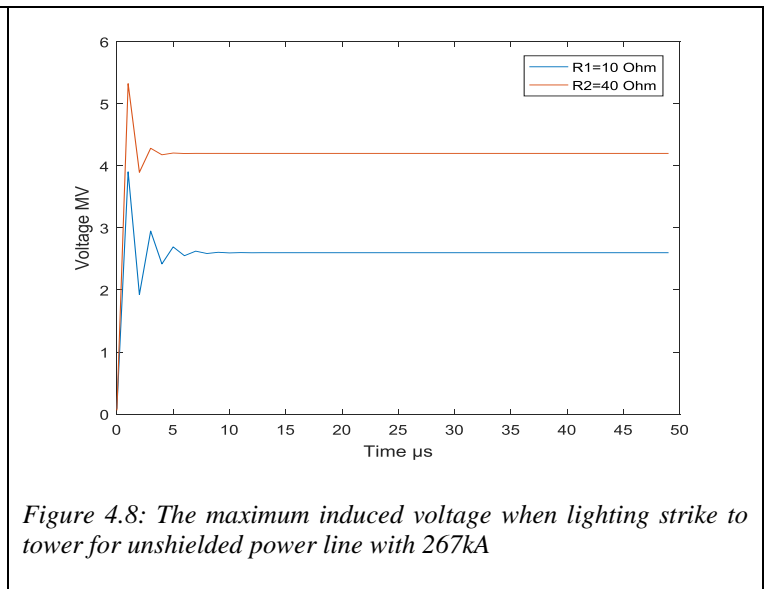
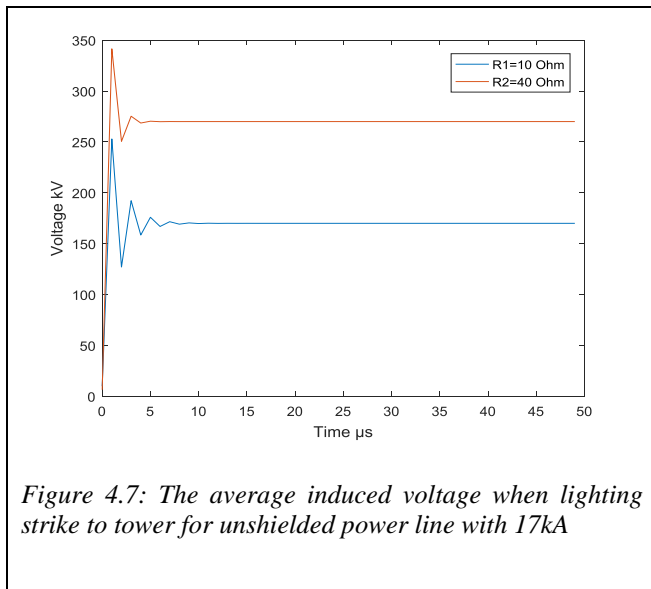

When the lightning strokes to the phase conductor for unshielded power line was simulated in Fig (4.9 and 4.10) from equation (2.11). The results shown that, the induced voltage will increase with lightning current increase.

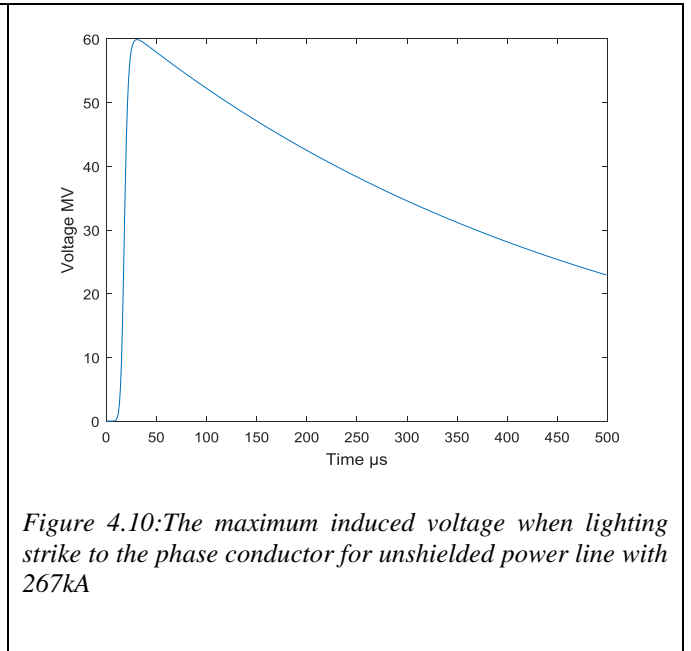
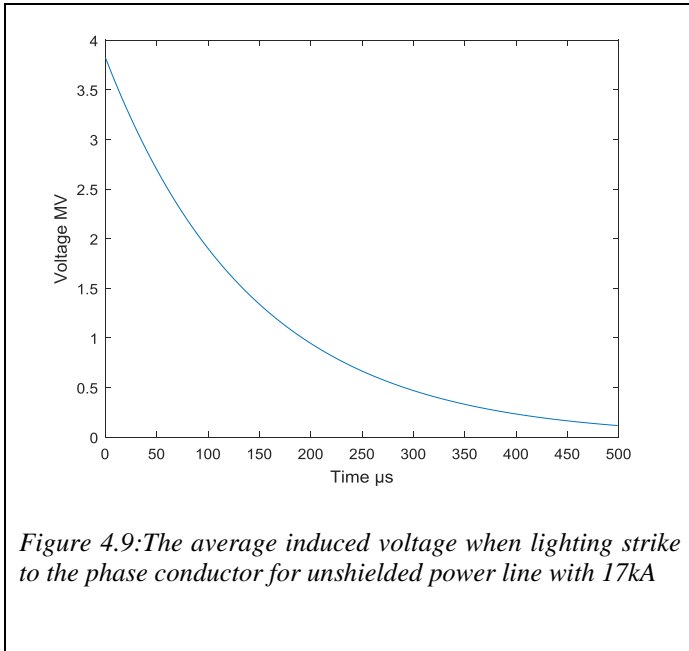

When lightning strike to the shielded power line, the induced voltage will decrease in comparison with unshielded power line. The simulated results are in the Fig (4.11 and Fig.4.12) from equation (2.18).

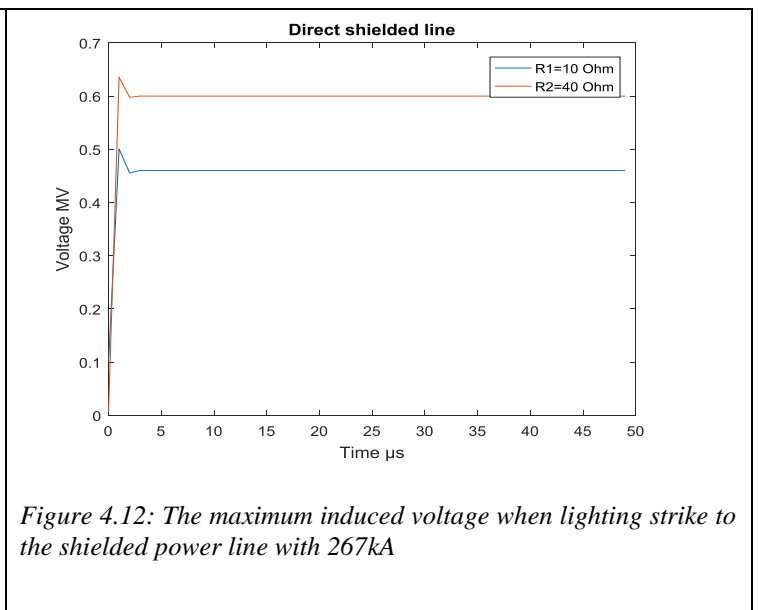
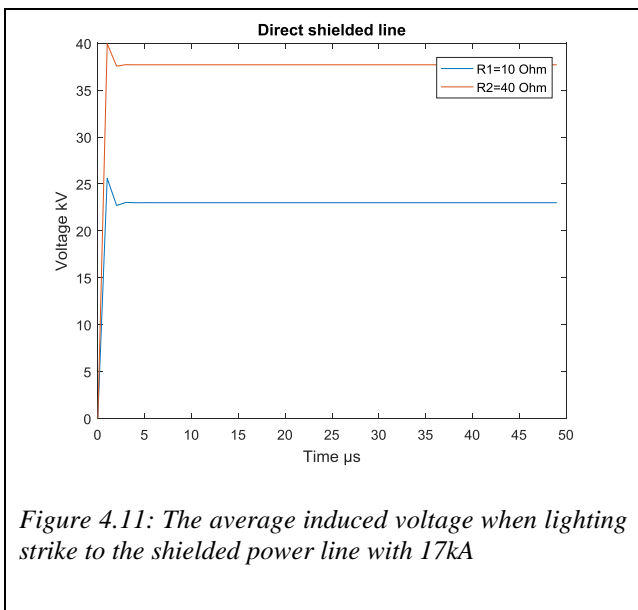

The induced overvoltages in the power line distribution network in case of direct strike should very high. For these stroke to the phase conductors as shown in Fig.4.9 and Fig.4.10 had higher amplitude lightning current. These overvoltages could stress insulators and they could decrease

using overhead ground wire and by taking the small tower footing resistance as shown in the Fig.4.7,4.8,4.11 and Fig.4.12. All these overvoltages caused by direct stroke to the power line could destroy the transformer without taking account into the BIL equipment and the standard lightning protections because of their higher overvoltages amplitude values.

The induced voltage when lightning strike to the object nearby a grounded power line was simulated in Fig (4.13 up to 4.18) from equation (2.26).

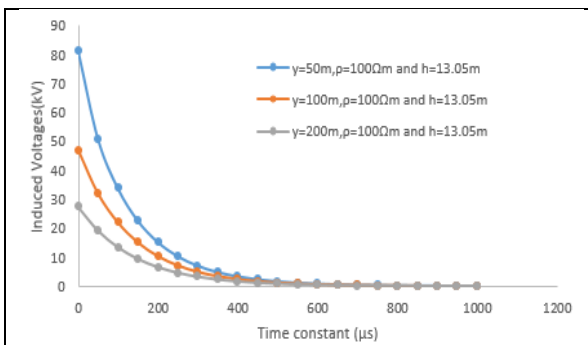

Figure 4.13: The average induced voltage when lightning strike nearby grounded power line with 17kA by considering the distance between power line and striking object

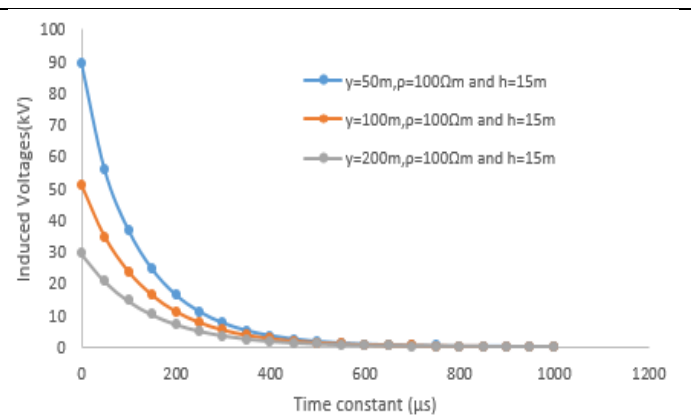

Figure 4.14: The average induced voltage when lightning strike nearby grounded power line with 17kA by increase the tower height.

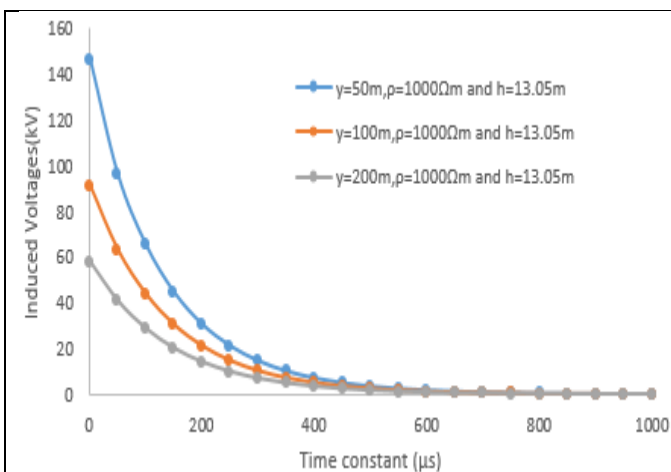

Figure 4.15: The average induced voltage when lightning strike nearby grounded power line with 17kA by increase the soil resistivity.

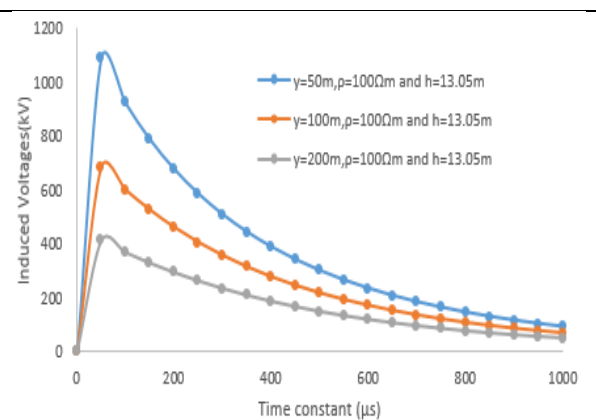

Figure 4.16: The maximum induced voltage when lightning strike nearby grounded power line with 267kA by considering the distance between power line and striking object

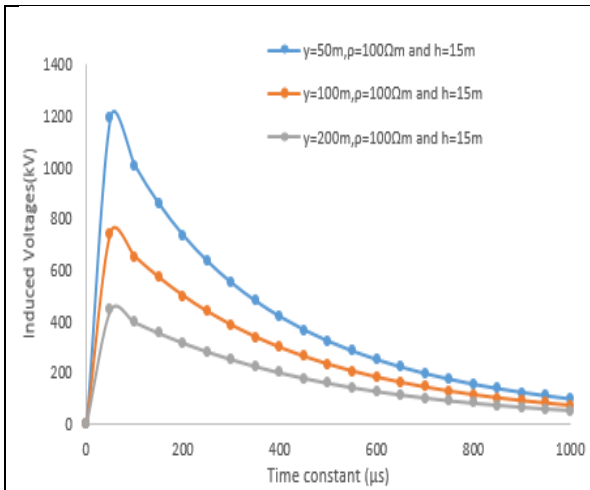

Figure 4.17: The maximum induced voltage when lightning strike nearby grounded power line with 267kA by increase the tower height.

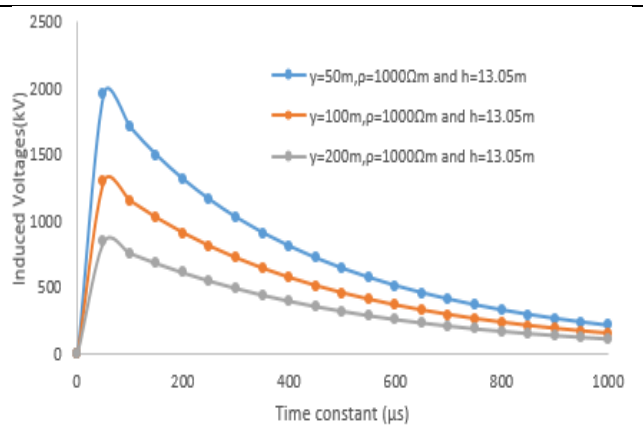

Figure 4.18: The maximum induced voltage when lightning strike nearby grounded power line with 267kA by increase the soil resistivity.

The results shown in Fig.4.13 up to Fig 4.18 was plotted by taking account into the tower height, soil resistivity and the interval distance between a grounded power line and stroke tall object. When the tower height and the soil resistivity increase, the induced overvoltages will increase i.e. they are in proportional with the lightning currents. The interval distance between the power line and the tall structure play an important role in constructing the power line. They will induce more overvoltages when stroke nearby the tall object while it will decrease when stroke far from the tall objects.

The outage rate caused by the direct lightning strike to the power line was simulated in Fig (4.19 up to 4.24) for unshielded power line from equation (2.41) and for shielded power line from equation (2.42).

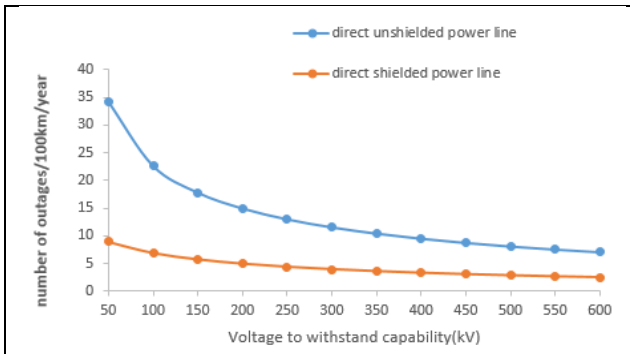

Figure 4.19: The outage rate due to direct strike for unshielded and shielded power line with the average lightning current of 17kA at 100m span length with 100km line length.

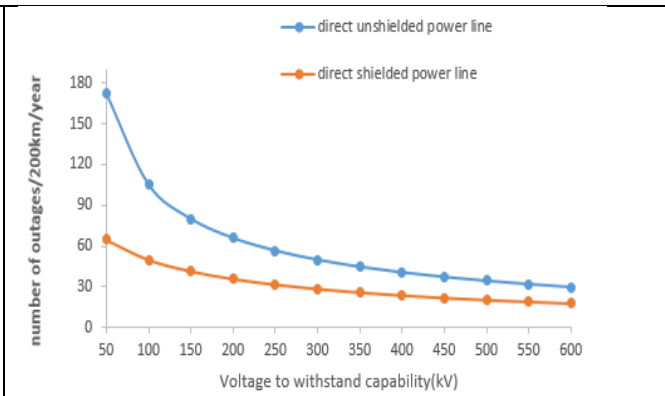

Figure 4.20: The outage rate due to direct strike for unshielded and shielded power line with the average lightning current of 17kA at 100m span length with 200km line length

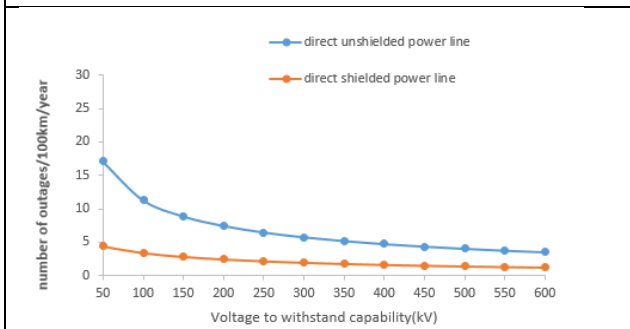

Figure 4.21: The outage rate due to direct strike for unshielded and shielded power line with the average lightning current 17kA at 200m span length

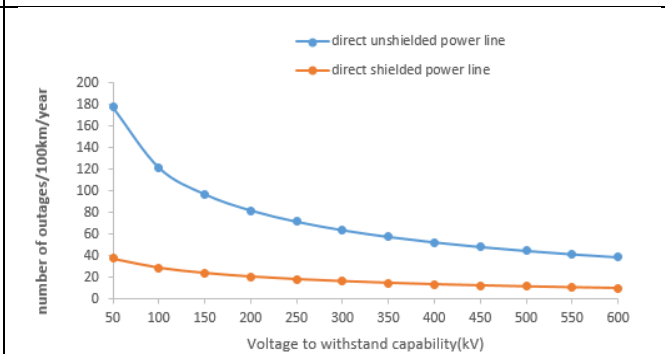

Figure 4.22: The outage rate due to direct strike for unshielded and shielded power line with the maximum lightning current 267kA at 100m span length

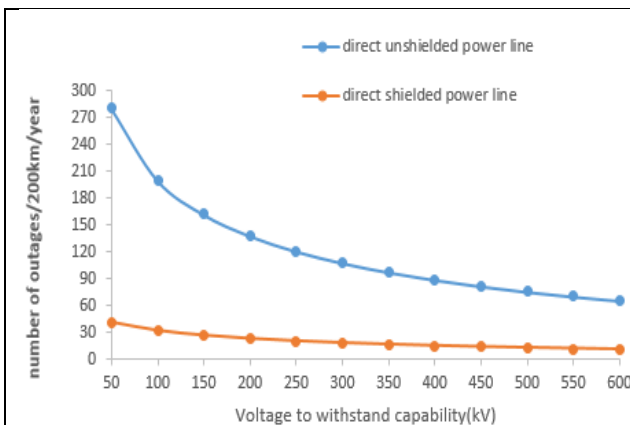

Figure 4.23: The outage rate due to direct strike for unshielded and shielded power line with maximum lightning current 267kA at 100m span length

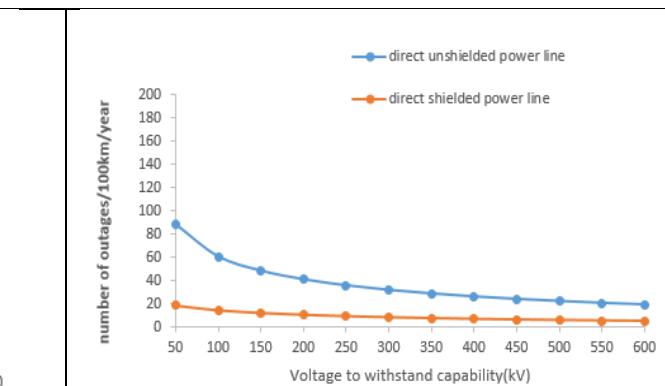

Figure 4.24: The outage rate due to direct strike for unshielded and shielded power line with maximum lightning current 267kA at 200m span length

The outages rate caused by direct strike to the power line would decrease by increasing the span length. Most of the time the lightning strike to the tall object, in that case the stroke to tower could have more outage in the power line than stroke to the phase conductor. The short span length had more tower than the longer one with the same power line length i.e. the more numbers of tower define the more outage Fig.19 and Fig.4.22. and the few number of tower define the few outage Fig.4.21 and Fig.24.in the power line. By considering the line length, the outage rate is proportional to the line length as the line length become larger the more outage Fig. 4. 20. And Fig.4.23. and when it became shorter there would be few outage Fig.4.19 and Fig.4.22.

There was also the outage rate caused by lightning when strike to the object nearby a grounded power line which are shown in Fig (4.25 and Fig.4.26) from equation (2.43).

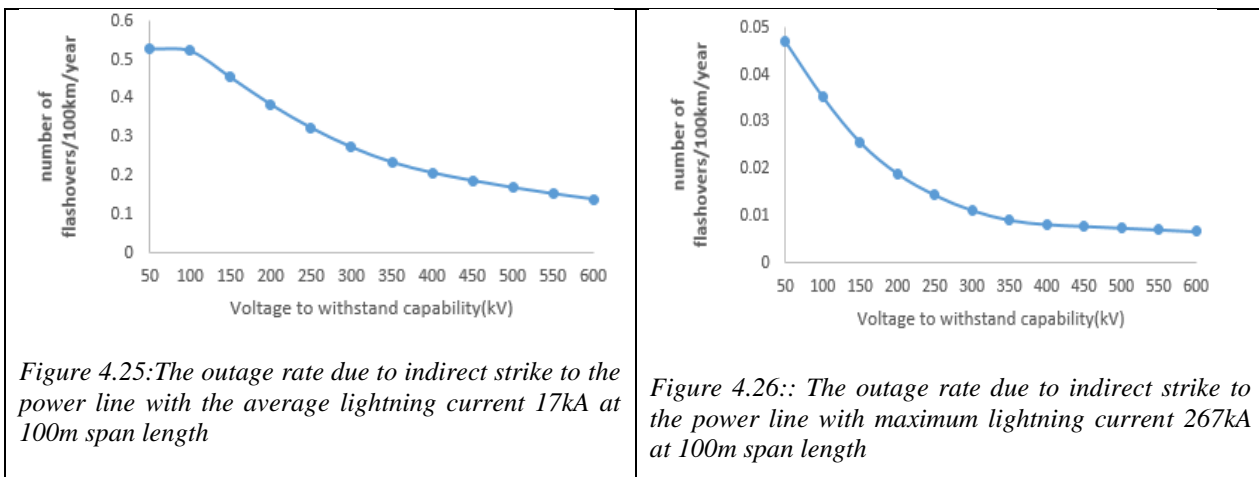

Figure 4.25: The outage rate due to indirect strike to the power line with the average lightning current 17kA at 100m span length

Figure 4.26: The outage rate due to indirect strike to the power line with maximum lightning current 267kA at 100m span length

From all these simulated results was based to the protection of the power line equipments such as the transformer. The transient disturbances in the power line are directly proportional to the transformer because it connected to the phase conductor through the surge arrester. The failure the power line insulator and surge arrester cause transformer failures. The direct strike to the power line induced more overvoltages than the indirect effect. Even the outage rates cause by the direct effect had more outages than indirect effect by referring to the simulated results.

5 Discussion

Transformers' protection during thunderstorms based on literatures

The improvement performance of the transformer protections was done by protecting the power line by installing the OGW by protecting the direct strike to the phase conductors which is connected directly to the transformer. The surge arrester is also another type of material used to protect the transformers. It plays the main important role in protections of the direct and indirect lightning strike as shown in Fig (2.26) but it can fail due to the higher energy of the lightning stroke exceed the capability to withstand. To improve the performance of the arrester and the power line insulations for protecting the transformer, we should install the OGW. The arrester spacing also cause the failures, results for the transformer failure, it will improve by installing the surge arrester at least 200m apart. The spacing distance between arrester and transformer also is another cause of transformer failure and power outage.

The separations distance between transformer and surge arrester should be considered with reference to the equations (2.58 and 2.64). The power line equipment lifetime could cause the transformer failure. The materials used to protect the transformer should have the life time greater than the equipment to be protected. The small life time of the power line equipment decrease the capability to withstand in case of transient disturbances. With reference to the simulated results, the induced overvoltage in the Haugaland Kraft power line had the higher amplitude value i.e. the power line equipment with higher capacity to withstand in case of transient disturbances i.e. with the designed BIL level are required. The selection of the arrester residual voltage is another advantage for improving the transformer protection which will increase the withstand capacity of the transformer.

Transformers' protection during thunderstorms based on simulation results

The higher number of transformers of the Haugaland Kraft power line distribution network were damaged in the winter period as shown in Fig.4.1. because at this time the distribution of lightning current stroke with the higher positive and negative amplitude values as shown in Fig.4.5. With reference to the simulated results is subchapter 4.1, all the simulated figures show that the induced overvoltage increase as the lightning current increases. The direct strike to the power line had more effect than the indirect effect as shown in the simulated results. When the lightning stroke

direct to the object, it will induce the higher energy in the struck object than to induced overvoltages caused by indirect stroke.

In the analysis of the simulated results, the tower footing resistance plays an important role in the power line to decrease the induced overvoltages by taking in account the small number as possible as described in Fig.4.7,4.8,4.11 and 4.12. The OGW wire also plays an important role to decrease the induced overvoltage caused by the direct lightning as shown in Fig.4.11 and Fig.4.12. In addition, OGW increases the capacity for power line insulations and surge arrester. The interval distance between the grounded power line and the tall structure or object should be as long as possible in order to reduce the induced overvoltages caused by indirect strike as described in Fig. 4.13 and Fig.4.16. The tower height used in the power line should be designed according to the standard values because when it became tall, it will increase the induced voltage in the power line in case of lightning strike as shown in Fig. 4.14 and Fig.4.17. High soil resistivity increases the lightning induced overvoltage in the power line as shown in Fig.4.15 and Fig.4.18. Minimizing the soil resistivity will lead to a reduced lightning induced overvoltage in the power line, hence the protection of the transformer.

Outage rate in the power line increases directly proportional to the power line length and inversely proportional to the span length as shown from Fig.4.19 to Fig.24 due to direct strike. Shorter span length has more outages than long span length for the same power line length. Shorter span contains more towers and they are attractive to lightning due to their tallness. Direct strike cause more outage rate than indirect strike as shown in Fig.4.25 and Fig.4.26. This is because when a direct lightning strike directly to the power line, it induces more energy which can exceed the equipment capacity of power line. This results in the transformer failure or damage hence outage rate.

6 Conclusion and Recommendations

The improvement transformer protection was carried out by taking into account the tower footing resistance, the installations of shield wire, the power line equipment BIL level and installation of lightning arresters. This is accomplished by taking into account the interval distance between arresters which give a significant outages reduction of the distribution power lines in the region. According to the Fig.4.4, the distributions lightning current have more lightning distributions in the Haugaland Kraft power line. These distribution lightning current cause transformer failures which is very expensive and difficult to repair.

The designed power line equipment should be designed base on the environment and seasonal variations of the region the power line is located. According to the NVE report, 2011 [19], it demonstrates that the lighting frequency or the lightning incidents and thunderstorms will increase about 25% towards 2050, with an uncertainty range from 0 to 50% increase by expecting further increase until the year 2100. This shows that there is a need to pay attention on the protection of the power line by increasing the capacity of the equipment with respect to the standard protections as well as taking account into the parameters which will help to improve the performance of the power line.

The analysis of transformer failures in the power line distribution plays an important role. This can be fulfilled by taking account into the electrical power energy which is needed by the industrial, private sector, government sector and human being in everyday life. This is more crucial especially in the winter period where power is needed for domestic use. The power outage for long time could cause many problems to human life and to the development of country. In general, most of the equipment need the power supply in their working time.

Preventing transformers against damage is one of the main focus for this project. The transformers are protected by the use of surge arresters, OGW, consideration of ground and soil resistivity, distance between grounded power line and taller objects and the interval distance between arrester and transformers. In addition, transformer can be protected by the use of Strikesorb surge protective equipment. Protecting the transformers will prevent blackout to customers and decreasing the maintenance cost caused by lightning strikes. When the transformer is protected,

the power line will be stable hence the whole system stability and the equipments life time will increase.

Future work

Transformer protection increases the lifetime of the power line equipments. In order for the transformer to be protected, there are measures that need to be implemented which include the analysis of parameters included in the lightning strike prevention. Due to time and lack of dedicated software tools, we did not analyze the parameter using Electromagnetic software program analyzer rather we used Matlab which not a specialized software to analyze transient disturbance. This will be done in future work in order to prevent the transformers against the lightning strike by analyzing the transient disturbances using a specialized software.

7 References

- [1] (2006). www.cronallweather.co.uk/images/Lightning-Diagram.jpg.
- [2] E. E. Co. (2014). europowerkiosk.com/images/portfolio/kiosk_01.jpg.
- [3] P. Chowdhuri, "Power System Transients," 2001.
- [4] V. Cooray, *An Introduction to Lightning*: Springer, 2015.
- [5] L. L. Grigsby, *The electric power engineering handbook*: CRC Press, 2001.
- [6] Q. INTERNATIONAL. (1982).
www.visualdictionaryonline.com/images/energy/hydroelectricity/electricity-transmission/overhead-connection.jpg.
- [7] M. V. B. U.A.Bakshi, "Power system-II(Switchgear and Protection) ", ed. Pune, India: Technical Publication Pune, 2009.
- [8] V. Cooray and M. Fernando, "Lightning parameters of engineering interest," *Lightning Protection*, 2009.
- [9] S. Yokoyama, T. Sato, and A. Takahashi, "Practical lightning protection design for overhead power distribution lines," in *2014 International Conference on Lightning Protection (ICLP)*, 2014.
- [10] V. A. Rakov and M. A. Uman, *Lightning: physics and effects*: Cambridge University Press, 2003.
- [11] G. Anderson and D. Klugmann, "A European lightning density analysis using 5 years of ATDnet data," *Nat. Hazards Earth Syst. Sci*, vol. 14, pp. 815-829, 2014.
- [12] S. Yokoyama, "Lightning protection of overhead power distribution lines," *IEEE Transactions on Electrical and Electronic Engineering*, vol. 2, pp. 491-496, 2007.
- [13] J. Paulino, C. Barbosa, I. Lopes, and W. Boaventura, "Assessment and analysis of indirect lightning performance of overhead lines," *Electric Power Systems Research*, vol. 118, pp. 55-61, 2015.
- [14] H. J. Christian, R. J. Blakeslee, D. J. Boccippio, W. L. Boeck, D. E. Buechler, K. T. Driscoll, et al., "Global frequency and distribution of lightning as observed from space by the Optical Transient Detector," *Journal of Geophysical Research: Atmospheres*, vol. 108, 2003.
- [15] L. Van Der Sluis, *Transients in power systems*: Wiley, 2001.
- [16] P. Chowdhuri, S. Li, and P. Yan, "Rigorous analysis of back-flashover outages caused by direct lightning strokes to overhead power lines," in *Generation, Transmission and Distribution, IEE Proceedings-*, 2002, pp. 58-65.
- [17] A. Piantini, "Lightning protection of overhead power distribution lines," in *29th International Conference on Lightning Protection*, Uppsala, Sweden, 2008, pp. 1-29.
- [18] J. Lucas and D. Nanayakkara, "Lightning protection of pole-mounted transformers and its applications in Sri Lanka," *Transactions of the IEE Sri Lanka*, 2001.
- [19] H. B. Stranden and H. A. Grønsten, "Evaluering av måledata for snø, sesongene 2009/2010 og 2010/2011," *NVE Rep*, pp. 23-2011, 2011.

- [20] A. van Delden, "The synoptic setting of thunderstorms in western Europe," *Atmospheric research*, vol. 56, pp. 89-110, 2001.
- [21] Z. Levin, W. J. Borucki, and O. B. Toon, "Lightning generation in planetary atmospheres," *Icarus*, vol. 56, pp. 80-115, 1983.
- [22] K. Mezuman, C. Price, and E. Galanti, "On the spatial and temporal distribution of global thunderstorm cells," *Environmental Research Letters*, vol. 9, p. 124023, 2014.
- [23] J. Ribič, "Impact of line length on the operation of overvoltage protection in LV networks," *Electric Power Systems Research*, vol. 121, pp. 216-226, 2015.
- [24] D. Abdelhakim, H. Ali, and D. Djalel, "Establishment of the Security Apparatus against Damage Caused by Lightning on a Transmission line of Electrical Energy," *Physics Procedia*, vol. 55, pp. 215-219, 2014.
- [25] Ł. Staszewski, "Lightning Phenomenon—Introduction and Basic Information to Understand the Power of Nature," in *International Conference Environment and Electrical Engineering*, 2010.
- [26] J. R. Dwyer and M. A. Uman, "The physics of lightning," *Physics Reports*, vol. 534, pp. 147-241, 2014.
- [27] D. Rodriguez-Sanabria, C. Ramos-Robles, and L. Orama-Exclusa, "Lightning and Lightning Arrester Simulation in Electrical Power Distribution Systems," *Electrical and Computer Engineering: University of Puerto Rico* [online], 2005.
- [28] S. USA. www.skyscanusa.com/wp-content/uploads/2012/01/lightning-develops.jpg.
- [29] S. Zhu-Ling, Q. Xiu-Shu, and L. Ming-Yuan, "Characteristics of a negative cloud-to-ground lightning discharge based on locations of VHF radiation sources," *Atmospheric and Oceanic Science Letters*, vol. 7, pp. 248-253, 2014.
- [30] P. Chowdhuri, J. Anderson, W. Chisholm, T. Field, M. Ishii, J. Martinez, et al., "Parameters of lightning strokes: a review," *Power Delivery, IEEE Transactions on*, vol. 20, pp. 346-358, 2005.
- [31] S. Pédeboy and W. Schulz, "Validation of a ground strike point identification algorithm based on ground truth data," in *Proceedings, International Lightning Detection Conference ILDC*, 2014.
- [32] Y. Zhou, A. Pahwa, and S.-S. Yang, "Modeling weather-related failures of overhead distribution lines," *Power Systems, IEEE Transactions on*, vol. 21, pp. 1683-1690, 2006.
- [33] I. K. LEVEL, "Lightning Flash and strike-point Density in Belgium."
- [34] C. Bouquegneau, "The Need for an International Standard on Lightning Location Systems," in *23 rd International Lightning Detection Conference*, Tucson, Arizona, USA, 2014.
- [35] L. L. Grigsby, "Power Systems, Third Edition," ed. New York: CRC Press, 2012, p. 18.
- [36] C. Bouquegneau, "Lightning density based on lightning location systems," in *Lightning Protection (ICLP), 2014 International Conference o*, 2014, pp. 1947-1951.
- [37] D. Diendorfer and W. Schulz, "Ground flash density and lightning exposure of power transmission lines," in *Power Tech Conference Proceedings, 2003 IEEE Bologna*, 2003, p. 3 pp. Vol. 3.

- [38] A. Popov, "Instrument for detection and registration of electrical fluctuations," *Journal of Russian Physics and Chemistry Society*, vol. 28, pp. 1-14, 1896.
- [39] A. Nag, M. J. Murphy, W. Schulz, and K. L. Cummins, "Lightning locating systems: Insights on characteristics and validation techniques," *Earth and Space Science*, vol. 2, pp. 65-93, 2015.
- [40] S. Tang, G. Wu, and H. Yin, "Study of Ground Flash Density," in *Power System Technology, 2006. PowerCon 2006. International Conference on*, 2006, pp. 1-3.
- [41] R. Anderson, A. Eriksson, H. Kroninger, D. Meal, and M. Smith, "Lightning and thunderstorm parameters, paper presented at International Conference on Lightning and Power Systems, Inst. of Electr. and Electron," Eng., London, UK, 1984.
- [42] D. MacGorman, M. W. Maier, and W. Rust, "Lightning strike density for the contiguous United States from thunderstorm duration records," *National Oceanic and Atmospheric Administration, Norman, OK (USA). National Severe Storms Lab*.1984.
- [43] M. Paolone, F. Rachidi-Haeri, and C. A. Nucci, "IEEE Guide for Improving the Lightning Performance of Electric Power Overhead Distribution Lines," *IEEE2011*.
- [44] F. Heidler, W. Zischank, Z. Flisowski, C. Bouquegneau, and C. Mazzetti, "Parameters of lightning current given in IEC 62305-background, experience and outlook," in *Proceedings of 29th Int. Conference on Lightning Protection*, 2008, p. 6.
- [45] C. Bouquegneau and V. Rakov, *How dangerous is lightning?: Courier Corporation*, 2013.
- [46] V. Rakov, A. Borghetti, C. Bouquegneau, W. Chisholm, V. Cooray, K. Cummins, et al., "CIGRE technical brochure on lightning parameters for engineering applications," in *Lightning Protection (XII SIPDA), 2013 International Symposium on*, 2013, pp. 373-377.
- [47] I. I. Inulec, F. T. Tanasescu, and R. Cramariuc, *The modern problems of electrostatics with applications in environment protection vol. 63: Springer Science & Business Media*, 2012.
- [48] V. Cooray, *The lightning flash: Iet*, 2003.
- [49] J. O. S. Paulino, C. F. Barbosa, I. J. Lopes, and W. D. C. Boaventura, "An approximate formula for the peak value of lightning-induced voltages in overhead lines," *Power Delivery, IEEE Transactions on*, vol. 25, pp. 843-851, 2010.
- [50] P. Chowdhuri, "Parameters of lightning strokes and their effects on power systems," in *Transmission and Distribution Conference and Exposition, 2001 IEEE/PES*, 2001, pp. 1047-1051.
- [51] H. Schmitt and W. Winter, "Simulation of lightning overvoltages in electrical power systems," in *Proc. International Conference on Power System Transients-IPST*, 2001.
- [52] D. Caulker, H. Ahmad, Z. Abdul-Malek, and S. Yusof, "Lightning overvoltages on an overhead transmission line during backflashover and shielding failure," in *Universities Power Engineering Conference (UPEC), 2010 45th International*, 2010, pp. 1-6.
- [53] B. Ravindranath and M. Chander, *Power system protection and switchgear: New Age International*, 1977.
- [54] S. Vujević, D. Lovrić, and Z. Bala, "Numerical approximation of the lightning current function," in *Software, Telecommunications & Computer Networks, 2009. SoftCOM 2009. 17th International Conference on*, 2009, pp. 19-23.

- [55] K. Elrodslly and A. M. Hussein, "CN tower lightning return-stroke current simulation," *Journal of Lightning Research*, vol. 4, pp. 60-70, 2012.
- [56] H.-M. Ren, B.-H. Zhou, V. A. Rakov, L.-H. Shi, C. Gao, and J.-H. Yang, "Analysis of lightning-induced voltages on overhead lines using a 2-D FDTD method and Agrawal coupling model," *Electromagnetic Compatibility, IEEE Transactions on*, vol. 50, pp. 651-659, 2008.
- [57] P. A. L. Part and B. PART, "1: General principles," IEC Standard, pp. 62305-1, 2010.
- [58] N. H. N. Hassan, A. A Bakar, H. Mokhlis, and H. Illias, "Analysis of arrester energy for 132kV overhead transmission line due to back flashover and shielding failure," in *Power and Energy (PECon), 2012 IEEE International Conference on*, 2012, pp. 683-688.
- [59] Z. G. Datsios, P. N. Mikropoulos, and T. E. Tsovilis, "Estimation of the minimum shielding failure flashover current for first and subsequent lightning strokes to overhead transmission lines," *Electric Power Systems Research*, vol. 113, pp. 141-150, 2014.
- [60] J. He, Y. Tu, R. Zeng, J. B. Lee, S. H. Chang, and Z. Guan, "Numerical analysis model for shielding failure of transmission line under lightning stroke," *Power Delivery, IEEE Transactions on*, vol. 20, pp. 815-822, 2005.
- [61] B. Filipović-Grčić, B. Franc, I. Uglešić, V. Milardić, and A. Tokić, "Lightning Overvoltage Performance of 110 kV Air-Insulated Substation," in *International Conference on Power Systems Transients (IPST 2015)*, 2015.
- [62] P. Mikropoulos and T. E. Tsovilis, "Lightning attachment models and maximum shielding failure current of overhead transmission lines: implications in insulation coordination of substations," *Generation, Transmission & Distribution, IET*, vol. 4, pp. 1299-1313, 2010.
- [63] C. Christodoulou, L. Ekonomou, G. Fotis, N. Harkiolakis, and I. Stathopoulos, "Optimization of Hellenic overhead high-voltage transmission lines lightning protection," *Energy*, vol. 34, pp. 502-509, 2009.
- [64] T. Ebdrup, D. Olason, C. L. Bak, and F. F. D. Silva, "Comparison of overhead line lightning performance based on two different tower geometries," in *International Colloquium on Lightning and Power Systems*, 2014.
- [65] L. L. Grigsby, *Power system stability and control vol. 5: CRC press*, 2012.
- [66] C. A. Nucci, "A survey on CIGRE and IEEE procedures for the estimation of the lightning performance of overhead transmission and distribution lines," in *Electromagnetic Compatibility (APEMC), 2010 Asia-Pacific Symposium on*, 2010, pp. 1124-1133.
- [67] I. W. Group, "IEEE guide for improving the lightning performance of transmission lines," ed: New York: IEEE Press, 1997.
- [68] U. Bakshi and M. Bakshi, *Protection And Switchgear: Technical Publications*, 2009.
- [69] J. O. S. Paulino, I. J. da Silva Lopes, W. do Couto Boaventura, and C. Fonseca Barbosa, "An efficient method to assess the indirect lightning performance of overhead lines," in *Lightning Protection (XII SIPDA), 2013 International Symposium on*, 2013, pp. 249-254.
- [70] A. Andreotti, A. Pierno, and V. A. Rakov, "An analytical approach to calculation of lightning induced voltages on overhead lines in case of lossy ground—Part I: Model development," *Power Delivery, IEEE Transactions on*, vol. 28, pp. 1213-1223, 2013.

- [71] T. Thanasaksiri, "Lightning Flashover Rates of Overhead Distribution Lines Applying EMTP and IEEE Std. 1410," *ECTI Transactions on Electrical Engineering, Electronics, and Communications*, vol. 10, pp. 123-129, 2014.
- [72] K. Michishita and Y. Hongo, "Flashover rate of 6.6-kV distribution line due to direct negative lightning return strokes," *Power Delivery, IEEE Transactions on*, vol. 27, pp. 2203-2210, 2012.
- [73] Y. Baba and V. A. Rakov, "Voltages induced on an overhead wire by lightning strikes to a nearby tall grounded object," *Electromagnetic Compatibility, IEEE Transactions on*, vol. 48, pp. 212-224, 2006.
- [74] M. A. Araújo, R. A. Flauzino, R. A. Altafim, O. E. Batista, and L. A. Moraes, "Practical methodology for modeling and simulation of a lightning protection system using metal-oxide surge arresters for distribution lines," *Electric Power Systems Research*, vol. 118, pp. 47-54, 2015.
- [75] C. A. Nucci, A. Borghetti, M. Paolone, P. Boselli, M. Bernardi, S. Malgarotti, et al., "Lightning-Induced Voltages on Overhead Distribution Lines: Theoretical and Experimental Investigation of related Problems and their Impact on Power Quality," *CIGRE*, paper C4-303, Paris, 2004.
- [76] Z. N. Tun and T. Naing, "High Voltage Transmission Line Protection Using Shielding Method," in *Computer and Automation Engineering, 2009. ICCAE'09. International Conference on*, 2009, pp. 363-366.
- [77] A. Piantini and J. M. Janiszewski, "The use of shield wires for reducing induced voltages from lightning electromagnetic fields," *Electric Power Systems Research*, vol. 94, pp. 46-53, 2013.
- [78] S. A. Hosseini, M. Mirzaie, and T. Barforoshi, "Impact of surge arrester number and placement on reliability and lightning overvoltage level in high voltage substations," *International Journal of Electrical Power & Energy Systems*, vol. 65, pp. 146-158, 2015.
- [79] C. Christodoulou, I. Gonos, and I. Stathopoulos, "Lightning performance of high voltage transmission lines protected by surge arresters: a simulation for the Hellenic transmission network," in *Proceedings of the 29th international conference on lightning protection*, Uppsala, Sweden, 2008, pp. 6b-7.
- [80] L. Montañés, M. García-Gracia, M. Sanz, and M. A. García, "An improvement for the selection of surge arresters based on the evaluation of the failure probability," *Power Delivery, IEEE Transactions on*, vol. 17, pp. 123-128, 2002.
- [81] K. Miyake, T. Suzuki, and K. Shinjou, "Characteristics of winter lightning current on Japan Sea coast," *Power Delivery, IEEE Transactions on*, vol. 7, pp. 1450-1457, 1992.
- [82] K. Nakada, T. Yokota, S. Yokoyama, A. Asakawa, M. Nakamura, H. Taniguchi, et al., "Energy absorption of surge arresters on power distribution lines due to direct lightning strokes-effects of an overhead ground wire and installation position of surge arresters," *Power Delivery, IEEE Transactions on*, vol. 12, pp. 1779-1785, 1997.
- [83] S. Yokoyama, "Designing concept on lightning protection of overhead power distribution line," in *Proceedings of the IX International Symposium on Lightning Protection*, Foz do Iguaçu, 2007, pp. 647-662.

- [84] J. A. Martinez-Velasco, *Power system transients: parameter determination*: CRC press, 2009.
- [85] P. Georgilakis and A. Kagiannas, "A novel validated solution for lightning and surge protection of distribution transformers," *International Journal of Electrical Power & Energy Systems*, vol. 63, pp. 373-381, 2014.
- [86] P. Mikropoulos, T. E. Tsovilis, Z. Politis, and A. G. Kagiannas, "Evaluation of fast-front overvoltages arising at a 20/0.4 kV distribution transformer," in *Power Generation, Transmission, Distribution and Energy Conversion (MedPower 2010)*, 7th Mediterranean Conference and Exhibition on, 2010, pp. 1-6.
- [87] P. Mikropoulos, T. E. Tsovilis, and S. G. Koutoula, "Lightning Performance of Distribution Transformer Feeding GSM Base Station," *Power Delivery, IEEE Transactions on*, vol. 29, pp. 2570-2579, 2014.
- [88] T. de Carvalho, A. Piantini, P. Obase, J. Janiszewski, and E. Batista, "Analysis of lightning-caused distribution transformer failures," in *Lightning Protection (XI SIPDA)*, 2011 International Symposium on, 2011, pp. 194-199.
- [89] F. Fernandez and R. Diaz, "Metal oxide surge arrester model for fast transient simulations," in *Int. Conf. Power System Transients (IPAT'01)*, Rio De Janeiro, Brazil, 2001.
- [90] R. C. Dugan, C. W. Williams, and H. Sharma, "Low-side surges in distribution transformers," in *Rural Electric Power Conference, 2007 IEEE*, 2007, pp. C4-C4-7.
- [91] A. N. De Souza, M. G. Zago, O. R. Saavedra, C. C. O. Ramos, and K. Ferraz, "A computational tool to assist the analysis of the transformer behavior related to lightning," *International Journal of Electrical Power & Energy Systems*, vol. 33, pp. 556-561, 2011.
- [92] M. Fernando and V. Cooray, "Lightning surges at distribution transformer secondary," in *Industrial and Information Systems (ICIIS)*, 2010 International Conference on, 2010, pp. 532-537.
- [93] M. Costea and B. Nicoară, "The effects of lightning induced overvoltages on low voltage power networks," in *PowerTech, 2009 IEEE Bucharest*, 2009, pp. 1-6.
- [94] R. C. Dugan, S. S. Kershaw Jr, and S. D. Smith, "Protecting distribution transformers from low-side current surges," *Power Delivery, IEEE Transactions on*, vol. 5, pp. 1892-1901, 1990.
- [95] H. Honda, Y. Hongo, H. Kado, and S. Yokoyama, "Mechanism of Pole-mounted Transformer Damage by Backflow Lightning and Measures against the Damage on Low-voltage Distribution Line," *IEEJ Transactions on Power and Energy*, vol. 128, pp. 836-844, 2008.
- [96] A. De Conti, F. H. Silveira, and S. Visacro, "On the role of transformer grounding and low-voltage surge arresters on protecting loads in complex distribution networks," in *Lightning Protection (ICLP)*, 2012 International Conference on, 2012, pp. 1-7.
- [97] M. Marz and S. R. Mendis, "Protecting load devices from the effects of low-side surges," *Industry Applications, IEEE Transactions on*, vol. 29, pp. 1196-1203, 1993.
- [98] T. Sorensen, F. Jensen, N. Raben, J. Lykkegaard, and J. Saxov, "Lightning protection for offshore wind turbines," in *Electricity Distribution, 2001. Part 1: Contributions. CIRED*.

16th International Conference and Exhibition on (IEE Conf. Publ No. 482), 2001, p. 5 pp.
vol. 4.

- [99] D. R. Poelman, W. Schulz, G. Diendorfer, and M. Bernardi, "The European lightning location system EUCLID–Part 2: Observations," *Natural Hazards and Earth System Sciences*, vol. 16, pp. 607-616, 2016.
- [100] D. C. Chisholm Institute of TAFE, "Design overhead distribution systems ", ed, 2014.

Appendix

Direct lightning strike to the tower for unshielded power line

```

close all
clear all
%Basic data
h_t=13.05; %tower height(m)
h_ca=9.72; %cross arm(m)
R_1=10; %footing resistance(ohm)
R_2=40; %footing resistance(ohm)
Z_t=100; %tower surge impedance(ohm)
Z_ch=450;%lightning surge impedance(Ohm)
I_p=267*10^3;%lightning peak current(A)
c=3*10.^8;%velocity of light in free space(m/s)
t_h=50;%time to half value)
t_f=0.5;%ftont time(micro-second)
v=10.^8;%lightning stroke velocity(m/micro-second)
% v=c/(sqrt(1+(500/I_p)))*10.^6
%voltage reflection coefficients at the lower end of the tower with
%defferent footing resistance
a_r1=(R_1-Z_t)/(R_1+Z_t)
a_rb1=(R_2-Z_t)/(R_2+Z_t);
%voltage reflection coefficients at the upper end of the tower
a_r2=(Z_ch-Z_t)/(Z_ch+Z_t)
T_t=h_t/v%the time of travel from the tower top to its foot(μs)
T_ca=h_ca/v%time of travel from the cross arm to the tower foot(μs)
%current reflection coefficients

for t=1:50
    n=t+1;
    alpha_1=(I_p/t_f);
    alpha_2=((2^t_h-t_f)*I_p)/(2*t_f*(t_h-t_f))

%initial tower current in a function of time
I_t=(alpha_1*t.*heaviside(t))-(alpha_2*(t-t_f).*heaviside(t-t_f));
%initial tower voltage in function of time
V_to=Z_t*I_t;
% V_t1= V_to by replacint t=(t-(2^n-1)*T_t+T_ca)
I_1=(alpha_1*(t-(2^n-1)*T_t+T_ca).*heaviside((t-(2^n-1)*T_t+T_ca)))-
(alpha_2*((t-(2^n-1)*T_t+T_ca)-t_f).*heaviside((t-(2^n-1)*T_t+T_ca)-t_f));
V_t1=Z_t*I_1;
% V_t1= V_to by replacint t=(t-(2^n-1)*T_t-T_ca)
I_2=(alpha_1*(t-(2^n-1)*T_t-T_ca).*heaviside((t-(2^n-1)*T_t-T_ca)))-
(alpha_2*((t-(2^n-1)*T_t-T_ca)-t_f).*heaviside((t-(2^n-1)*T_t-T_ca)-t_f));
V_t2=Z_t*I_2;
%steps for calculating direct unshield insulator or cross arm voltage
%@R=10 ohm;
V_cal=sum(a_r1*a_r2).^ (n-1).*V_t1.*heaviside(t-(2^n-1)*T_t+T_ca);
V_ca2=a_r1*sum(a_r1*a_r2).^ (n-1).*V_t2.*heaviside(t-(2^n-1)*T_t-T_ca);
V_ca(t)=(V_cal+V_ca2)/10.^6+2.6;
%@R=20 ohm
V_cb1=sum(a_rb1*a_r2).^ (n-1).*V_t1.*heaviside(t-(2^n-1)*T_t+T_ca);
V_cb2=a_rb1*sum(a_rb1*a_r2).^ (n-1).*V_t2.*heaviside(t-(2^n-1)*T_t-T_ca);
V_cb(t)=(V_cb1+V_cb2)/10.^6+4.2;

```

```

counter(t)=t;
t_f=t_f+0.5;
end
%voltage simulation in function of time
plot(counter-1,V_ca)
xlabel('Time  $\mu$ s')
ylabel('Voltage MV')
title('')
hold on
plot(counter-1,V_cb)
legend('R1=10 Ohm','R2=40 Ohm')

```

Direct lightning strike to the phase conductor for unshielded power line

```

close all
clear all
%Basic data
T_1=19;
T_2=485;
m=10;
Z_p=450;
I_p=267*10.^3;
Q=exp((-T_1/T_2)*(m*T_2/T_1).^(1/m));
for t=1:500
    I=((I_p/Q)*((t/T_1).^m)/(1+(t/T_1).^m))*exp(-t/T_2)
    V(t)=(Z_p*I/2)/10.^6
    counter(t)=t;
end
%voltage simulation in function of time
plot(counter-1,V)
xlabel('Time  $\mu$ s')
ylabel('Voltage MV')

```

Direct lightning strike to the shielded power line

```

close all
clear all
%Basic data
h_t=13.05;%tower height(m)
h_ca=9.72;%cross arm height(m)
h_p=10;%phase conductor height(m)
R_1=10;%footing resistance(ohm)
R_2=40;%footing resistance(ohm)
Z_t=100;%tower surge impedance(ohm)
h_s=13.05 ;%shield wire height
r_s= 0.05 ;%radius of the shield wire

Z_s=60*log(2*h_s/r_s);%shield wire surge impedance(ohm)
d_p1=3.66;%the distance from the shield wire to the image of the phase
conductor in the ground
d_ps=3.66;%distance from the shield wire to the phase conductor
Z_12=60*log(d_p1/d_ps); %surge impedance between phase conductor and shield
wire
K_sp=Z_12/Z_s;%electromagnetic coupling with shield wire
%Z_strike=(0.5*Z_s*Z_t)/(0.5*Z_s+Z_t);%impedance from the striking point
Z_eq=(0.5*Z_s*Z_t)/(0.5*Z_s+Z_t);
Z_ch=450;%lightning surge impedance(Ohm)

```

```

I_p=17*10.^3;%lightning peak current(A)
c=3*10.^8;%velocity of light in free space(m/s)
t_h=50;%time to half value(micro-second)
t_f=0.5;%front time(micro-second)
%t=(0:20);%simulation time(micro-second)
%n=1:21%number of reflected wave point
v=10.^8;%lightning stroke velocity(m/micro-second)
%v=c/(sqrt(1+(500/I_p)))*10.^6
%voltage reflection coefficients at the lower end of the tower with
%defferent footing resistance
a_r1=(R_1-Z_t)/(R_1+Z_t);
a_rb1=(R_2-Z_t)/(R_2+Z_t);

a_r3=(((0.5*Z_s*Z_ch)/(0.5*Z_s+Z_ch))-
Z_t)/(((0.5*Z_s*Z_ch)/(0.5*Z_s+Z_ch))+Z_t);

%a_r3=(((0.5*Z_s*Z_ch+Z_ch/0.5*Z_ch+Z_ch)-
Z_t)/(((0.5*Z_s*Z_ch+Z_ch/0.5*Z_ch+Z_ch)+Z_t));
a_t2=1+a_r3;%voltage of transmission line coefficient
T_t=h_t/v%the time of travel from the tower top to its foot(μs)
T_ca=h_ca/v%time of travel from the cross arm to the tower foot(μs)
%current reflection coefficients

for t=1:50
    n=t+1;
alpha_1=(I_p/t_f);
alpha_2=((2*t_h-t_f)*I_p)/(2*t_f*(t_h-t_f))

%initial tower current in a function of time

I_t=(alpha_1*t.*heaviside(t)-(alpha_2*(t-t_f).*heaviside(t-t_f)));
%initial tower voltage in function of time
V_to=Z_eq*I_t;
% V_t1= V_to by replacing t=(t-(2*n-1)*T_t+T_ca)
I_1=(alpha_1*(t-(2*n-1)*T_t+T_ca).*heaviside((t-(2*n-1)*T_t+T_ca)))-
(alpha_2*((t-(2*n-1)*T_t+T_ca)-t_f).*heaviside((t-(2*n-1)*T_t+T_ca)-t_f));
V_t1=Z_eq*I_1;
% V_t1= V_to by replacing t=(t-(2*n-1)*T_t-T_ca)
I_2=(alpha_1*(t-(2*n-1)*T_t-T_ca).*heaviside((t-(2*n-1)*T_t-T_ca)))-
(alpha_2*((t-(2*n-1)*T_t-T_ca)-t_f).*heaviside((t-(2*n-1)*T_t-T_ca)-t_f));
V_t2=Z_eq*I_2;
%shielded power line
I_3=(alpha_1*(t-2*n*T_t).*heaviside(t-2*n*T_t)-(alpha_2*(t-2*n*T_t-
t_f).*heaviside(t-2*n*T_t-t_f)));

%@R=10 ohm
V_tt1=(Z_eq*I_t).*heaviside(t)+a_t2*a_r1*sum(a_r1*a_r3).^(n-
1)*(Z_eq*I_3).*heaviside(t-2*n*T_t);
%@R=40 ohm
V_tt2=(Z_eq*I_t).*heaviside(t)+a_t2*a_rb1*sum(a_rb1*a_r3).^(n-
1)*(Z_eq*I_3).*heaviside(t-2*n*T_t);

%R=10 ohm
V_ca3=sum(a_r1*a_r3).^(n-1).*(Z_eq*I_1).*heaviside(t-(2*n-1)*T_t+T_ca);
V_ca4=a_r1*sum(a_r1*a_r3).^(n-1).*(Z_eq*I_2).*heaviside(t-(2*n-1)*T_t-T_ca);
V_insl(t)=((V_ca3+V_ca4)-(K_sp*V_tt1))/10.^3+23;
%@R=40 ohm

```

```

V_ca5=sum(a_rb1*a_r3).^(n-1).*(Z_eq*I_1).*heaviside(t-(2*n-1)*T_t+T_ca);
V_ca6=a_rb1*sum(a_rb1*a_r3).^(n-1).*(Z_eq*I_2).*heaviside(t-(2*n-1)*T_t-T_ca);
V_ins2(t)=(V_ca5+V_ca6)-(K_sp*V_tt2))/10.^3+37.7;

counter(t)=t;
t_f=t_f+0.5;
    end
% %unshielded voltage simulation in function of time

plot(counter-1,V_ins1)
hold on
xlabel('Time μs')
ylabel('Voltage kV')
title('Direct shielded line')
plot(counter-1,V_ins2)
legend('R1=10 Ohm', 'R2=40 Ohm')

```