



UNIVERSITY of  
RWANDA

COLLEGE OF SCIENCE  
AND TECHNOLOGY

Regional Centre of Excellence in Biomedical Engineering and e-Health (CEBE)

**DESIGN AND PROTOTYPING OF BODY MASS INDEX-BASED MONITORING  
DEVICE FOR OBESITY EARLY DIAGNOSIS**

By:

HATEGEKIYAREMYE Evariste

Reference Number: 222000796

A Dissertation Submitted to the Regional Centre of Excellence in Biomedical Engineering and e-Health (CEBE), University of Rwanda as partial fulfillment of the requirements for the Master's Degree in Biomedical Engineering.

**Supervised by:**

**Dr. Philbert NSENGIYUMVA**

**and**

**Dr. TWAHIRWA Evariste**

## DECLARATION

I, HATEGEKIYAREMYE Evariste, declare that this dissertation entitled “**Design and prototyping of Body Mass Index- based monitoring device for obesity early diagnosis**” is my original work based on research and prototype and has not been submitted for any other degree or professional qualification.

Student Name:

HATEGEKIYAREMYE Evariste

Student Reference Number: 222000796

Student Signature:

Date: 08/10/2024



UNIVERSITY of  
RWANDA

COLLEGE OF SCIENCE  
AND TECHNOLOGY

Regional Centre of Excellence in Biomedical Engineering and e-Health (CEBE)

**CERTIFICATE**

This is to certify that the project entitled “**Design and prototyping of Body Mass Index based monitoring device for obesity early diagnosis**” is a record of original work done by HATEGEKIYAREMYE Evariste (Reference number:222000796), a MSc. Degree student in Biomedical Engineering.

This work has been submitted under the guidance of Dr. Philibert NSENGIYUMVA and Dr. TWAHIRWA Evariste.

Main Supervisor:

14/05/2024

Dr. Philibert NSENGIYUMVA

Co-Supervisor:

14/05/2024

Dr. TWAHIRWA Evariste

Biomedical Engineering Master's Program Coordinator

Dr. Gerard RUSHINGABIGWI

## **ACKNOWLEDGMENT**

I would like to recognize my supervisors Dr. Philbert NSENGIYUMVA and Dr. TWAHIRWA Evariste for their invaluable guidance, coaching and mentoring leading to the writing of this thesis. My sincere thanks also go to my family members especially my spouse NIYONAMBAJE Marie Louise for her endless love, emotional support and encouragement during my masters' studies and thesis' writing.

I cannot forget the funds offered by University of Rwanda through Center of Excellence in Biomedical engineering and E-health (CEBE) which make my masters' studies and dissertation work possible.

I am grateful to CEBE management for your guidance and support.

## ABSTRACT

Obesity is one of the most significant risk factors of the occurrence of non-communicable diseases and associated increased healthcare costs in the twenty-first century [1].

Obesity is a global health concern associated with numerous comorbidities and increased mortality rates. In 2019, there were an estimated 5 million obesity-related deaths from NCDs (non-communicable diseases), which corresponds to 12% of all NCDs deaths [2]. Early diagnosis and intervention are critical in combating obesity. The public do need to know how to check their obesity in a self-monitoring way to manage the associated risks. The existing methods of obesity diagnosis require consulting health care providers which is found costly and time consuming. This project focuses on the design and prototyping of a novel monitoring device tailored for early detection of obesity using Body Mass Index (BMI) as a key metric. The suggested device may replace the existing conventional computing method calculating single parameter either height or weight and apply formula to find BMI. This project consists of introduction where preliminary BMI information is spotlighted, literature review encompassing different consulted and cited related research works; the project methods and materials comprising all required materials design specifications, prototype development and testing on individual samples and finally the project conclusion and recommendations. This project uses specific sensors like ultrasonic sensor and load cell to detect respectively personal body height and mass. Node MCU for storing and processing input data; and LCD (Liquid Crystal Display) to display the detected body parameters for obesity early diagnosis. The project entails mainly prototype design, development and testing. The proposed device aims to empower individuals with monitoring their BMI levels conveniently at home, enabling early detection of obesity status and facilitating proactive lifestyle modifications or medical interventions. Through design refinement and prototype testing, this project produces a user-friendly device capable of contributing to the early diagnosis and management of obesity, thereby promoting healthier lifestyles and reducing the burden of obesity-related diseases on individuals and healthcare systems globally.

**Key words:** Obesity, diagnosis, Body mass index, weight, height, Node MCU, load cell, ultrasonic sensor.

## TABLE OF CONTENTS

DECLARATION.....	i
CERTIFICATION.....	ii
ACKNOWLEDGMENT.....	iii
ABSTRACT.....	iv
TABLE OF CONTENTS.....	v
LIST OF FIGURES.....	viii
LIST OF TABLES.....	ix
LIST OF ACRONYMS.....	x
1 INTRODUCTION.....	1
1.1 Overview and definitions.....	1
1.2 Background.....	2
1.3 Problem statement.....	3
1.4 Project objectives.....	3
1.4.1 Main objective.....	3
1.4.2 Specific Objectives.....	4
1.5 Significance of the project.....	4
2 Literature Review.....	5
2.1 Project related literatures.....	5
2.2 What is BMI?.....	6
2.3 Why use BMI for health status control?.....	6
2.4 Why measure BMI?.....	6
2.5 A sensor.....	6
2.6 Ultrasonic Sensor.....	7
2.6.1 Definition.....	7
2.6.2 Ultrasonic sensor working principle.....	7
2.6.3 Ultrasonic sensor pins description.....	7
2.7 A mass sensor:.....	8

2.8	Load cells.....	8
2.8.1	Kinds of load cells .....	8
2.9	A microcontroller:.....	9
2.10	Arduino .....	9
2.10.1	Definition.....	9
2.10.2	Elements of Arduino board .....	9
2.11	Node MCU.....	12
2.11.1	Definition:.....	12
2.11.2	Advantages of Node MCU .....	13
2.11.3	Comparison between Arduino and Node MCU .....	13
2.12	A display device.....	13
2.12.1	Definition.....	13
2.12.2	Liquid crystal display device.....	13
2.12.3	6X2 alphanumeric LCD. ....	14
2.12.4	I2C interface 20x4 LCD display module.....	14
2.13	Breadboard.....	14
2.13.1	Definition.....	14
2.14	Printed Circuit Board.....	14
2.15	A switch .....	15
2.15.1	Definition.....	15
2.15.2	A push button switch .....	15
3	Methods and Materials .....	16
3.1	Methods .....	16
3.1.1	Data collection methods .....	16
3.1.2	Sampling methods .....	16
3.1.3	Population.....	16

3.2	Materials design.....	16
3.2.1	BMI based monitoring system requirements.....	16
3.2.2	Microcontroller requirements.....	18
3.2.3	Choosing project components .....	18
3.3	Materials implementation .....	28
3.3.1	Hardware mounting and connection.....	28
3.3.2	Software Development .....	32
3.3.3	Prototype working verification.....	32
4	Conclusion and Recommendations: .....	40
4.1	Conclusion .....	40
4.2	Recommendations.....	40
5	References .....	42
6	Appendix: Firmware code alongside with comments.....	45

## LIST OF FIGURES

FIGURE 3-1 SYSTEM PHYSICAL DIMENSIONS .....	18
FIGURE 3-2 PROJECT BLOCK DIAGRAM .....	21
FIGURE 3-3 PROJECT CIRCUIT DIAGRAM .....	22
FIGURE 3-4 SYSTEM FLOW CHART.....	25
FIGURE 3-5 SYSTEM LOGIN PAGE .....	26
FIGURE 3-6 SYSTEM INTERFACE SHOWING USER DATA IN THE CLOUD .....	27
FIGURE 3-7 MOUNTED NODE MCU AND HX711 MODULE .....	28
FIGURE 3-8 MOUNTED MICROCONTROLLER, HX711 MODULE WITH A SWITCH TO CONTROL THE SYSTEM POWER. .....	29
FIGURE 3-9 MOUNTED I2C LCD .....	29
FIGURE 3-10 WEIGHT SENSOR SUPPORTED UNDER WOODEN STRUCTURE .....	30
FIGURE 3-11 MOUNTED ULTRASONIC SENSOR ON WOODEN STRUCTURE .....	30
FIGURE 3-12 WEIGHT WOODEN SUPPORTING STRUCTURE.....	31
FIGURE 3-13 THE WHOLE DEVELOPED PROTOTYPE IN UNFOLDED (A) AND FOLDED FORMS (B) &(C) RESPECTIVELY .....	31
FIGURE 3-14 PROTOTYPE WORKING VERIFICATION.....	33
FIGURE 3-15 MEASURED WEIGHT USING WEIGHING SCALE AGAINST MEASURED WEIGHT USING BMI MONITORING SYSTEM PROTOTYPE .....	36
FIGURE 3-16 MEASURED HEIGHT USING WEIGHING SCALE AGAINST MEASURED HEIGHT USING BMI MONITORING SYSTEM PROTOTYPE .....	36
FIGURE 3-17 DIFFERENCE IN WEIGHT VERSUS DIFFERENCE IN HEIGHT.....	37
FIGURE 3-18 MEASURED PARAMETERS PRESENTATION IN INITIAL STATE .....	37
FIGURE 3-19 MEASURED PARAMETERS PRESENTATION WITH OBESITY STATUS OF NORMAL .....	38
FIGURE 3-20 MEASURED PARAMETERS PRESENTATION WITH OBESITY STATUS OF OVERWEIGHT .....	38
FIGURE 3-21 MEASURED PARAMETERS PRESENTATION WITH OBESITY STATUS OF UNDERWEIGHT .....	39

**LIST OF TABLES**

**TABLE 1: RESULTS OBSERVED FOR WEIGHING SCALE AND TAPE MEASURE MEASUREMENTS AND THOSE FOUND FROM BMI MONITORING SYSTEM.....33**

## LIST OF ACRONYMS

AVR	Automatic voltage Regulator
BMI	Body Mass Index
CDC	Centre for Disease Control
CEBE	Center of Excellence in Biomedical engineering and E-health
CLI	Command line interface
GNB	Gaussian Naïve Bayes
I2C	Inter-Integrated Circuit
ICSP	In-Circuit Serial Programming
IDE	Integrated Development Environment
IOT	Internet of Things
JST	Japan Solderless Terminal
KHz	Kilohertz
LCD	Liquid crystal display device Liquid-crystal display
LED	Light Emitting Diode
LiPo	Lithium Polymer
MHz	Megahertz
NCD	Non -Communicable Disease
OS	Operating System
PCB	Printed circuit board
PWM	Pulse Width Modulation
SPI	Serial Peripheral Interface
SVM	Support-Vector Machines
UART	Universal Asynchronous Receiver-transmitters
USB	Universal Serial Bus
WHO	World health Organization

# 1 INTRODUCTION

## 1.1 Overview and definitions

Obesity refers to abnormal accumulation of body fats which may impair human health. BMI is the simple determinant of overweight and obesity. It is useful to classify overweight and obese status in individuals.

The prevalence of obesity is drastically rising globally, and it is now considered as a critical public health issue. According to the World Health Organization WHO (2016), there are just fewer than 2 billion overweight adults in the world. More than 600 million of them are considered obese. Around 40% of adults were overweight in 2016 and just fewer than 15% were obese. The global prevalence of obesity has increased threefold between 1975 and 2016. If the trend continues to rise, it is estimated that close to one third of the world adult population will be overweight and more than 1 billion will be obese by 2025 [3].

Data from the Rwanda 2012–2013 NCD STEP survey showed that while 2.8% participants were obese, 14.3% were overweight and 7.8% underweight. Of these participants, women were mostly obese (4.7%) and overweight (19%) compared to men (0.8 and 9.1%, respectively). In 2016, the prevalence of overweight [body mass index (BMI)  $25 \text{ kg/m}^2$  ] and obesity (BMI  $\geq 30 \text{ kg/m}^2$  ) in adults 25 years and older was 25.1 and 5.8%, respectively, according to WHO GHO age-standardized estimates [4].

According to [4], the prevalence of obesity in Rwanda was more predominant in urban areas (10.2%) and in Kigali city (7.7%), with 14.3% of the adult population, 15–64 years old, being overweight as observed in 2016. BMI is the metric currently in use for defining anthropometric height/weight characteristics in adults and for classifying (categorizing) them into groups. The common interpretation is that it represents an index of an individual's fatness [5].

Anthropometry is one of the most widely applied methods to assess the size, proportions and composition of the human body and it is universally applicable, inexpensive, non-invasive, and can be used to predict health, performance and survival of individuals and populations [5].

It's important to be at a healthy weight. Body Mass Index or BMI and waist size are two numbers that can help you decide if your weight is healthy, or if you need to make some changes [6].

Uncontrolled weight gain leads to overweight and obesity which has become a significant driver of the global rise in chronic, non-communicable diseases and is itself now considered a chronic disease.

BMI is a simple, inexpensive, and noninvasive surrogate measure of body fat [7] body mass index (BMI) is a widely used tool to evaluate overweight and obesity based on two anthropometric parameters, height and weight [8]. BMI values serve to classify people among different health conditions through a set of cut-off points of scales.

The BMI scales are classified as below [9]:

- a) BMI less than 18.5 determines underweight condition;
- b) BMI from 18.5 to less than 25.0 determines normal weight condition;
- c) BMI from 25.0 to 29.9 determines overweight condition;
- d) BMI from 30 and above determines obesity conditions.

## **1.2 Background**

The body mass index (BMI) was described back in 1832 by Adolphe Quetelet [10] and then was validated by Ancel Keys in 1972[11]. BMI is the ratio of body weight expressed in kilograms, divided by height squared with the height expressed in meters.

Modern generations of humans pay a lot of attention to a healthy lifestyle, and the body mass index is one of the most popular determinants of health. BMI indicator applies in different fields of science, trying to determine different aspects of its impact on physical, psychological and social aspects of life [9].

Body mass index helps to estimate the risk of being underweight and obese of examined person. The phenomenon of obesity and underweight may be associated with the development of diseases classified as civilization diseases, such as diabetes, stroke, atherosclerosis, hypertension and nutrition disorders [9].

With the stated background, the determination of personal BMI is found paramount in daily life to deal with obesity difficulties.

### **1.3 Problem statement**

Obesity has become a pervasive global health issue, with significant implications for individual well-being and healthcare systems worldwide. Obesity is a chronic metabolic disease characterized by an increase in body fat stores. It is a gateway to ill health and has become one of the leading causes of disability and death, affecting not only adults but also children and adolescents worldwide [10]. The lack of effective and accessible methods for early self-diagnosis and monitoring of obesity exacerbates its associated health risks and complications. Current diagnostic approaches often rely on periodic clinical assessments, which are time-consuming, costly, and may not capture subtle changes in body composition over time. Additionally, these methods often require specialized equipment and expertise, limiting their widespread availability and adoption. To address these challenges, there is a pressing need for innovative solutions that empower individuals to monitor their body mass index (BMI) conveniently and accurately at home. The proposed solution is to raise public awareness by enabling early detection of obesity status, facilitating timely interventions and lifestyle modifications to mitigate associated health risk. Knowing your body mass index (BMI) is significant to assist in preventing non-communicable diseases such as type 2 diabetes, high blood pressure, heart or blood vessel problems, cardiovascular disease, and musculoskeletal problems. It is the easiest and least expensive way to measure it [12]. The proposed method is fast with no need for user training and technician intervention. Design and prototyping of body mass index-based monitoring device for obesity early diagnosis provides the solution through a developed device sensing height and mass measurements for a human body which are stored and processed by the Node MCU microcontroller to display the corresponding BMI as well as obesity status diagnosis.

### **1.4 Project objectives**

#### **1.4.1 Main objective**

This project aims at designing and prototyping Body mass index-based monitoring device for obesity early diagnosis.

### **1.4.2 Specific Objectives**

- ✓ Design a Body mass index monitoring device
- ✓ Prototyping a Body mass index monitoring device
- ✓ Testing the prototype of BMI monitoring device to diagnose obesity

### **1.5 Significance of the project**

The design and prototyping of body mass index-based monitoring device for obesity early diagnosis is significant to assist people with assessing their obesity status, provision of notification message on LCD display to adopt required health styles. The project is expected to impact lives with obesity self-monitoring and improving public health conditions to prevent obesity which is intertwined with non-communicable diseases. It will enable the public to access personal BMI self-testing device with usability.

## **2 Literature Review**

### **2.1 Project related literatures**

Karim, A. D. A, et al. in [13] suggested the solution of an IOT based Portable Real-Time BMI nutritional advice enabling to calculate user's BMI and keep current and previous user's record to help people to monitor their BMI as a way of keeping a healthy weight. The proposed solution is based on providing nutritional advice to people according to their detected BMI to impact people with awareness to prepare a balanced diet. Design and prototyping of body mass index-based monitoring device for obesity early diagnosis serves to notify obesity status and recommends the consultation of health care providers for further advice.

Nanak Zakaria et al. [14] proposed solutions to support the healthier body through measuring devices and android applications, for height measurement using ultrasonic sensors, weight using load cell sensors and Node MCU ESP8266 as data processor. The results of measuring height and weight were expected to appear on an LCD, the results of Body Mass Index (BMI) and the recommended solutions to meet standard body numbers in calculating BMI appear on the android application. This article suggested the method of accessing BMI measurements through android applications which has limitation when people have no smart phone or not able to use the smart phone as well the method is costly.

Roopa Govindarajan et al. [15] proposed a solution of self-monitoring system to control obesity. The proposed system offers a personalized profile creation feature for every user which allows the user to store his physical record details. Based on the entered data, the system calculates the BMI and performs various predictive analysis resulting in calculation of parameters which may directly or indirectly affect the individual's obesity level. The suggested method requires the creation of a user profile and entering personal records, which is time-consuming and needs some skills.

Amani et al. [16] proposed a solution of using machine learning classification algorithms for classifying body mass index of people for clinical decisions and they used Random Forest (RF), Gaussian Naïve Bayes (GNB), Decision Tree (DT), Support-Vector Machines (SVM), Multi-layer Perceptron (MLP), K-nearest neighbors (KNN) and Logistic Regression (LR) to classify people based on BMI data. The performance of used algorithms was evaluated with Precision, Recall, Mean Squared Errors (MSE) and Accuracy. All programming done in Python.3.7 in Jupyter Notebook. For the method suggested above, all stated algorithms used the predictive model from the existing data set to categorize personal BMI despite design and prototyping of body

mass index-based monitoring device for obesity early diagnosis provides BMI current measurement without relying on existing collection of data.

## **2.2 What is BMI?**

Body mass index (BMI) is a measure of weight adjusted for height, calculated as weight in kilograms divided by the square of height in meters ( $\text{kg}/\text{m}^2$ ). Although BMI is often considered an indicator of body fatness, it is a surrogate measure of body fat because it measures excess weight rather than excess fat [12] body mass index (BMI) is the metric currently in use for defining anthropometric height/weight characteristics in adults and for classifying (categorizing) them into groups [7].

## **2.3 Why use BMI for health status control?**

BMI measurements rely solely on height and weight and with access to the proper equipment, individuals can have their BMI routinely measured and calculated with reasonable accuracy [12]. BMI status depends on individual weight; the increase of body weight affects personal health conditions with that extent BMI may be used to monitor health status.

## **2.4 Why measure BMI?**

The body mass index (BMI) is a measurement derived from a person's height and weight. BMI provides a reliable indicator of body fatness for most people and may be used to screen body weight categories that may lead to different health problems [17].

## **2.5 A sensor**

A sensor is any device that receives a signal or stimulus to respond to the stimulus in the form of an electrical signal. Its output signals correspond to some forms of electrical signal, such as current or voltage [18].

Three basic components of a sensor are: a sensor element, sensor packaging and connections, and sensor signal processing hardware.

## 2.6 Ultrasonic Sensor

### 2.6.1 Definition

Ultrasonic sensor is a sensor which is used to measure the distance by using the ultrasonic waves. This sensor uses the transducer for both sending and receiving ultrasonic pulses which relay back information about the object's proximity [[Error! Hyperlink reference not valid.](#)].

### 2.6.2 Ultrasonic sensor working principle

Ultrasonic sensor is a sensor that works based on the principle of sound wave reflection and is used to detect the presence of a certain object in front of it. Its working frequency is in the area above the sound wave from 40 KHz to 400 KHz. The ultrasonic sensor consists of two units, namely a transmitting unit and a receiving unit. This sensor is suitable for electronic applications that require distance detection, including for sensors on robots. It uses 4 pins [14]. Ultrasonic sensor works by transmitting a pulse of sound, much like sonar detectors, outside the range of human hearing. This pulse travels away from the range finder in a conical shape at the speed of sound (340 m/s). The sound reflects off an object and back to the range finder. The sensor interprets this as an echo and calculates the time interval between sending the signal and receiving the echo. This interval is then computed by a controller to determine the distance of the object [20].

Based on ultrasonic sensor working principle, it is found suitable for measuring personal height.

Distance from the sensor to the obstacle calculation:

**Distance= T round trip\*V sound/2** Where T stands for transmission or reflection time of sensor wave.

### 2.6.3 Ultrasonic sensor pins description

Ultrasonic sensor consists of 4 pins namely Vcc, Trig, Echo and GND :

- **VCC pin:** It is used to supply power to the sensor
- **Trig (Trigger):** Trigger pin is an input pin. This pin has to be kept high for 10us to initialize measurement by sending ultrasound wave.

- **Echo (Receive pin):** Echo pin is an Output pin. This pin goes high for a period of time which will be equal to the time taken for the US wave to return back to the sensor. It receives the US wave reflected from the obstacle.
- **GND (Ground pin):** This pin is connected to the Ground of the system.

## **2.7 A mass sensor:**

A mass sensor is any device that measures the mass of an object or substance. It can be used in different applications like weighing scales, chemical analysis, and medical diagnostics.

## **2.8 Load cells**

A load cell is referred to as any transducer or sensor used to convert the load applied on it into an electronic signal. The electronic signal may be a voltage change, current change or frequency change depending on the kind of load cell and circuitry used.

### **2.8.1 Kinds of load cells**

The load cells are mainly classified in strain gauge load cells, hydraulic load cells, pneumatic load cells, capacitive load cells and piezoelectric transducers

#### **Strain gauge load cells**

Strain Gauge load cells convert pressure differentials to measurements and operate through changes in electrical resistance. The strain gauge load cell is mostly used, and it is a mechanical element of which the force is being sensed by the deformation of a strain gauge on the elements. Each strain gauge responds to the local strain at its location, and the force measurement depends on the combination of these individual strain measurements [21].

#### **Hydraulic load cells**

Hydraulic load cells convert a load to hydraulic pressure. The measured load is applied to a load platform attached to a piston. The piston generates hydraulic pressure to a confined fluid.

#### **Pneumatic load cells**

Pneumatic load cells work similarly to their hydraulic ones in that they convert fluid pressure into a load measurement. However, the pressurized fluid in a pneumatic load cell is a type of gas, oftentimes air.

## **Capacitive load cells**

Capacitive load cells' function is based on the ability of a material or system to store a charge. They consist of two parallel plates with a gap between them.

## **Piezoelectric transducers**

Piezoelectric transducers operate with basis on the piezoelectric effect. The piezoelectric effect is a natural property of materials such as quartz crystal and other ceramics to produce an electric charge when the mechanical stress is applied on them.

## **2.9 A microcontroller:**

### **Definition**

A microcontroller is defined as a small computer on chip in the form of a compact integrated circuit designed to control a specific operation in an embedded system.

Generally, a microcontroller comprises a processor, memory and input/output (I/O) peripherals on a single chip. A microcontroller is a small, low-cost and self-contained computer-on-a-chip that can be used as an embedded system.

Microcontrollers exist in various types; however, this research work focuses on Arduino and Node MCU.

## **2.10 Arduino**

### **2.10.1 Definition**

Arduino is an open-source microcontroller which can be easily programmed, erased and reprogrammed at any instant of time. Introduced in 2005 the Arduino platform was designed to provide an inexpensive and easy way for hobbyists, students and professionals to create devices that interact with their environment using sensors and actuators [22].

### **2.10.2 Elements of Arduino board**

Arduino board consists of hardware and software components.

#### **Hardware**

The Arduino hardware as known as Arduino Development Board, and it has many components that enable its function. Here are some of its main component blocks that support its functioning:

- **Microcontroller:** This is considered as the heart of the development board, that works as a minicomputer able to send and receive information or command to the auxiliary devices connected to it. The microcontroller has different specifications from one board to another.
- **External Power Supply:** This is used to supply the Arduino development board with a regulated voltage varying from 9 to 12 volts.
- **USB plug:** This plug is a very important port on this board. It is used to upload a program to the microcontroller using a USB cable. It also has a regulated power of 5V which also powers the Arduino board when there is no external power supply.
- **Internal Programmer:** The developed software code can be uploaded to the microcontroller via USB port, without an external programmer.
- **Reset button:** This button is present on the board and can be used to reset the Arduino microcontroller.
- **Analog Pins:** There are some analog input pins ranging from A0 – A7 (typical). These pins are used for the analog input / output. The number of analog pins also varies from board to board.
- **Digital I/O Pins:** The microcontroller comprises digital input pins ranging from 2 to 16 (typical). These pins are used for the digital input / output. The number of digital pins changes depending on the board.
- **Power and GND Pins:** There are pins on the development board that provide 3.3, 5 volts and ground through them.

### Arduino software

The Arduino software is for developing code and it is known as the Arduino IDE (Integrated Development Environment). Built-up with the 8-bit Atmel AVR microcontrollers that are manufactured by Atmel or a 32-bit Atmel ARM, these microcontrollers can be programmed easily using the C or C++ language in the Arduino IDE. The Arduino IDE provides a simplified integrated platform that can run on almost all personal computers [23]. IDE contains different parts as explained below:

- **Console Toolbar:** This toolbar comprises different buttons like compile, upload, new, open, save, and serial monitor.

- **Text editor:** This is the space where programming code can be written using C/C++ programming language.
- **Message area:** It is used to display an error and gives feedback on saving and exporting the code.
- **Text:** The console displays text output by the Arduino environment including complete error messages and other information [24].

### Reasons to use Arduino

Arduino Co-founder Massimo Banzi mentioned some very important reasons to use Arduino boards namely:

- **Active User Community:** Arduino users can post a message and share their experiences. If a problem occurs using the Arduino board, the user can get support from others through sharing his/her problem to a community platform then other users can normally help by giving solutions or guidance for addressing the problem. It is made up of everyone from hobbyists, students, designers and engineers across the world.
- **Growth of Arduino:** Arduino microcontrollers are not expensive compared to their competitors. This makes it preferable for beginners to get started quickly.
  - **Simplicity:** For beginners, it is very simple to use Arduino.
  - **Inexpensive hardware:** Arduino platform is free to use from the official website. The only thing users pay is for Arduino hardware.
  - **Multi-platform Environment:** The Arduino IDE is multiplatform software that can run on several platforms including Microsoft, Linux, and Mac OS X making the user community even larger.

### Arduino boards classification

The Arduino boards are classified as Uno, Mega, Lily Pad and Nano as stipulated in [25].

#### a. Arduino UNO

Arduino is open-source electronics prototyping platform based on flexible, easy-to-use hardware and software. It's intended for artists, designers, hobbyists, and anyone interested in creating interactive objects or environments [26].

## **b. Arduino Mega**

The Arduino Mega 2560 is a microcontroller board based on the ATmega2560 (datasheet). It has 54 digital input/output pins (of which 14 can be used as PWM outputs), 16 analog inputs, 4 UARTs (hardware serial ports), a 16 MHz crystal oscillator, a USB connection, a power jack, an ICSP header, and a reset button [27].

## **c. Arduino Lilypad**

Lily Pad is a wearable combination of Arduino that helps create interactive textiles or e-textiles (electronic textiles) Lilypad Arduino Simple has an ATmega328 microprocessor controller at its core. The features of Lilypad Arduino Simple are the following: 5 I/O digital pins ,4 analog pins, ATmega328p microcontroller, LED on pin 13, On/Off switch, Onboard JST connector for charging circuit and 3.7V LiPo battery [28]Arduino lily Pad is designed for e-textiles and wearables projects and can be sewn to fabric and to power supplies [25].

## **d. Arduino Nano**

Arduino Nano is the first embedded microcontroller in the Nano series with many input/output pins, which gives the advantage of utilizing several serial communications like UART, SPI and I2C. It has high performance and low power capabilities. The hardware is compatible with Arduino IDE, Arduino CLI and web editor [29].

The Arduino Nano is a small, complete, and breadboard-friendly board based on the ATmega328 (Arduino Nano 3.x).

## **2.11 Node MCU**

### **2.11.1 Definition:**

The Node MCU (Node Microcontroller Unit) is referred to an open-source software and hardware development environment for IOT that is built around a very inexpensive System-on-a-Chip (SoC) called the ESP8266. The ESP8266, designed and manufactured by Espressif Systems, contains all crucial elements of the modern computer: CPU, RAM, networking (WiFi), and even a modern operating system and SDK [30]. ESP8266 module consists of a built in USB connector and a rich assortment of pinouts. Its micro-USB cable enables its connection with a laptop and flash it without any trouble, just like Arduino. It is also immediately breadboard friendly.

### **2.11.2 Advantages of Node MCU**

The following are advantages of Node MCU platform relative to the Arduino as per [30]:

- Low cost
- Integrated support for WIFI network
- Reduced size of the board
- Low energy consumption

### **2.11.3 Comparison between Arduino and Node MCU**

The following characteristics found important for comparing Arduino and Node MCU as per [30]:

1. Node MCU is having 4MBytes of ROM (flash) and Arduino UNO is just 32 KB,
2. Node MCU can store more code compared to Arduino UNO.
3. Node MCU comes with micro-USB port and Arduino UNO comes with USB type B connector, micro-USB cable is easily available compared to USB type B.
4. Node MCU development board is smaller in size compared to Arduino UNO.
5. Node MCU and Arduino UNO are priced almost the same, so you can opt to buy Node MCU.

## **2.12 A display device**

### **2.12.1 Definition**

A display device is an output device for presenting information in visual or tactile form (the latter used for example in tactile electronic displays for blind people).

If the input information that is supplied has an electrical signal the display is called an electronic display.

### **2.12.2 Liquid crystal display device**

Liquid-crystal display (LCD) is a flat-panel display or any other electronically modulated optical device which uses the light-modulation properties of liquid crystals in combination with polarizers.

LCD are classified in different types. The following are some of them:

### **2.12.3 6X2 alphanumeric LCD.**

LCD is used in most electronic projects in which the status of process can be displayed. The most used module of LCD is the 16X2 alphanumeric LCD.

### **2.12.4 I2C interface 20x4 LCD display module**

The I2C interface 20x4 LCD display module is a new high-quality 4 line 20-character LCD module with on-board contrast control adjustment, backlight and I2C communication interface. For Arduino beginners, no more cumbersome and complex LCD driver circuit connection. The real significant advantages of this I2C Serial LCD module will simplify the circuit connection, save some I/O pins on Arduino board, simplified firmware development with widely available Arduino library [31].

Features of I2C interface 20x4 LCD:[31]

- Compatible with Arduino Board or other controller board with I2C bus.
- Display Type: Black on yellow green backlight.
- I2C Address:0x38-0x3F (0x3F default)
- Supply voltage: 5V
- Interface: I2C to 4bits LCD data and control lines.
- Contrast Adjustment: built-in Potentiometer.
- Backlight Control: Firmware or jumper wire.
- Board Size: 98x60 mm (about 2.36 in).

## **2.13 Breadboard**

### **2.13.1 Definition**

It is a solderless construction base, used for wiring projects with microcontroller boards and developing an electronic circuit.

## **2.14 Printed Circuit Board**

### **Definition**

A printed circuit board (PCB) is any board made for connecting electronic components together. These are used in almost all computers and electronic projects today.

## **2.15 A switch**

### **2.15.1 Definition**

A switch is any electrical device used to interrupt the flow of electrons in a circuit. Switches are fundamentally binary devices: they are either completely on (“closed”) or completely off (“open”). The switches exist in different types however one is selected according to its application.

### **2.15.2 A push button switch**

A pushbutton switch is one of the switch types and it is a two-position device actuated with a button that is pressed and released. Mostly pushbutton switches have a built-in spring mechanism returning the button to its “out,” or “unpressed,” position, for temporary operation.

### **3 Methods and Materials**

#### **3.1 Methods**

##### **3.1.1 Data collection methods**

The project work entails different techniques for the gathering of significant data serving for project design, prototype development and testing. Data collection comprises different techniques using internet resources which include searching and reading different literature from various research websites, publications, eBooks, journals and articles. During prototype testing it was found significant sampling different test users to benchmark the accuracy and repeatability of developed prototype in comparison with existing tape measure and weighing scale results.

##### **3.1.2 Sampling methods**

Different individual samples were needed to test the prototype. Samples measurements were identified using respectively developed prototype; and tape measure and weighing scale.

A simple random sampling method was used to gather population samples. 50 samples were taken randomly from Bugesera district , Mayange sector , Kagenge cell , Biryogo cell (specifically at Biryogo market).

##### **3.1.3 Population**

The used 50 samples of test users were selected among the attendants of Biryogo Market located in Bugesera district , Mayange sector , Kagenge cell , Biryogo cell.

#### **3.2 Materials design**

##### **3.2.1 BMI based monitoring system requirements**

A BMI based monitoring system for obesity early diagnosis aims at determining individual BMI as key metric for personal obesity diagnosis. The recorded BMI data may help the user with obesity management through taking required actions.

To respond to the user needs, the system design requires specific sensors to detect individual height and weight; the detected body parameters data should be processed by the suitable microcontroller notably Node MCU to have the user height and weight data for obesity early diagnosis and management. Node MCU record the user

data which is stored to the remote server for further health conditions management. The user interface was designed to display the system information to the user on the portal.

### **Sensor requirements**

The system requires weight and height sensors to detect the system primary data; however, the sensors should work properly due to their specifications. To meet the expected user needs, the following features are significant:

#### ➤ **Load cell measurement ability**

BMI based monitoring system can use a load cell of loading capacity of 200kg to support a person whose weight is less than 200Kg. The load cell should be fixed at one end to prevent uncertainties in measurements. The load cell accuracy will be verified by comparing its weight measurements to that of other weighing scale or taking a series of measurements for one same individual and compare the measurement results. The precision will be in grams.

#### ➤ **Load cell calibration**

The load cell is to be calibrated using a calibration program. The calibration program serves to find the calibration factor which needs to be entered in the weight measurement program. The calibration factor is a determinant of the accuracy of the weight measurement.

#### ➤ **Ultrasonic sensor**

The BMI based monitoring system uses ultrasonic sensor to determine the position of the standing user from its placement. For the best ultrasonic sensor precision, the system user should remain stable to enable the reflection of sound waves by the user' head. The user needed ultrasonic sensor precision is 3mm (about 0.12 in).

#### ➤ **Environment conditions adaptability**

The BMI based monitoring system should be designed with the ability to adapt to working conditions of temperature and humidity to maintain the measurements accuracy as per load cell technical specifications in [32].

### 3.2.2 Microcontroller requirements

The body mass index-based monitoring device for obesity early diagnosis requires a suitable microcontroller with well-designed embedded software to ensure interoperability among the system components as well the functioning of an entire system.

### System physical dimensions

The designed system expected layout and dimensions are as per following Figure of number 3-1.

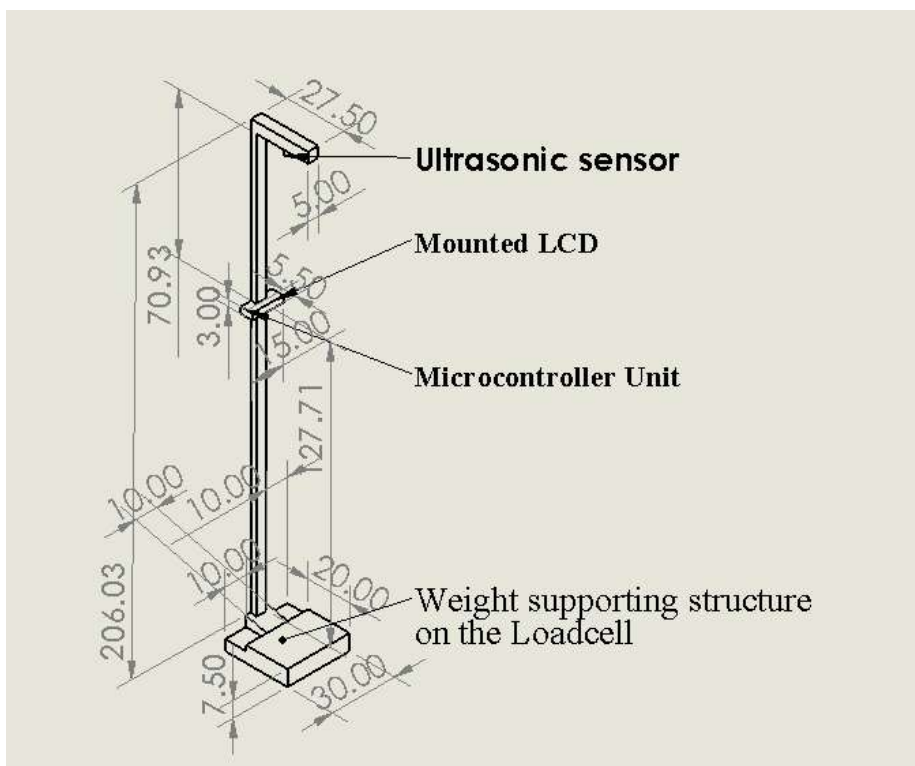

**Figure 3-1 System physical dimensions**

### 3.2.3 Choosing project components

This project requires software and hardware components.

#### Hardware components selection

The project hardware comprises:

- **Microcontroller:** A microcontroller is a small, low-cost and self-contained computer-on-a-chip that can be used as an embedded system for specific tasks. Node MCU ESP8266 microcontroller has been selected over Arduino for BMI based monitoring system use due to its ability to interact with environment using ultrasonic sensor and load cell to detect respectively individual height and weight data; share the captured data to the server for further analysis and storage. Node MCU ESP8266 has many pins supporting easily mount on the printed circuit board and interconnection with other equipment.
- **A weight sensor (of 200kg capacity)** also known as a load cell is an electro-mechanical sensor used to measure force or weight. It has a simplified effective design which relies upon the well-known transference between an applied force, material deformation and the flow of electricity. Load cell is chosen as mass sensor. Load cells are very frequently used for force measurement. It uses flexible load-bearing components or component combinations. The force applied to the elastic element causes it to flex, which is then sensed by the auxiliary sensor, which converts it into a measurable output [33].
- **Height sensor:** it provides outstanding non-contact range detection with high precision and reliable readings easily used. Ultrasonic sensor is chosen as height sensor. It comes complete with an ultrasonic transmitter and receiver module [34]. Ultrasonic sensors work by transmitting a pulse of sound, much like sonar detectors, outside the range of human hearing. This pulse travels away from the range finder in a conical shape at the speed of sound (340 m/s). The sound reflects off an object and back to the range finder. The sensor interprets this as an echo and calculates the time interval between sending the signal and receiving the echo [20].
- **System information display:** the BMI monitoring system displays the user's needs information (height, weight and BMI with obesity status). The I2C LCD is chosen over the other displays due to its features as stated in the following lines. Liquid Crystal display (LCD) is referred to a flat panel display which is used to display images of low content information. It is low cost, programmable easily and able to display many characters. As well an I2C interface 16x2 LCD display module is of a high-quality 2-line 16-character LCD module with on-board contrast control adjustment, backlight and I2C communication interface [35].

- **A switch:**

It is required to control the system operation, power consumption of the system and minimize the microcontroller heating which may affect the system performance. To that extent, a switch is found significant to fulfill all stated roles for the system functioning properly.

- **The supporting structure:**

The project system requires a wooden structure to support other hardware components to enable the expected system function. A part of a wooden structure covers a load cell and supports the user weight when the system is under operation while other part supports ultrasonic sensor, microcontroller unit and display unit.

- **System components connection:**

For components connection, there is a need for a board. Printed circuit board (PCB) was preferred on the final prototype however during testing breadboard is to be used.

PCB is a non-conductive material with printed or etched conductive lines forming a place to mount the components and it provides the means of electrical connection between the components to form a functioning circuit or assembly [36]. Soldering tin is used to join system components to the printed circuit board.

**Hardware components arrangement:**

**a. Project block diagram**

The project components are arranged in different blocks according to the functionality as presented in Figure below 3-2:

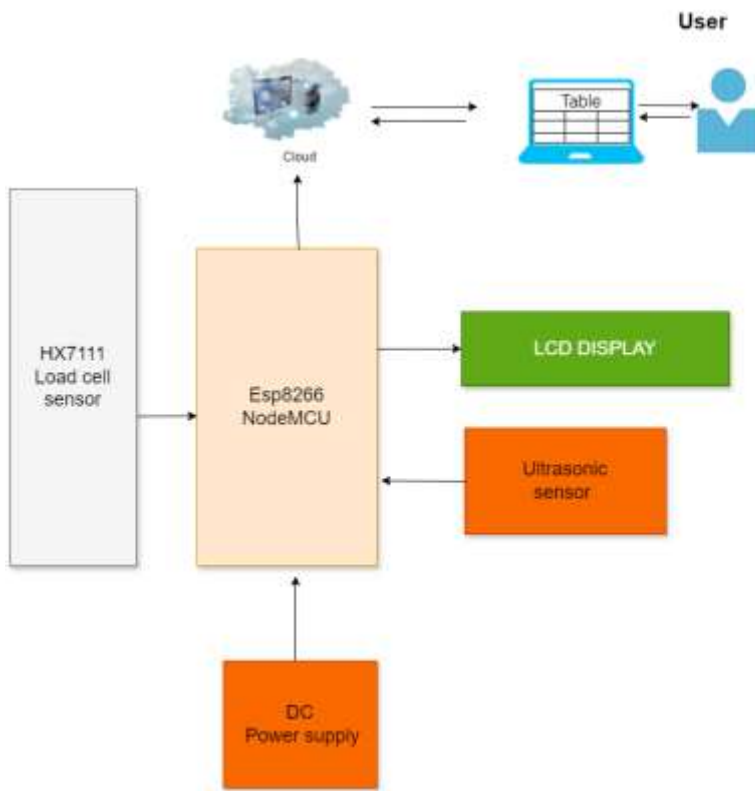

**Figure 3-2 Project block diagram**

**b. Project circuit design**

The project circuit was designed by simulating the interconnection of the system components. The simulated components interconnection results in a circuit diagram. The circuit simulation was drawn using fritzing software. The project circuit is presented in Figure below 3-3.

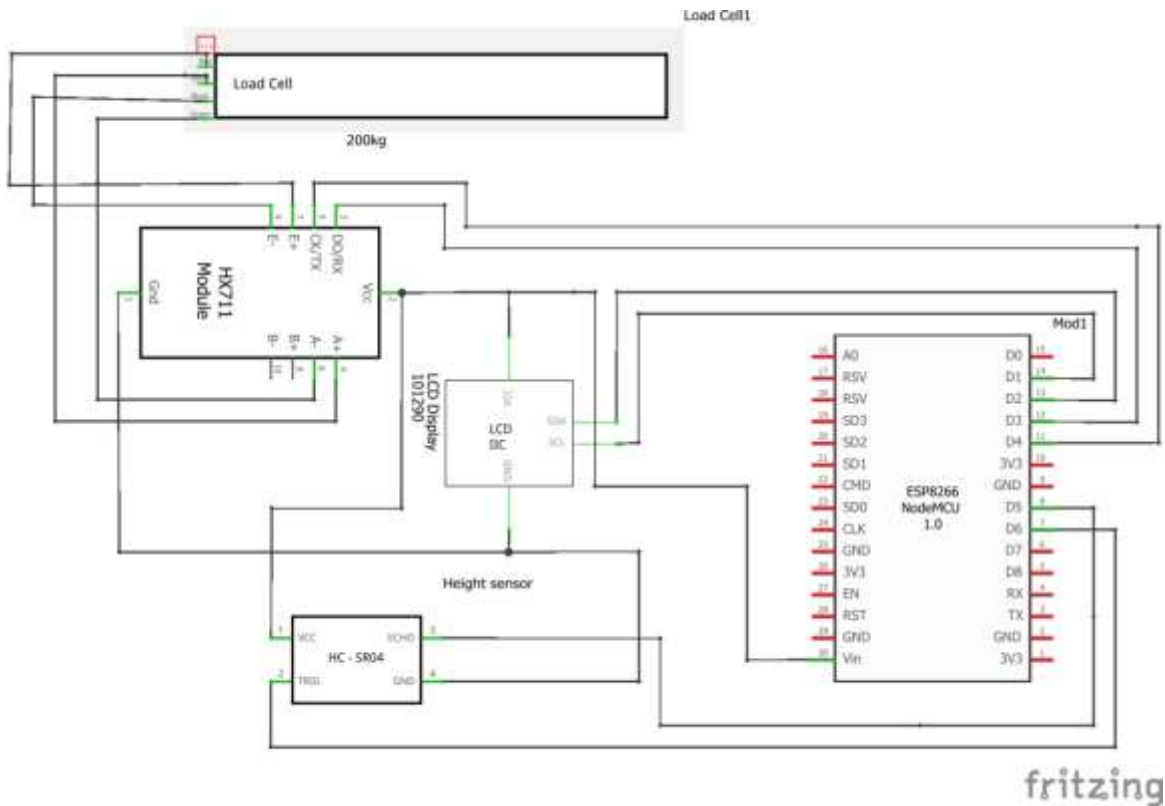

**Figure 3-3 Project circuit diagram**

**c. Project working principle**

The working principle of the project circuit is based on the integration of various hardware components (sensing parts, the execution of software logic by the Node MCU ESP8266 and display of expected results however the results may be retrieved from the server). Here's a detailed explanation of how the circuit operates:

- **Weight sensor operation:**

The weight sensor, namely load cell measures the force applied by a person standing on it. This force is translated into an electrical signal proportional to the detected body weight.

The HX711 module known as load cell amplifier helps to detect any small modification for weight on load cell, amplifies and digitizes it to make it suitable to be processed by the Node MCU ESP8266.

- **Ultrasonic Sensor Operation:**

Normally, ultrasonic sensor emits high-frequency sound pulses and measures the time it takes for these pulses to bounce back after hitting the obstacle or object.

For BMI based monitoring system operation, ultrasonic sensor mounted on the system top transmits sound waves colliding with the head of a user standing on the system reserved position, following the collision, the sound waves bounce and received back by ultrasonic sensor. By measuring the time difference between sending and receiving the sound pulses, the ultrasonic sensor calculates the distance from its placement to the person's head. The found distance serves to calculate the user height through subtracting it from distance between user's feet and ultrasonic sensor position.

- **Node MCU Processing:**

In this project, the Node MCU ESP8266 serves as the control unit of the system. It reads data from the load cell and ultrasonic sensors, processes data to perform calculations determining the BMI of the system user.

All logic and arithmetic operations are performed by the Node MCU ESP8266 with respect to the instructions in its firmware, including BMI calculation achieved using the following formula:  $BMI = \text{weight (kg)} / (\text{height (m)} * \text{height (m)})$ . This formula determines the person's body mass index based on his/her weight and height data which is synchronized using the program instructions. In addition, Node MCU ESP8266 sends the user data to the remote server for easy storage and further management.

- **LCD Display Output:**

The measured user weight, height, BMI value and obesity status are displayed on the LCD screen. This provides immediate feedback to the user about their body mass index. Additionally, the weight is indicated in kilograms, height in meters and the obesity status is expressed by notifying if the user is underweight, normal or overweight on the LCD.

- **User Interaction:**

The user interacts with the system by standing on the weight sensor under the hung ultrasonic sensor.

The system prompts the user through the LCD display, providing feedback following the measurement process. Overall, the BMI monitoring system circuit operates by collecting weight and height measurements using the weight sensor and ultrasonic sensor, respectively. The Node MCU ESP8266 uses this data to calculate the BMI value, which is then displayed on the LCD for the user's information but also the user data is stored on the remote server for future consultation.

### **Software component:**

The body mass index monitoring system comprises embedded software which is significant to interact with system hardware to meet the system user needs. The software component design consists of functional code enabling the microcontroller to read the data from sensors, process data to respond to the user needs and display results as well as storing results to the remote server for further management.

Initially, system software calls upon the user to use BMI based monitoring system through the user interface (either LCD or system dashboard). The software execution results are notified on the LCD playing the role of system user interface.

### **System flow chart**

Figure below 3-4 is about the system flowchart where firstly the system is initialized, then read data from sensors (load cell and ultrasonic sensors) process the data to find BMI which is allocated in the suitable range to determine the obesity status and displays the measured parameters (mass, height, BMI and obesity status) on LCD.

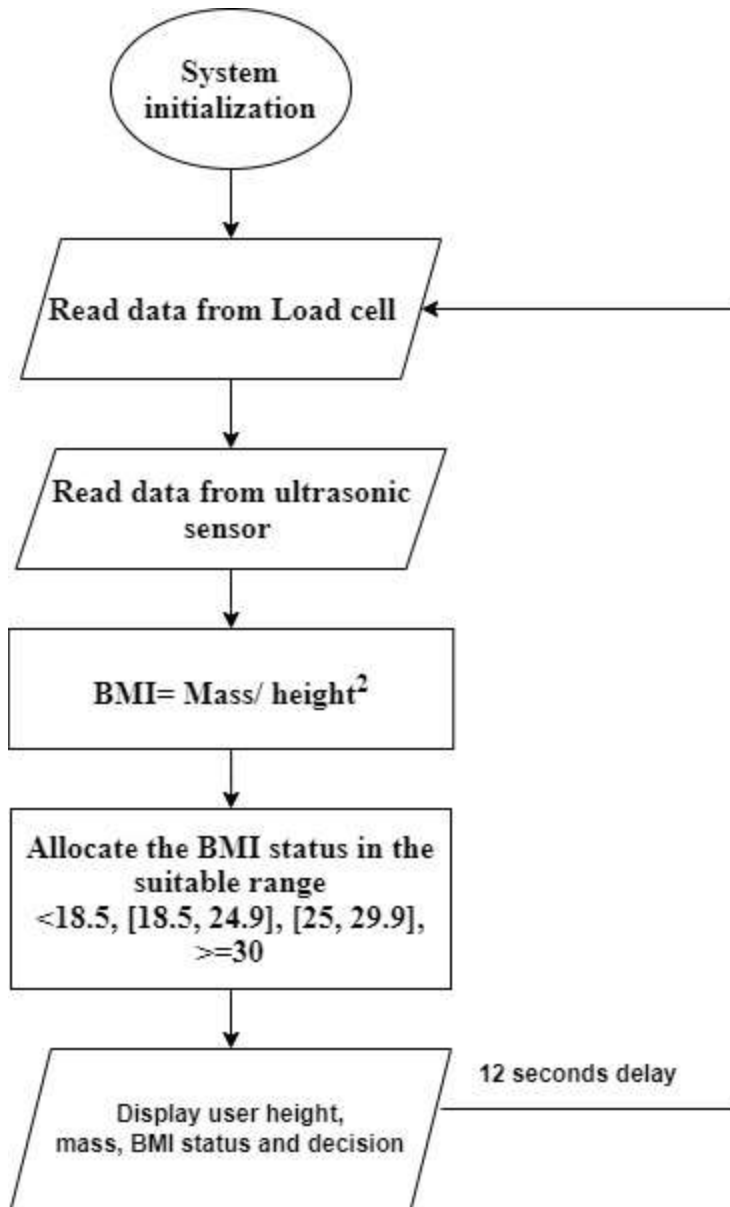

**Figure 3-4 system flow chart**

→ Stands for process path in Figure above

### **BMI monitoring system dashboard design**

The system dashboard was designed to enable access to the data stored on the remote server for obesity management.

The dashboard consists of a login page as shown in the following Figure numbered 3-5

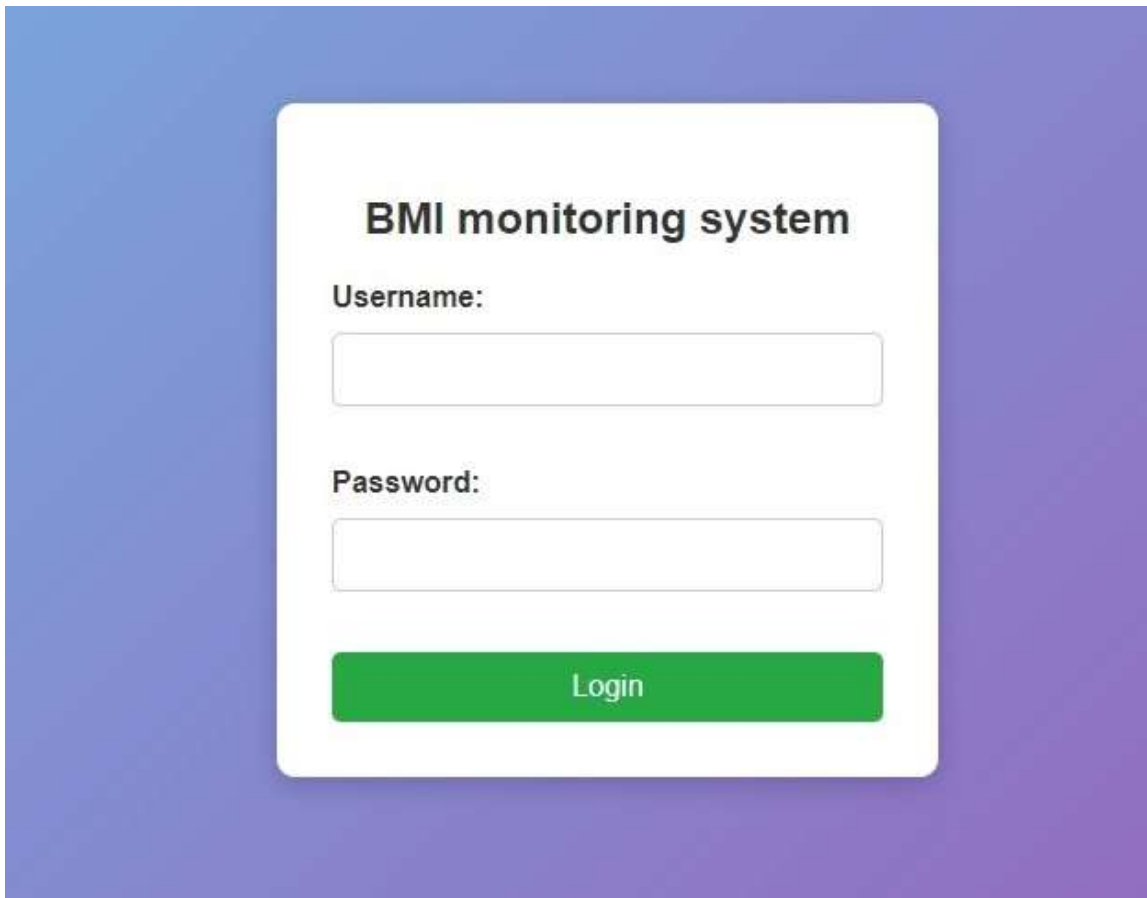

**Figure 3-5 system login page**

The below Figure of number 3-6 is about the appearance of system dash board with a list of cloud stored measurement data records.

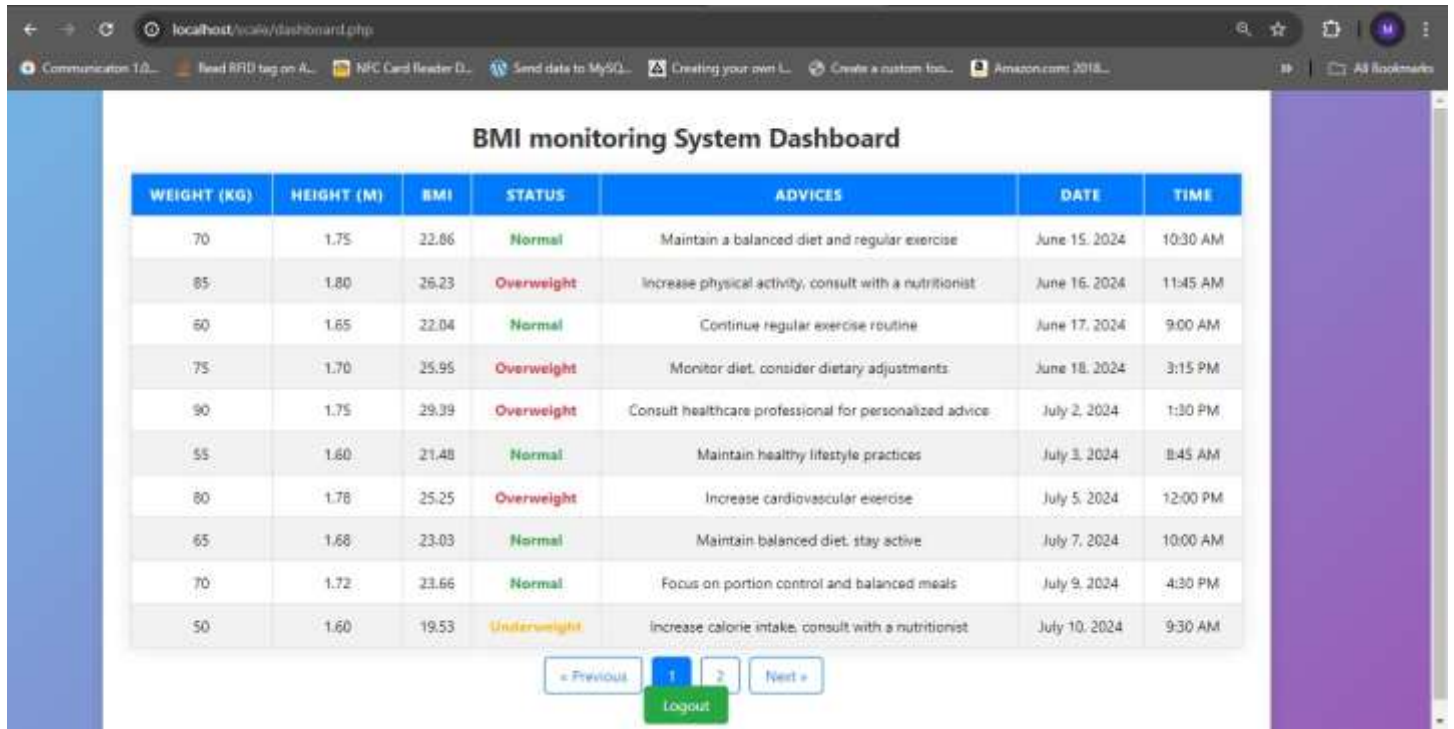

The screenshot shows a web browser window displaying a BMI monitoring system dashboard. The dashboard features a table with columns for Weight (kg), Height (m), BMI, Status, Advices, Date, and Time. The table contains 10 rows of data, with status values ranging from Normal to Underweight. Below the table, there are navigation buttons for 'Previous', '1', '2', and 'Next', along with a 'Logout' button.

WEIGHT (KG)	HEIGHT (M)	BMI	STATUS	ADVICES	DATE	TIME
70	1.75	22.86	Normal	Maintain a balanced diet and regular exercise	June 15, 2024	10:30 AM
85	1.80	26.23	Overweight	Increase physical activity, consult with a nutritionist	June 16, 2024	11:45 AM
60	1.65	22.04	Normal	Continue regular exercise routine	June 17, 2024	9:00 AM
75	1.70	25.95	Overweight	Monitor diet, consider dietary adjustments	June 18, 2024	3:15 PM
90	1.75	29.39	Overweight	Consult healthcare professional for personalized advice	July 2, 2024	1:30 PM
55	1.60	21.48	Normal	Maintain healthy lifestyle practices	July 3, 2024	8:45 AM
80	1.78	25.25	Overweight	Increase cardiovascular exercise	July 5, 2024	12:00 PM
65	1.68	23.03	Normal	Maintain balanced diet, stay active	July 7, 2024	10:00 AM
70	1.72	23.66	Normal	Focus on portion control and balanced meals	July 9, 2024	4:30 PM
50	1.60	19.53	Underweight	Increase calorie intake, consult with a nutritionist	July 10, 2024	9:30 AM

Figure 3-6 System interface showing user data in the cloud

### 3.3 Materials implementation

#### 3.3.1 Hardware mounting and connection

##### Wiring Connections

We will establish the necessary wiring connections between the Node MCU and the sensors. This includes connecting the weight sensor and ultrasonic sensor to appropriate analog and digital pins of the Node MCU. Additionally, connections for power and ground will be made to ensure proper functioning of the components. Figure below of number 3-7 is of mounted Node MCU and HX711 on the PCB.

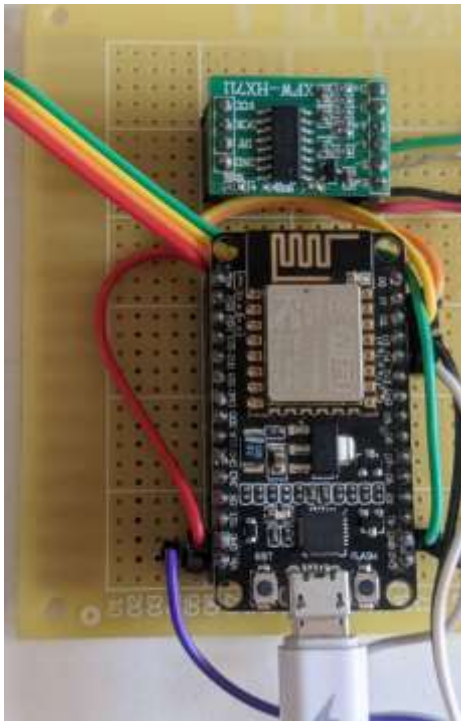

**Figure 3-7 Mounted Node MCU and HX711 module**

The below Figure of number 3-8 present Microcontroller and HX711 module mounted on PCB with a switch to control the system power.

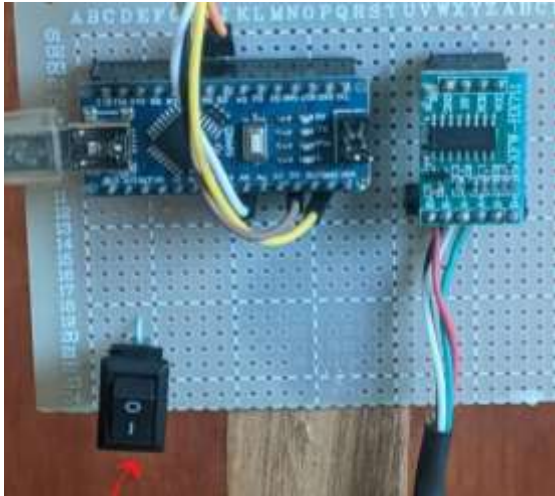

**Figure 3-8 Mounted microcontroller, HX711 module with a switch to control the system power.**

The following Figure numbered 3-9 is about mounted I2C LCD which displays the processed data:



**Figure 3-9 Mounted I2C LCD**

## Mounting Sensors

The sensors are securely mounted on a stable platform namely wood platform to ensure stability and accuracy during measurements. The weight sensor platform presented in Figure below 3-10 is constructed to support varying weights, while the ultrasonic is for height measurement and it is mounted on the top of the system.



**Figure 3-10 weight sensor supported under wooden structure**

The ultrasonic sensor transmits sound waves colliding with the head of a user standing on the system reserved position. Following the collision, the sound waves bounce and received back by ultrasonic sensor. By measuring the time difference between sending and receiving the sound pulses, the ultrasonic sensor calculates the distance from its placement to the person's head. The found distance serves to calculate the user height through subtracting it from distance between user's feet and ultrasonic sensor position. the user height through subtracting it from distance between user's feet and ultrasonic sensor position. Figure below 3-11 is for ultrasonic sensor mounted on a wooden structure.



**Figure 3-11 mounted ultrasonic sensor on wooden structure**

Weight bearing wood structure is fixed tightly to maintain user stability. Figure below 3-12 shows the weight wooden supporting structure where the load cell is fixed. The structure is to support system user stands.



**Figure 3-12 Weight wooden supporting structure**

### **Whole prototype development**

By assembling the above stated parts, the whole prototype was developed as shown in Figure below 3-13:



**Figure 3-13 the whole developed prototype in unfolded (a) and folded forms (b) &(c) respectively**

### **3.3.2 Software Development**

#### **Arduino Firmware Development**

Using the Arduino IDE, we wrote the firmware code for the Node MCU ESP8266. For BMI based monitoring system, this firmware consists of a section reading data from sensors, a section of processing data into user needs including BMI calculation, and a section displaying user measurement parameters using LCD. The code is structured to efficiently handle sensor inputs, perform real-time calculations, and update the LCD display with a individual mass, height, BMI value and obesity status.

#### **Firmware code compiling and debugging**

Following the firmware development, the code is to be compiled. The compiling process translates human-readable code (source code) into machine-readable code (machine code). Compiling could not be successful if there are some errors. Debugging is done prior to compiling process to remove program errors.

#### **Firmware uploading**

Following firmware compiling and debugging, the code is uploaded to the Arduino nano microcontroller using USB cable. Thereafter, the microcontroller may work the expected user function through interacting with other hardware.

The developed codes alongside with the comments are represented in the Appendix

### **3.3.3 Prototype working verification**

#### **Measuring user parameters**

Following the code upload, the prototype working is verified. Verifying the prototype, the user stands upright on the designed wood stands and faces LCD to oversee the measured parameters. Prototype working verification is done by comparing the measurements received from the implemented system with that observed using a weighing scale and tape measure to determine respectively user weight and height as shown in Figure below 3-14:



**Figure 3-14 Prototype working verification**

**Prototype performance verification results**

Table 1 is about the results found using weighing scale and tape measure respectively to measure weight and height from then finding BMI by calculations and results observed using BMI monitoring system prototype for 50 Test Users: from Test User1, Test User2, Test User3, ..... up to Test User 50.

**Table 1: Results observed for weighing scale and tape measure measurements and those found from BMI monitoring system**

Test user No	Measured Weight ( in Kg) using weighing scale	Measured Weight ( in Kg) using BMI monitoring system prototype	Difference in weight measurement (Kg)	Measured Height ( in metres) using tape measure	Measured Height ( in metres) using BMI monitoring system prototype	Difference in height measurement (m)	Calculated BMI	BMI found using BMI monitoring system prototype	Corresponding Obesity Status for both measurement cases
1	76.5	76.8	-0.3	1.66	1.67	-0.01	27.8	27.8	Overweight
2	59.4	59.42	-0.02	1.7	1.78	-0.08	20.6	20.6	Normal weight
3	65.35	65.3	0.05	1.76	1.75	0.01	21.1	21.0	Normal weight
4	78.98	78.96	0.02	1.82	1.82	0	23.8	23.6	Normal weight

5	65.51	65.53	-0.02	1.8	1.81	-0.01	20.2	20.0	Normal weight
6	79.4	79.6	-0.2	1.7	1.72	-0.02	27.5	27.4	Overweight
7	69.51	69.65	-0.14	1.66	1.65	0.01	25.2	25.1	Overweight
8	80.2	80.31	-0.11	1.7	1.7	0	27.8	27.7	Overweight
9	75.38	75.49	-0.11	1.76	1.77	-0.01	24.3	24.4	Normal weight
10	59.45	59.6	-0.15	1.82	1.8	0.02	17.9	18.0	Under weight
11	77.52	77.68	-0.16	1.8	1.81	-0.01	23.9	24.0	Normal weight
12	58.38	58.35	0.03	1.7	1.68	0.02	20.2	21.4	Normal weight
13	65.45	65.48	-0.03	1.66	1.64	0.02	23.8	23.9	Normal weight
14	78.98	78.9	0.08	1.7	1.72	-0.02	27.3	27.5	Overweight
15	65.62	65.58	0.04	1.76	1.77	-0.01	21.2	21.1	Normal weight
16	79.48	79.6	-0.12	1.82	1.81	0.01	24.0	24.2	Normal weight
17	69.5	69.65	-0.15	1.8	1.8	0	21.5	21.6	Normal weight
18	81.2	81.31	-0.11	1.7	1.68	0.02	28.1	28.0	Overweight
19	75.38	75.49	-0.11	1.66	1.67	-0.01	27.4	27.5	Overweight
20	59.45	59.6	-0.15	1.7	1.71	-0.01	20.6	20.7	Normal weight
21	76.5	76.82	-0.32	1.76	1.77	-0.01	24.7	24.6	Normal weight
22	59.4	59.43	-0.03	1.82	1.83	-0.01	17.9	17.9	Under weight
23	65.35	65.3	0.05	1.8	1.79	0.01	20.2	20.1	Normal weight
24	78.98	78.96	0.02	1.72	1.7	0.02	26.7	26.8	Overweight
25	65.51	65.53	-0.02	1.52	1.56	-0.04	28.4	28.5	Overweight
26	79.4	79.6	-0.2	1.72	1.73	-0.01	26.8	26.7	Overweight
27	69.51	69.65	-0.14	1.6	1.59	0.01	27.2	27.3	Overweight
28	80.2	80.31	-0.11	1.73	1.72	0.01	26.8	26.9	Overweight
29	75.38	75.49	-0.11	1.68	1.66	0.02	26.7	26.8	Overweight
30	59.45	59.6	-0.15	1.68	1.69	-0.01	21.1	21.0	Normal weight

31	76.52	76.8	-0.28	1.69	1.67	0.02	26.8	26.8	Overweight
32	59.39	59.42	-0.03	1.58	1.59	-0.01	23.8	23.3	Normal weight
33	65.38	65.32	0.06	1.52	1.5	0.02	28.3	28.4	overweight
34	78.98	78.96	0.02	1.67	1.67	0	28.3	28.2	overweight
35	66.51	66.53	-0.02	1.5	1.51	-0.01	29.6	29.4	overweight
36	79.4	79.6	-0.2	1.71	1.7	0.01	27.2	27.4	overweight
37	69.6	69.65	-0.05	1.68	1.69	-0.01	24.7	24.8	Normal weight
38	80.2	80.31	-0.11	1.65	1.66	-0.01	29.5	29.6	Overweight
39	75.38	75.49	-0.11	1.69	1.7	-0.01	26.4	26.5	Overweight
40	59.54	59.6	-0.06	1.6	1.62	-0.02	23.3	23.4	Normal weight
41	76.5	76.8	-0.3	1.6	1.65	-0.05	29.9	29.8	Overweight
42	58.4	59.42	-1.02	1.65	1.66	-0.01	21.5	21.6	Normal weight
43	66.35	66.4	-0.05	1.58	1.59	-0.01	26.6	26.7	Overweight
44	78.98	78.96	0.02	1.66	1.68	-0.02	28.7	28.5	Overweight
45	65.51	65.53	-0.02	1.55	1.57	-0.02	27.3	27.2	Overweight
46	79.4	79.6	-0.2	1.72	1.7	0.02	26.8	26.9	Overweight
47	69.51	69.65	-0.14	1.62	1.61	0.01	26.5	26.6	Overweight
48	80.2	80.31	-0.11	1.71	1.72	-0.01	27.4	27.3	Overweight
49	75.38	75.49	-0.11	1.67	1.69	-0.02	27.0	27.1	Overweight
50	60.45	60.6	-0.15	1.56	1.54	0.02	24.8	24.7	Normal weight

The sample of 50 test users selected randomly to evaluate BMI monitoring system prototype performance. Comparing results from manual measurements and those observed from BMI monitoring system prototype, some deviations were found notably the maximum deviation of **0.32** units for weight and that of **0.04** units for height however the obesity status of tested individual remains the same for both measurement types.

To maintain the results accuracy and repeatability of BMI monitoring system, the user is recommended to stand upright and remain stable on the load supporting structure and try to minimize the floor unevenness.

Figure below numbered 3-15 is about the graph displaying Measured weight using weighing scale against measured weight using BMI monitoring system prototype.

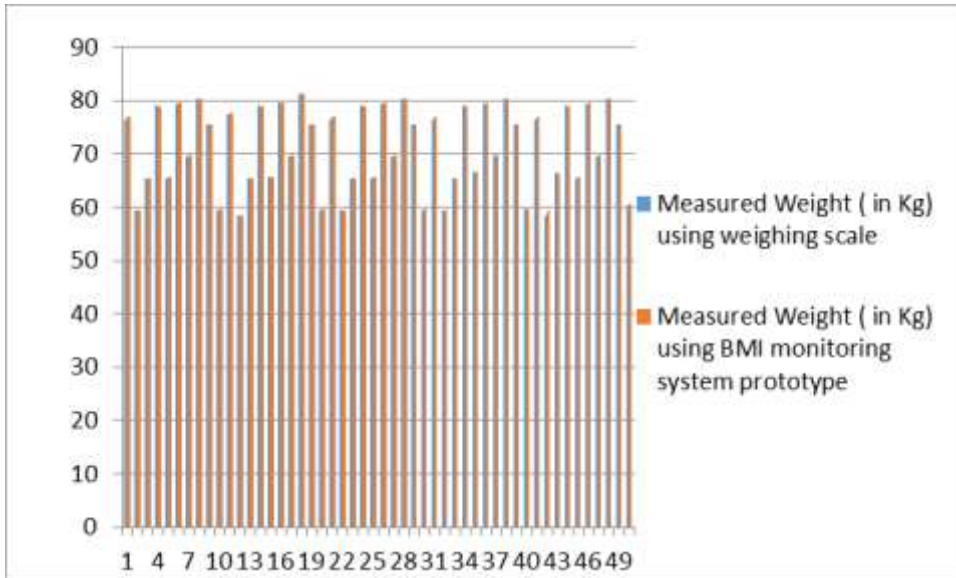

**Figure 3-15 Measured weight using weighing scale against measured weight using BMI monitoring system prototype**

Figure below number 3-16 displays the graph of measured height using weighing scale against measured height using BMI monitoring system prototype.

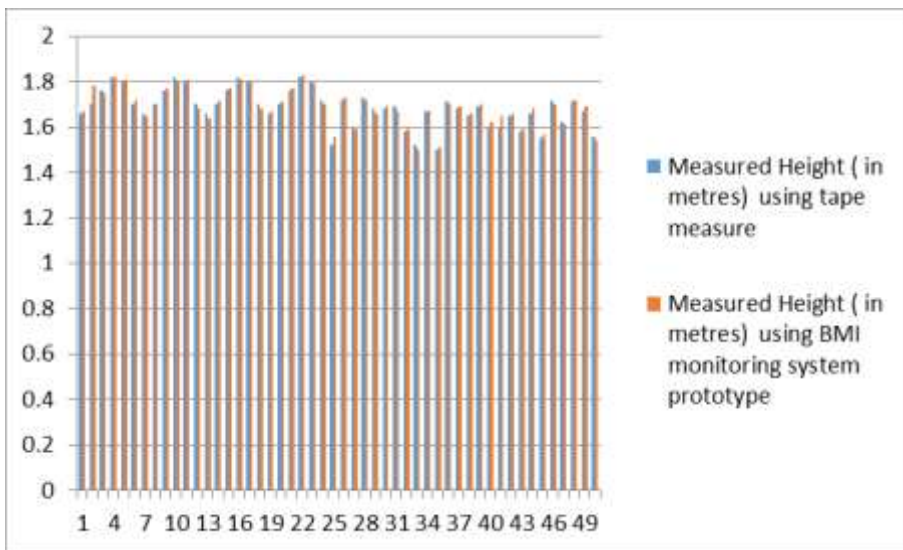

**Figure 3-16 Measured height using weighing scale against measured height using BMI monitoring system prototype**

The following Figure with number 3-17 displays the Difference observed in weight measurement versus difference in height measurement

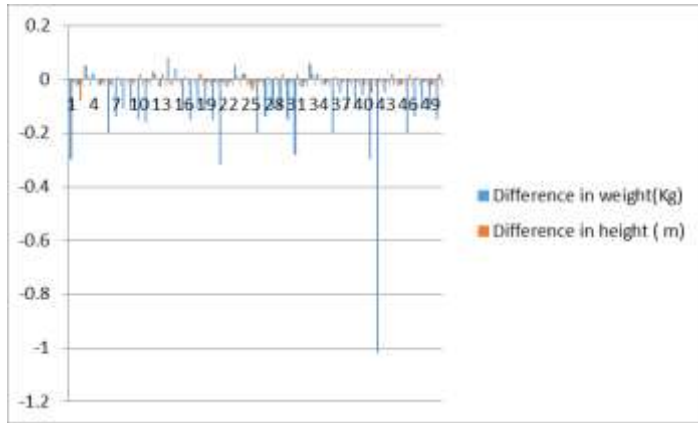

**Figure 3-17 Difference in weight versus difference in height**

### Measurement initialization

When the system is turned on initially, it shows the screen presented in the Figure below 3-18 marks the parameters to be measured:



**Figure 3-18 Measured parameters presentation in initial state**

### **Measured Parameters presentation and obesity status identification**

During testing the developed prototype was used to test different individuals' obesity status. Their personal body parameters (weight, height and BMI) were measured to identify the obesity status corresponding to the detected body parameters.

Figure below numbered 3-19 and 3-20 show the measured parameters (weight, height and BMI) with the corresponding obesity status.

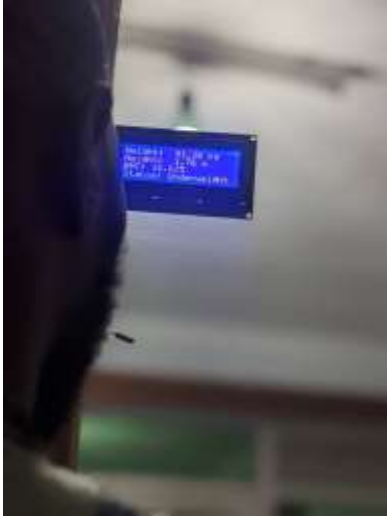

**Figure 3-19 Measured parameters presentation with obesity status of Normal**



**Figure 3-20 Measured parameters presentation with obesity status of overweight**

The following Figure of number 3-21 presents the results of an individual with underweight status



**Figure 3-21 Measured parameters presentation with obesity status of underweight**

## **4 Conclusion and Recommendations:**

### **4.1 Conclusion**

This project entitled” Design and prototyping of Body mass index-based monitoring device for obesity early diagnosis “used the specific design techniques contributed to successful design and development of prototype using body mass index as a key metric for early diagnosis of obesity status following the detection of individual weight and height.

**The following are the project key achievements:**

- **Development of a BMI monitoring prototype:** The project resulted in a developed prototype that attracts users to track their BMI. This can raise public awareness about weight management and potentially motivate individuals to adopt healthier lifestyles through their BMI monitoring.
- **Potential for early detection:** By enabling regular BMI monitoring, the device can contribute to early identification of obesity risk through individual testing. Early intervention can be crucial in preventing obesity-related health complications.
- **Simplified user experience:** The design is to prioritize a user-friendly interface for ease of use and encourage consistent monitoring.

**The following limitations need to be addressed in future research:**

- **Limited scope of obesity diagnosis:** BMI is a valuable initial indicator, but it doesn't account for body composition (muscle mass versus fat). More comprehensive diagnostic tools might be integrated in future versions.
- **Clinical validation:** While the concept holds promise, clinical trials are necessary to validate the device's effectiveness in real-world scenarios.

Overall, this project presents a valuable step towards promoting public awareness on early obesity detection. Further development and testing can transform this prototype into a practical tool for promoting healthy weight management to prevent obesity associated risks.

### **4.2 Recommendations**

- **To Ministry of health:**  
I do recommend Ministry of health in Rwanda:

- ✓ Putting emphasis on raising public awareness on obesity self-monitoring to address the issue of non-communicable diseases related to obesity risk
- ✓ Availing facilities enabling obesity self-monitoring to the public to minimize obesity related chronic diseases
- ✓ Incubate the students with good innovative research projects which may impact the public health and link them with biomedical industries as well as funders for further implementation.

- **To Center of Excellence in Biomedical Engineering and E-Health (CEBE) and University of Rwanda**

I do urge the Center of Excellence in Biomedical Engineering and E-Health (CEBE) to partner with different health organization and private sectors in biomedical engineering domain to facilitate the industrial exposure and professional growth of students pursuing Masters of Science in the biomedical engineering. This may consider regional and international entities in biomedical engineering to train biomedical professionals to adapt the cutting-edge health technologies.

- **To other researchers**

Design and prototyping of body mass index–based monitoring device for obesity early diagnosis provides easy and portable way for obesity self-monitoring considering individual body mass and height however there is a need of improving the developed prototype to adopt the cutting-edge health technologies including tele-health and patient remote monitoring.

## 5 References

- [1] “Health service delivery framework for prevention and management of obesity.”
- [2] T. Omer, “The causes of obesity: an in-depth review,” *Adv Obes Weight Manag Control*, vol. 10, no. 4, pp. 90–94, Jul. 2020, doi: 10.15406/aowmc.2020.10.00312.
- [3] World Health Organization. Regional Office for Europe, *WHO European Regional Obesity : Report 2022*.
- [4] F. Q. Nuttall, “Body mass index: Obesity, BMI, and health: A critical review,” *Nutrition Today*, vol. 50, no. 3. Lippincott Williams and Wilkins, pp. 117–128, May 17, 2015. doi: 10.1097/NT.0000000000000092.
- [5] Nhlbi, “For Adults-Find Your BMI in the Chart on the Reverse Side What does your BMI mean?” [Online]. Available: <http://wecan.nhlbi.nih.gov>
- [6] F. Q. Nuttall, “Body mass index: Obesity, BMI, and health: A critical review,” *Nutrition Today*, vol. 50, no. 3. Lippincott Williams and Wilkins, pp. 117–128, May 17, 2015. doi: 10.1097/NT.0000000000000092.
- [7] M. Murguía-Romero *et al.*, “The body mass index (BMI) as a public health tool to predict metabolic syndrome,” *Open J Prev Med*, vol. 02, no. 01, pp. 59–66, 2012, doi: 10.4236/ojpm.2012.21009.
- [8] S. Kolimechkov, “The Body Mass Index: A Systematic Review Beep Shuttle: Software for Assessing Cardiorespiratory Fitness (20m SRT) View project.” [Online]. Available: <https://www.researchgate.net/publication/342927347>
- [9] G. Bobula, “Influence, Significance and Importance of Body Mass Index in Scientific Research and Various Fields of Science,” *Am J Biomed Sci Res*, vol. 4, no. 4, pp. 287–289, Aug. 2019, doi: 10.34297/ajbsr.2019.04.000816.
- [10] N. Aktar, N. K. Qureshi, and H. S. Ferdous, “Obesity: A Review of Pathogenesis and Management Strategies in Adult,” *Delta Medical College Journal*, vol. 5, no. 1, pp. 35–48, Feb. 2017, doi: 10.3329/dmcj.v5i1.31436.
- [11] CDC, “Body Mass Index: Considerations for Practitioners.” [Online]. Available: <http://apps.nccd.cdc.gov/dnpabmi/>

- [12] A. D. A. Karim, N. A. M. Lazam, N. A. Mohd Yahya, and S. Abdul Rahman, "Portable Real-Time BMI Nutritional Advice," *IOP Conf Ser Mater Sci Eng*, vol. 1176, no. 1, p. 012017, Aug. 2021, doi: 10.1088/1757-899x/1176/1/012017.
- [13] M. Nanak Zakaria and M. El Qibthiyah, "Design Of Monitoring System of Height, Weight and Body Mass Index Using Android-Based Node MCU ESP8266".
- [14] "Hadoop based Obesity Monitoring System."
- [15] F. Amani and P. Amani, "Using Machine Learning Method for classification Body Mass Index for clinical decision", doi: 10.21203/rs.3.rs-250227/v1.
- [16] H. Bipembi, J. Ben Hayfron-Acquah, J. Kobina Panford, O. Appiah, J. B. Hayfron-Acquah, and J. K. Panford, "Calculation of Body Mass Index using Image Processing Techniques Comparative Analysis of Convergence Times between RIP and EIGRP Routing Protocols in a Network View project Designing Algorithm for Malaria Diagnosis Using Fuzzy Logic for Treatment (AMDFLT) in Ghana View project Calculation of Body Mass Index using Image Processing Techniques," 2015. [Online]. Available: <https://www.researchgate.net/publication/280133090>
- [17] B. C. Patel, G. R. Sinha, and N. Goel, "Introduction to sensors," in *Advances in Modern Sensors*, IOP Publishing, 2020. doi: 10.1088/978-0-7503-2707-7ch1.
- [18] A. M A, "Automatic Human Height Detector - A Review," *Int J Res Appl Sci Eng Technol*, vol. 9, no. 1, pp. 846–855, Jan. 2021, doi: 10.22214/ijraset.2021.32954.
- [19] F. Ng, "Ultrasonic Sensors", doi: 10.13140/RG.2.2.33638.78404.
- [20] "Ultrasonic Ranging Module HC-SR04." [Online]. Available: [www.Elec Freaks.com](http://www.Elec Freaks.com)
- [21] V. A. Kamble, V. D. Shinde, J. K. Kittur, and R. Scholar, "Overview of Load Cells," *Journal of Mechanical and Mechanics Engineering*, no. 6, [Online]. Available: [www.matjournals.com](http://www.matjournals.com)
- [22] L. Louis, "Working Principle of Arduino and Using it as a Tool for Study and Research," *International Journal of Control, Automation, Communication and Systems*, vol. 1, no. 2, pp. 21–29, Apr. 2016, doi: 10.5121/ijcacs.2016.1203.
- [23] A. Shakirovich Ismailov Zafar Botirovich Jo, "Study of arduino microcontroller board." [Online]. Available: [www.openscience.uz](http://www.openscience.uz)
- [24] A. Shakirovich Ismailov Zafar Botirovich Jo, "Study of arduino microcontroller board." [Online]. Available: [www.openscience.uz](http://www.openscience.uz)

- [25] D. Ronzani, "Introduction to Arduino," 2017.
- [26] "Arduino® UNO R3."
- [27] "mega\_2560".
- [28] H. Yuksel, "The LilyPad Arduino."
- [29] "Arduino® Nano."
- [30] "Handson Technology User Guide I2C Serial Interface 20x4 LCD Module." [Online]. Available: [www.handsontec.com](http://www.handsontec.com)
- [31] "Load Cell Data Sheet 200kg".
- [32] V. A. Kamble, V. D. Shinde, J. K. Kittur, and R. Scholar, "Overview of Load Cells," *Journal of Mechanical and Mechanics Engineering*, no. 6, [Online]. Available: [www.matjournals.com](http://www.matjournals.com)
- [33] M. J. Alam, B. S. Chowdhury, M. T. Mahmud, F. Soroni, and M. M. Khan, "Development of Smart Height Measuring Scale," in *2021 12th International Conference on Computing Communication and Networking Technologies, ICCCNT 2021*, Institute of Electrical and Electronics Engineers Inc., 2021. doi: 10.1109/ICCCNT51525.2021.9579637.
- [34] "Handson Technology User Guide I2C Serial Interface 1602 LCD Module." [Online]. Available: [www.handsontec.com](http://www.handsontec.com)

## 6 Appendix: Firmware code alongside with comments

```
#include <LiquidCrystal_I2C.h>

#include <HX711.h>

#include <ESP8266WiFi.h>

#include <ESP8266HTTPClient.h>

const char* ssid = "Pixel_8219"; // Replace with your WiFi SSID

const char* password = "eric1125"; // Replace with your WiFi password

const char* serverIP = "192.168.46.119"; // Replace with your XAMPP server's IP or IP of your computer

// Set the LCD address and dimensions (20x4)

LiquidCrystal_I2C lcd(0x27, 20, 4);

// Pin configuration for HX711

const int DOUT_PIN = D6; // Node MCU pin D3 (GPIO 0)

const int SCK_PIN = D5; // Node MCU pin D2 (GPIO 4)

HX711 scale;

// Define pins for ultrasonic sensor

const int trigPin = D3; // Node MCU pin D6 (GPIO 12)

const int echoPin = D4; // Node MCU pin D5 (GPIO 14)

// Variables for duration and distance

long duration;

float distance;
```

```
void setup() {  
  
    // Initialize serial communication  
    Serial.begin(115200);  
  
    connectWiFi();  
  
    // Initialize the LCD  
  
    lcd.init();  
  
    lcd.backlight();  
  
    lcd.clear();  
  
    lcd.setCursor(0, 0);  
  
    lcd.print("BMI monitoring");  
  
    lcd.setCursor(0, 1);  
  
    lcd.print("System");  
  
    // Initialize the HX711  
  
    scale.begin(DOUT_PIN, SCK_PIN);  
  
    // Define trigPin as an output  
    pinMode(trigPin, OUTPUT);  
  
    // Define echoPin as an input  
    pinMode(echoPin, INPUT);  
  
}  
  
void loop() {  
  
    // Clear the trigPin
```

```

digitalWrite(trigPin, LOW);

delayMicroseconds(2);

// Set the trigPin on for 10 microseconds to send the ultrasonic pulse

digitalWrite(trigPin, HIGH);

delayMicroseconds(10);

digitalWrite(trigPin, LOW);

// Measure the duration of the pulse on the echoPin

duration = pulseIn(echoPin, HIGH);

// Calculate the distance in centimeters

distance = duration * 0.034 / 2;

float height = 209.10 - distance;

float height_m = height / 100; // Convert height to meters

// Print the distance to the serial monitor

Serial.print("Height: ");

Serial.print(height_m);

Serial.println(" m");

if (scale.is_ready()) {

    // Read the weight in grams

    float weight = scale.get_units(10); // 10 readings for averaging

    float weight_kg = (((weight / 1000) / 20) - 12) + 20; // Convert weight to kilograms

    // Calculate BMI

```

```
float BMI = weight_kg / (height_m * height_m);

// Display weight and BMI on LCD

if (height_m <= 0.09) {

    lcd.setCursor(0, 0);

    lcd.print(" Check your Weight ");

    lcd.setCursor(0, 1);

    lcd.print(" Check your Height ");

    lcd.setCursor(0, 2);

    lcd.print(" Check your BMI");

    lcd.setCursor(0, 3);

    lcd.print("and Obesity Status ");

}

// Display BMI category

if (BMI < 18.5 && BMI >= 1) {

    lcd.setCursor(0, 0);

    lcd.print("Weight: ");

    lcd.print(weight_kg);

    lcd.print(" kg");

    lcd.setCursor(0, 1);

    lcd.print("Height: ");

    lcd.print(height_m);
```

```
lcd.print(" m");

lcd.setCursor(0, 2);

lcd.print("BMI: ");

lcd.print(BMI);

lcd.setCursor(0, 3);

lcd.print("Status: Underweight");

    sendDataToServer(height_m, weight_kg, BMI);
} else if (BMI >= 18.5 && BMI < 24.9) {

lcd.setCursor(0, 0);

lcd.print("Weight: ");

lcd.print(weight_kg);

lcd.print(" kg");

lcd.setCursor(0, 1);

lcd.print("Height: ");

lcd.print(height_m);

lcd.print(" m");

lcd.setCursor(0, 2);

lcd.print("BMI: ");

lcd.print(BMI);

lcd.setCursor(0, 3);

lcd.print("Status: Normal ");
```

```
    sendDataToServer(height_m, weight_kg, BMI);
} else if (BMI >= 25 && BMI < 29.9) {
    lcd.setCursor(0, 0);
    lcd.print("Weight: ");
    lcd.print(weight_kg);
    lcd.print(" kg");
    lcd.setCursor(0, 1);
    lcd.print("Height: ");
    lcd.print(height_m);
    lcd.print(" m");
    lcd.setCursor(0, 2);
    lcd.print("BMI: ");
    lcd.print(BMI);
    lcd.setCursor(0, 3);
    lcd.print("Status: Overweight");
    sendDataToServer(height_m, weight_kg, BMI);
}
sendDataToServer(height_m, weight_kg, BMI);
delay(12000); // Adjust as needed
} else {
    Serial.println("Error: Unable to detect the HX711 module. Please check your connections.");
```

```

    delay(1000);

}

}

void connectWiFi() {

    WiFi.begin(ssid, password);

    while (WiFi.status() != WL_CONNECTED) {

        delay(500);

        Serial.print(".");

    }

    Serial.println("WiFi connected");

    Serial.print("IP Address: ");

    Serial.println(WiFi.localIP());

}

void sendDataToServer(float height_m, float weight_kg, float BMI) {

    HTTPClient http;

    String url = "http://" + String(serverIP) + "/scale/new.php";

    http.begin(url);

    http.addHeader("Content-Type", "application/x-www-form-urlencoded");

    String postData = "height_m=" + String(height_m) + "&weight_kg=" + String(weight_kg)+ "&BMI=" +
String(BMI);

    int httpResponseCode = http.POST(postData);

    if (httpResponseCode > 0) {

```

```
Serial.print("HTTP Response code: ");  
  
Serial.println(httpResponseCode);  
  
} else {  
  
Serial.print("Error in HTTP request. HTTP Response code: ");  
  
Serial.println(httpResponseCode);  
  
}  
  
http.end();  
  
}
```