



UNIVERSITY of
RWANDA

College of Science and Technology



AFRICAN CENTER OF
EXCELLENCE IN ENERGY FOR
SUSTAINABLE DEVELOPMENT

**FEASIBILITY STUDY AND DESIGN OF SOLAR - WIND HYBRID SYSTEM IN
RWANDA**

By

BARIKUNDA FRANCOIS

Ref. No: 221030658

A dissertation submitted to the African Centre of Excellence in Energy for Sustainable

Development (ACE-ESD)

College of Science and Technology, University of Rwanda in Partial Fulfilment of the Requirement for the
Degree of Master of Science in Electrical Power Systems.

Supervisor: Dr Emmanuel UFITEYEZU

22, November 2023

Kigali-Rwanda

Declaration of Originality

I, BARIKUNDA FRANCOIS, hereby confirm that this thesis is fully my original work. To the best of my knowledge, this work has never been submitted for a degree at another higher education institution.

BARIKUNDA FRANCOIS

November 22, 2023



This thesis has been submitted with an approval as university supervisor:

Dr. Emmanuel UFITEYEZU

November 22, 2023

Dedication

I dedicate this thesis to my beloved wife Odette MUKANDINDA, my mother Marie MUKANSONGA and my Children for their well-wishing and motivating me to put in a lot of effort in my studies. To my family members, I appreciate your prayers and words of support provided. Most importantly, I thank God for all of his blessings every day.

Acknowledgements

First, I give acknowledgment to Almighty God for his graceful and merciful support of Almighty God who gave me a healthy life. Secondly, I sincerely appreciate my dissertation supervisor **Dr. Emmanuel UFITEYEZU** Director of ACE in Energy for Sustainable Development, University of Rwanda, for his incredible encouragement and guidance.

Finally, I express my gratitude to my lecturers and Electrical Power System students in African Center of Excellence in ESD at the University of Rwanda for their academic support, moral guidance and continuous support.

Contents	
Declaration of Originality	ii
Dedication	iii
Acknowledgements	iv
ABBREVIATIONS	viii
LIST OF FIGURES	x
LIST OF TABLES	xii
ABSTRACT	xiii
CHAPTER 1: INTRODUCTION	1
1.1. Background	1
1.2. Problem Statement	1
1.3. Research Objectives	1
1.4. Justification of the Study	2
1.5. Contributions and Gap Addressing	2
1.6. Scope of Work	3
1.7. Literature Review	3
CHAPTER 2: LITERATURE REVIEW	4
2.1. Country Overview: Rwanda	4
2.1.1. Households that use electricity as the main source of lighting	4
2.2. Review of Related Works	5
2.3. SOLAR PHOTOVOLTAIC SYSTEM.	6
2.3.1. SOLAR PANELS	7
2.3.2. Introduction	7
2.3.3. Solar Panels Works Working Principle	7
2.3.4. Types of PV Panels	8
2.3.4.1. Monocrystalline Solar Panels	8
2.3.4.2. Polycrystalline Solar Panels	8
2.3.4.3. Thin-Film Solar Panels	9
2.3.4.4. Bifacial Solar Panels	9
2.3.4.5. Concentrated Solar Panels (CSP)	9
2.3.5. Solar Cell	10
2.3.6. Silicon Cells Working Principal	10
2.3.7. Equivalent solar cell circuit	11
2.4. WIND ENERGY RESOURCE	12
2.4.1. Working of Wind Power System	13
2.4.2. Wind Turbine	16

2.4.2.1.	Horizontal Axis Wind Turbines (HAWTs).....	16
2.4.2.2.	Vertical Axis Wind Turbines	17
2.5.	Identified solutions for remote area electrification.....	17
2.5.1.	Isolated Grid Solution.....	18
2.6.	PV-Wind Hybrid Power System.....	18
2.6.1.	Technical configurations for hybrid power systems	19
2.6.1.1.	AC-coupled Hybrid Power Systems	19
2.6.1.1.1.	Centralized AC-coupled Hybrid Power Systems	19
2.6.1.1.2.	Distributed AC-coupled Hybrid Power Systems.....	20
2.6.1.2.	DC-coupled Hybrid Power Systems	21
2.6.2.	Storage Battery.....	21
2.6.3.	Inverter/ Converters	22
2.6.4.	PV Controllers.....	22
2.7.	Wind Energy Potential in Rwanda.....	23
2.8.	Solar Energy Potential in Rwanda	24
CHAPTER 3: METHODOLOGY.....		24
3.1.	INTRODUCTION.....	24
3.2.	MODELING SOFTWARE: MATLAB SIMULATION	25
3.3.	Gatwa VILLAGE LOAD ESTIMATION.....	25
3.3.1.	Household Load.....	26
3.3.2.	School Load	26
3.3.3.	Cell Building Load	26
3.3.4.	Commercial Load.....	27
3.3.5.	Total Load demand of Selected Village.....	27
3.4.	DESIGN OF SOLAR PV SYSTEM	27
3.4.1.	Sizing of the PV Array.....	27
3.4.1.1.	Sizing of the PV Array.....	27
3.4.1.2.	Charge Controller Sizing.....	28
3.4.1.3.	Load Current calculation (Minimum Controller Output Current)	28
3.5.	DESIGN OF WIND TURBINE	28
3.5.1.	Sizing of wind turbine Generator	28
3.5.2.	Wind Charge Controller Sizing	29
3.6.	Hybrid System Batteries Sizing	29
3.7.	Hybrid System Inverter Sizing	30
3.8.	CABLE SIZING.....	30
3.8.2.	Size of the Cable between Charge Controller and Battery	30

3.8.3.	Size of the Cable between the Battery Bank and the Inverter	31
3.8.4.	Size of the Cable between the Inverter and Load	31
3.9.	COST ESTIMATION OF SOLAR - WIND HYBRID SYSTEM.....	33
3.10.	PAYBACK PERIOD	34
CHAPTER 4: FINDING AND DISCUSSIONS		34
4.1.	MODELING AND OPTIMIZATION	34
4.2.	HYBRID ENERGY SYSTEM CONFIGURATION	34
4.2.1.	Wind System.....	34
4.2.2.	SOLAR PV SYSTEM	37
4.2.2.1.	MAXIMUM POWER POINT TRACKING (MPPT).....	39
4.3.	Hybrid System.....	41
CHAPTER 5: CONCLUSION AND RECOMMENDATIONS		43
5.1.	Conclusion	43
5.2.	Recommendations	43
REFERENCES.....		44
APPENDIX: SOME SYSTEM ITEM SPECIFICATIONS.....		47
A.	Solar Pv Specifications.....	47
B.	Wind Turbine specifications	48
C.	Charge Controller Specification	49
D.	Inverter Specifications.....	50

ABBREVIATIONS

ACE: African Center of Excellence
ESD: Energy for Sustainable Development
MPPT: Maximum Power Point Tracking
RESs: Renewable Energy Sources
HPS: Hybrid power system
DC: Direct Current
AC: Alternating Current
HWSPS: Hybrid Wind-Solar Power Systems
HOMER: Hybrid Optimization Model for Electric Renewables
NPC: Net Present Cost
LCOE: Levelized Cost of Energy
O & M: Operation and Maintenance
CSP: Concentrated Solar Panels
NOCT: Normal Operating Cell Temperature
VMPP: maximum power point voltage
IMPP: maximum power point Current
G: solar irradiance [W/m²]
GNOCT: Irradiance at Normal Operating Cell Temperature
T_c: Cell temperature
T_a: Ambient temperature
C_p: Power Coefficient
 ρ : Air density
A: Area
 P_{el} : Electrical power
 P_m : Mechanical power
 η_m : Mechanical efficiencies
 η_g : Generator efficiencies
D: Diameter
HAWTs: Horizontal Axis Wind Turbines
VAWTs: vertical-axis wind turbines
ECSs: Energy Conversion System
E_L: Total Energy Demand

η_B : Battery Efficiency
DOD: Maximum Depth of Discharge
 V_B : Nominal Battery Voltage
 S_D : Days of Autonomy
 T_{cf} : Temperature correction factor
 C_B : Battery Capacity
PWM: Pulse Width Modulation
PV: Photovoltaic
RE: Renewable Energy
REG: Rwanda Energy Group
LED: Light Emitting Diode
TV: Television
 V_{OC} : open-circuit voltage
 I_{SC} : short-circuit current
K: Boltzmann's constant
 V_d : Voltage drops
L: length of wire
MATLAB: Matrix Laboratory

LIST OF FIGURES

Figure 2.1: Map of Rwanda	4
Figure 2.2: Households that use electricity by province.....	4
Figure 2.3: Earth's energy budget schematic	7
Figure 2.4: Monocrystalline Solar Panels	8
Figure 2.5: Polycrystalline Solar Panels	8
Figure 2.6: Thin-Film Solar Panels.....	9
Figure 2.7: Bifacial solar panels	9
Figure 2.8: P-N junction	11
Figure 2.9: simplified schematic of an equivalent solar cell circuit	11
Figure 2.10: A solar cell source's I-V and P-V curves.....	12
Figure 2.11. Schema and Wind turbine components	13
Figure 2.12. Schema and Wind turbine output power Calculation.....	14
Figure 2.13. Typical wind turbine's characteristic curve	15
Figure 2.14. Swept area of wind turbine blades.....	16
Figure 2.15. Wind turbines with a horizontal axis.....	17
Figure 2.16. Wind Turbine with Vertical Axis	17
Figure 2.17. Solar wind hybrid system block diagram	19
Figure 2.18. Centralized AC-coupled hybrid system.....	20
Figure 2.19. Decentralized AC-coupled hybrid system.....	20
Figure 2.20. DC-coupled hybrid system	21
Figure 4.1. Simulink diagram of wind turbine subsystem	34
Figure 4.2. Power Characteristics of wind turbine	35
Figure 4.3. The AC voltages of wind Turbine	36
Figure 4.4. wind energy system Voltage Output	36
Figure 4.5. Solar PV subsystem Simulation diagram	37
Figure 4.6. Voltage vs. Current characteristics.....	37
Figure 4.7. Power vs Voltage characteristics.....	38
Figure 4.8. Output voltage of PV System before boosting	38
Figure 4.9. Output voltage of PV System after boosting.....	39
Figure 4.10. Maximum Power Point Tracking (MPPT) Using boost Converter	39
Figure 4.11. MPP for 1000 radiation	40
Figure 4.12. MPP for 800 radiation	40

Figure 4.13. MPP for 400 radiation	41
Figure 4.14. Hybrid system Simulation model	41
Figure 4.15. Output voltage for wind (10 m/s) and Solar PV (1000W/m ²).....	42

LIST OF TABLES

Table 2.1. Monthly Average Wind Speed at Bigogwe	23
Table 2.2. Average Monthly Wind Speed at Bicumbi.....	23
Table 2.3. Average Monthly Wind Speed at Rwinkwavu	23
Table 2.4. Monthly Average Wind Speed at Nyamagabe	23
Table 2.5. Monthly Average Wind Speed at Kayonza	24
Table 2.6. Monthly Average solar radiation on horizontal surface in Nyamagabe.	24
Table 3.1. Household Load.....	26
Table 3.2. School Load	26
Table 3.3. Cell Building Load.....	27
Table 3.4. Commercial Load	27
Table 3.5. Total demand of selected Village	27
Table 3.6. Wind Turbine Parameters	29
Table 3.7. Findings from the Proposed Off-Grid Solar Wind System's Sizing	32
Table 4.1. Parameters of Wind turbine	35
Table 4.2. PV Module Parameters	37

ABSTRACT

Rwanda faces increasing electricity demand due to population growth and economic development. However, due to low generation capacity and challenges with power system expansion due to the country's hilly terrain, some remote areas lack access to the national grid. The government aims to increase electricity access to 100% by 2024, with 52% connected to the national grid and 48% using off-grid technologies. One potential solution is to adopt renewable energy, particularly a solar-wind hybrid power system. The goal of this research project is to design and carry out a feasibility study of a hybrid solar-wind system for electrifying Gatwa village in Nyamagabe District, which has been found to have sufficient solar radiation and the strongest wind. The study collects wind and solar data from meteorological stations in various regions of Rwanda. The information collected is as follows: At Nyamagabe District, the maximum wind speed of 7.6 m/s along with the horizontal sun radiation of 7.54kWh/m²/day. This hybrid system was designed based on the estimated load of 378,900 Wh/day. To meet the village's electrical energy needs, 88 PV modules, 2 wind turbines, 25 batteries, 20 solar charge controllers, 14 wind charge controllers, and an inverter will be needed. For installation, the suggested hybrid system needs copper wires with cross-sectional areas of 10 mm², 25 mm², 32 mm², and 70 mm². The system's cost estimation is 298,589.15\$ and take 13.6 years as payback period. Comprehensive simulation results that determine the system's viability are provided, along with a description of the full hybrid system. Matlab/Simulink is used for designing a software simulation model.

Keywords: *Renewable Energy, Wind and Solar Energy, Hybrid Solar-Wind System, Rural Electrification, MATLAB Simulation.*

CHAPTER 1: INTRODUCTION

1.1. Background

Rwanda is a landlocked country in East Africa with a growing economy and increasing energy demands. Due to Rwanda is physically composed of so many hills, building transmission as well as distribution lines and even increasing the country's electrical infrastructure, is expensive in most rural regions. The current percentage of households connected to the National grid is 50.9% and off-grid connection percentage is 23.6% and mostly concentrated in towns [1].

In Rwanda, renewable energy sources are being used such as Hydropower plants, Peat power plant and solar energy to supply electricity to communities. Because renewable energy is free, it cannot run out and is thus environmentally beneficial, giving it advantages in terms of its influence on the environment. May renewable energy resources be the best option since they are situated in the areas where the energy is to be used, requiring less transmission and distribution lines?

1.2. Problem Statement

The problem addressed in this feasibility study and design project is the need for a resilient and sustainable power system in Rwanda. Despite efforts to expand the national grid, there are still significant challenges in providing electricity to all regions, especially rural and remote areas. This lack of access to electricity hampers economic development, education, healthcare, and other essential services. Fortunately, the Rwandan government wants to expand the population's access to energy to 1000% by 2024 where 70% households will be connected to the grid while around 30% will be using off grid solutions, and renewable energy sources are being investigated to help reach this objective [1]. However, feasibility study investigation is required for a proper assessment of a solar-wind power system's viability and possible benefits for Rwanda. This system should be capable of providing a hybrid reliable and cost-effective electricity supply, especially to underserved areas, while decreasing dependency on fossil fuels and minimizing the negative effects on environment.

1.3. Research Objectives

The main goal of this study is to design and conduct a feasibility study of a solar-wind hybrid power system in Rwanda.

The specific objectives are:

- i. To conduct a detailed analysis of solar radiation levels, wind speed, and other relevant meteorological data. Identify suitable locations for solar panels and wind turbines based on resource availability.

- ii. To estimate the energy consumption and design a system for electrifying a typical rural village.
- iii. Evaluate available solar and wind energy technologies suitable for the Rwandan context (Technological Evaluation). Assess the reliability, efficiency, and durability of the selected components for the system. Analyze the cost of the system to meet the demand.

1.4. Justification of the Study

Rwanda, like many developing countries, is experiencing a significant increase in energy demand due to population growth, industrial development, and urbanization. The existing power infrastructure is struggling to keep up with the demand, resulting in a substantial power deficit. The implementation of a hybrid power system offers a promising solution to bridge this gap and satisfy the nation's expanding energy requirements. Rwanda government has target of achieving 100% electricity access by 2024 and renewable energy sources are being explored to meet this target This research, which focuses on the potential of renewable energy, will be extremely significant; improve grid stability, achieve cost efficiency, mitigate environmental impact, enhance energy independence, and promote rural electrification.

The study outcomes will provide critical insights and recommendations for the successful implementation of a sustainable and efficient power system in Rwanda.

1.5. Contributions and Gap Addressing

By implementing a solar-wind hybrid system, this system will contribute to closing the energy gap in Rwanda, providing clean and reliable electricity to areas with limited access.

Due to the highest cost of fuel and potential environmental effects, the diesel generator will not be employed as a backup unit for this study. Replacing diesel generator, which was used in the previous studies as backup unit by MPPT Control, this project will significantly reduce greenhouse gas emissions by contributing to Rwanda's environmental sustainability goals.

The development and operation of this hybrid system will create jobs and stimulate economic growth in the region, contributing to poverty reduction and economic development.

By adopting advanced renewable energy technologies and storage solutions, it will help bridge the technological gap in the country and promote innovation.

This project can drive investments in grid infrastructure and energy storage facilities, improving overall energy reliability and resilience.

This project can serve as a model for future renewable energy policy development and implementation in Rwanda and other African countries.

1.6. Scope of Work

Project Overview:

- a. Conduct a comprehensive feasibility study and design for a solar-wind hybrid power system in Rwanda.
- b. Assess the technical, economic, and environmental viability of implementing a hybrid system.

Site Assessment:

- a. Identify potential sites in Rwanda suitable for the installation of a solar-wind hybrid power system.
- b. Evaluate solar radiation and wind speed data to determine the energy potential at selected village.
- c. Conduct on-site visits and surveys to assess the topography, environmental factors, and accessibility of the selected village.

Energy Demand Analysis:

- a. Identify the load requirements and consumption patterns of the intended beneficiaries.
- b. Determine the peak and average power demands to size the hybrid system accordingly.

Technical Design:

- a. Selecting appropriate PV modules, wind turbines, and other necessary components the hybrid system needs.

Economic Analysis:

- a. Conduct a cost analysis, including the capital costs of equipment, installation, and infrastructure.
- b. Assess the operational and maintenance costs over the system's expected lifespan.
- c. Estimate the payback period.

Environmental Impact Assessment:

- a. Evaluate the environmental benefits of the hybrid system, including reduced greenhouse gas emissions and air pollution.

1.7. Literature Review

For understanding which renewable resources to be exploited in Rwanda for rural electrification goals and challenges based on load estimation in a certain area, I will use to consult books, review other theses, class notes, search on the internet, and seek related documentations to the topic of present research.

CHAPTER 2: LITERATURE REVIEW

2.1. Country Overview: Rwanda

Rwanda is a landlocked country in East Africa that is 26,338 km² in area and has 13,246,394 people [2]. It is bordered by Burundi to the south, Tanzania to the east, Uganda to the north and the Democratic Republic of the Congo to the west. Despite being a small country, Rwanda has made significant progress in its economic development and sustainable energy initiatives.

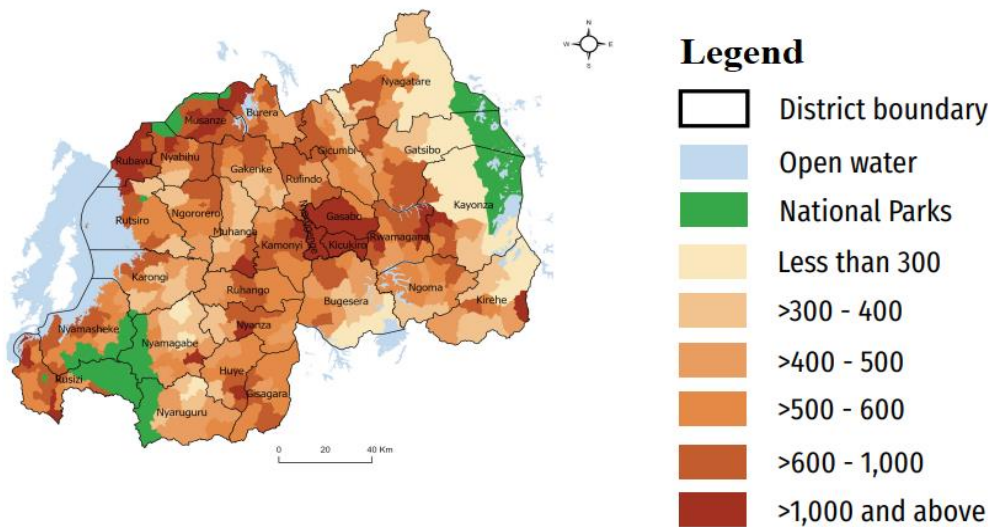

Figure2.1: Map of Rwanda

Source: National institute of statistics of Rwanda. Annual report [2]

2.1.1. Households that use electricity as the main source of lighting

The following map shows households that use of electricity by each Rwanda’s province

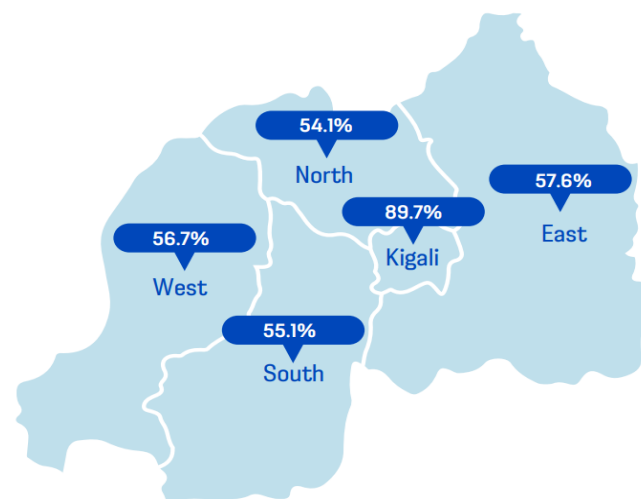

Figure 2.2: Households that use electricity by province

Source: National institute of statistics of Rwanda. Annual report [2]

2.2. Review of Related Works

The feasibility study and design of a solar-wind hybrid power system in Rwanda is an important topic that aims to address the country's energy needs, promote renewable energy sources, and reduce dependence on fossil fuels. In this review, we will explore the related work conducted in this area to gain insights into the feasibility, design considerations, and potential benefits of such a hybrid system in Rwanda.

According to Aqsa Naeem, Naveed U1 Hassan and Naveed Arshad [3] Design of Solar-Wind Hybrid Power System by using Solar-Wind Complementarity. This research included an investigation of the wind- solar energy system and complementarity potentials in order to determine the best locations and starting values for the RES mix. This research looks at the feasibility of implementing a hybrid power system (HPS) based on renewable energy sources (RESs) to generate electricity. It was suggested to utilize the complementarity between Wind and Solar energy to stabilize the combined output power in a hybrid system by using a generic planning framework for implementing these two sources of energy. It has been shown that HPS power outputs fluctuate less than the outputs generated by standalone solar or wind energy-based power systems.

A research carried out by Berino Francisco, Silinto Nelso and Alberto Bila [4] Feasibility Study of Solar-Wind Hybrid Power System for Rural Electrification at the Estatuene Locality in Mozambique. To discover the best strategy for electrifying Estatuene using both renewable energy sources (solar and wind) the feasibility analysis was conducted using the HOMER software. For 12 meters above the ground, the mean wind speed is 4.84 m/s, and the annual mean solar potential is 5.205 kWh/m²/d.

A feasibility study was conducted by Fadi Al-Turjmana , Zakria Qadir ; Mohammad Abujubbehb, and Canras Batun [5] for Feasibility analysis of solar photovoltaic-wind hybrid energy system for household applications.

The aim of this study is to analyze the techno-economics of a hybrid PV-wind system to supply Guzelyurt, Northern Cyprus, with enough electricity for the typical household.

The results demonstrated that the system was economically feasible Because the energy cost given by the system was less than the current price of electricity supplied by the national grid, Thesis done Rashid Al-Abri, Mohammed Albadi, Amer Al-Hinai, and Abdullah Al-Shereiqi [6] Optimal Sizing of Hybrid Wind-Solar Power Systems For the purpose of reducing output fluctuations.

According to the availability of renewable energy resources, the goal of the research is to continuously provide the highest grid output power while scaling the HWSPS to reduce the effects of unreliable renewable energy. For selecting the optimal wind farm at the beginning, a genetic algorithm is employed. Based on the reference wind power, a numerical iterative procedure was used in the second stage.

Investigation of Renewable Energy Potential for Rural Electrification in Rwanda: Technical and Economic Viability' by Cyrus Wekesa Wabuge, Maurice K. Mang'oli, and NISINGIZWE [7]. This study uses a technical and economic analysis to examine the possible role of renewable energy in Rwandan rural electrification, with a special focus on solar-wind hybrid power systems. The solar panel, wind turbine, batteries, and inverter system operate as this hybrid system's main power sources. The backup power source was the diesel generator. The analysis and optimization program utilized was HOMER.

The obtained results show that a \$ 268,000 initial capital investment was needed for this project. The overall O&M cost for the entire system was \$21,376 and the NPC required for this project was \$850,480.

Regarding to the all above studies, in light of the environmental effect and high cost of fuel, the diesel generator will not be employed as a backup unit.

Replacing diesel generator, which was used in the previous studies as backup unit by MPPT Control, this project will significantly reduce greenhouse gas emissions by contributing to Rwanda's environmental sustainability goals

2.3. SOLAR PHOTOVOLTAIC SYSTEM.

The energy derived from the sun in the form of solar radiation is known as solar energy. Photovoltaic and heat engine technology is used to generate electricity using solar energy. Additional applications of solar energy include space heating and cooling via solar architecture, solar hot water, solar cooking, and high temperature process heat for industry [8].

Based on how they absorb, transform, and disperse solar energy, solar technologies are divided into two categories: passive and active.

Photovoltaic panels and solar thermal collectors are two active solar technology used for energy harvesting. Passive solar techniques transform sunlight into heat that may be used in buildings and provide ventilation to heat and cool living areas through air movement.

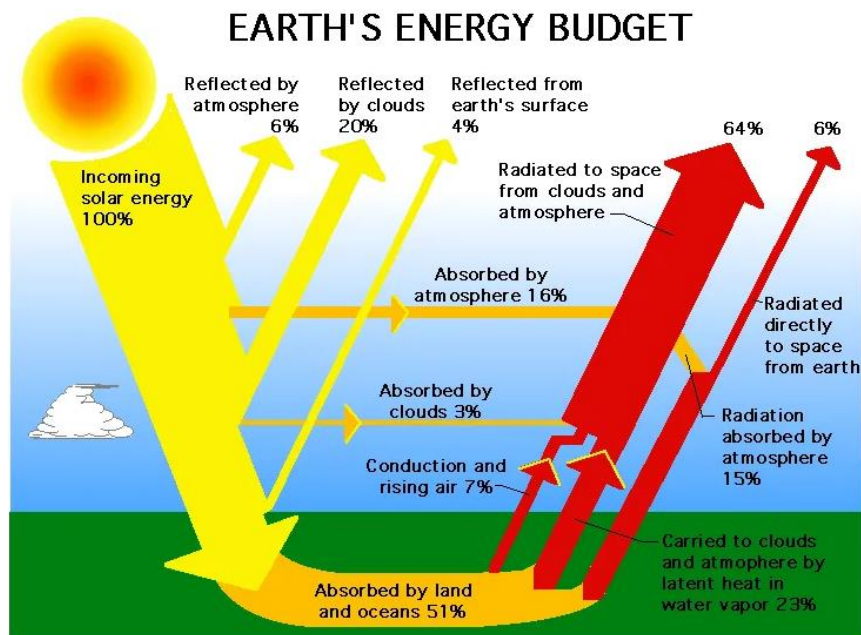

Figure 2.3: Earth's energy budget schematic [9]

Visible light is the main way that the Sun's energy reaches Earth. Eventually, the earth receives more than half of this incoming solar energy. The remaining energy either absorbs by the atmosphere or is reflected away by ice or thick and white clouds. [9].

2.3.1. SOLAR PANELS

2.3.2. Introduction

Solar panels are devices that generate electricity from solar radiation. They are a key component of solar energy systems and have become a very popular renewable energy source in recent years.

Solar panels collect the energy from the sun by utilizing the photovoltaic effect, which is the potential of some materials to produce an electric current when exposed to light [8].

2.3.3. Solar Panels Works Working Principle

The most common type of PV panel consists of interconnected PV cells, typically constructed from silicon. These solar cells consist of multiple layers of semiconductor materials that generate an electric field when exposed to sunlight [10] [11]. When light photons (particles) hit the surface of solar cells, they transmit that energy to the material, which causes the electrons to flow and produce an electric current. Solar panels are generally linked in an array or bigger system to improve performance. To produce greater voltages or currents, a panel can be joined to others in a series or parallel configuration. This allows for the production of electricity suitable for various applications, from powering small electronic devices to supplying electricity to homes, businesses, and even entire power grids [11] [8]

2.3.4. Types of PV Panels

There are different types of PV panels available on the market, each with unique benefits and traits. When selecting the best kind of solar panel for a certain application, it is vital to take into account aspects including efficiency, cost, available space, and special project needs [8].

Here are some common types:

2.3.4.1. Monocrystalline Solar Panels

A monocrystalline solar panel is PV module composed of monocrystalline solar cells. The product's name is derived from the cylindrical silicon ingot that was used in the panel, which was produced from ultra - pure single crystal silicon. More effectively electrical flow is produced by the single crystal structure of the cell, which allows the electrons more space to move. They are known for their high efficiency and space-efficient design, making them ideal for installations with limited roof space [12].



Figure 2.4: Monocrystalline Solar Panels

2.3.4.2. Polycrystalline Solar Panels

They are composed of many silicon crystals, resulting in a speckled blue color. They are less expensive to manufacture compared to monocrystalline panels but generally have slightly lower efficiency.

They are suitable for installations with ample roof space [13] [8].



Figure 2.5: Polycrystalline Solar Panels

2.3.4.3. Thin-Film Solar Panels

They are made by depositing a thin layer of semiconductor material onto a substrate. Most of them are flexible and lightweight, which allows for diverse applications such as solar shingles, solar windows, and curved surfaces. Although thin-film panels are generally less efficient, they can function better in low-light conditions [13] [8].

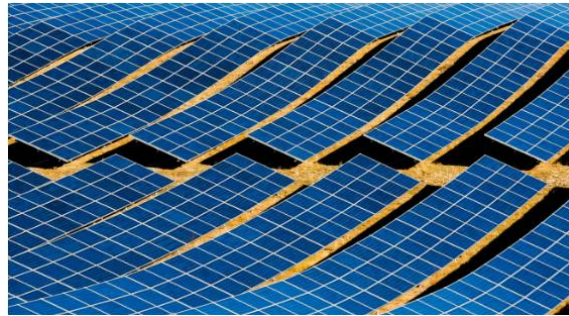

Figure 2.6: Thin-Film Solar Panels

2.3.4.4. Bifacial Solar Panels

These Panels have the ability of generating electricity from both sides of the module. They have a transparent back sheet or glass on the back side, enabling the reflection of sunlight from the ground or other surfaces. Bifacial panels can enhance energy production, especially in locations with reflective surfaces like snow or white roofs [13].



Figure 2.7: Bifacial solar panels

2.3.4.5. Concentrated Solar Panels (CSP)

Lenses or mirrors are used in CSP systems for concentrating sunlight onto a small space, typically focusing on a receiver that contains a heat transfer fluid. The heated fluid then produces steam, which drives a turbine to generate electricity. CSP is mainly used in large-scale solar power plants and has the benefit of being able to store thermal energy for power generation when the sun is not shining [8] [4].

2.3.5. Solar Cell

A solar cell is an electrical device that uses the PV effect to directly transform light energy into electricity. A device whose electrical characteristics, such as current, voltage, or resistance, change in reaction to light is known as a photoelectric cell. The modules, also known as solar panels, are made up of individual solar cell units [14] [4].

2.3.6. Silicon Cells Working Principal

The SC represents the intersection of two distinct semiconductor material types, namely the n and p types. When they are combined, the p-type material's free holes migrate to the n-type material, similar to the way electric charges move, whereas the n-type material's free electrons migrate to the p-type material, producing the so-called diffusion current [4] [15].

Both donor and acceptor ions are left behind on the prior substance as the charge carriers (holes and electrons) move from one side to the other. These left ions produce spatial charges, and as a result, the equation that follows describes the electric potential [4].

$$V = \frac{KT}{q} \ln \frac{n_n}{np} \quad (2.1)$$

Where:

n_n is electron concentration, np is hole concentration, K is $1.38 \times 10^{-23} JK$ (Boltzmann constant), q is $1.6 \times 10^{-19} C$ (electric charge), and T is temperature in [$^{\circ} K$]. The electric field is shown in the following expression [16].

$$E = \frac{KT}{q} \frac{1}{n} \nabla n \quad (2.2)$$

E: Electric field

The drift current (also known as the "diffusion force") flows in the opposing way of the diffusion force as a result of the electric field generated by spatial charges present on a p-n junction.

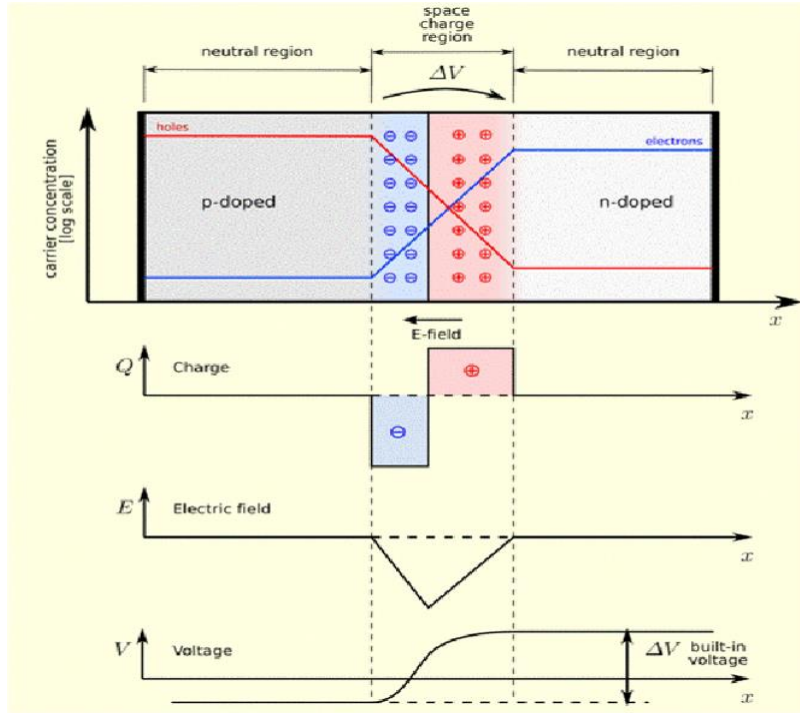

Figure 2.8: P-N junction [17]

2.3.7. Equivalent solar cell circuit

Figure 2.9 below shows a simplified schematic of the equivalent of an ideal SC., where voltage and current loss are not taken into consideration.

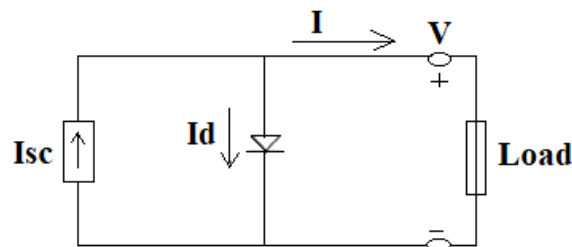

Figure 2.9: simplified schematic of an equivalent solar cell circuit

Kirchhoff's law is applied to calculate the short circuit current through the figure above.

$$I_{sc} = I + I_o \left(e^{\left(\frac{qV_d}{mKT} \right)} - 1 \right) \quad (2.3)$$

Where: I_o is the reverse saturation current of the diode; V_d is the junction voltage; m is the ideality factor of diode. The diode Current (I_d) is calculated as follows:

$$I_d = I_o \left(e^{\left(\frac{qV_d}{mKT} \right)} - 1 \right) \quad (2.3)$$

The expression (2.3) may be used to determine two operating points of the solar cell, as follows:

For short circuit: ($V_d = 0$ leading to $I_d = 0$), thus: $I_{sc} = I$ (2.4)

For open circuit: ($V_d = V_{oc}$, $I = 0$)

From equation (2.3), we get the open circuit voltage V_{oc} :

$$V_{oc} = \frac{mKT}{q} \ln\left(\frac{I_{sc}}{I_0} + 1\right) \quad (2.5)$$

The two parameters that the manufacturer provides, open circuit voltage (V_{oc}) and short circuit current (I_{sc}), are crucial for drawing the I-V curve (Figure 2.10), that is used to predicting the SCs' capacity of operating at different temperatures, voltage loads, and insolation levels. The equation provides the power produced by the cell is $P = IV$.

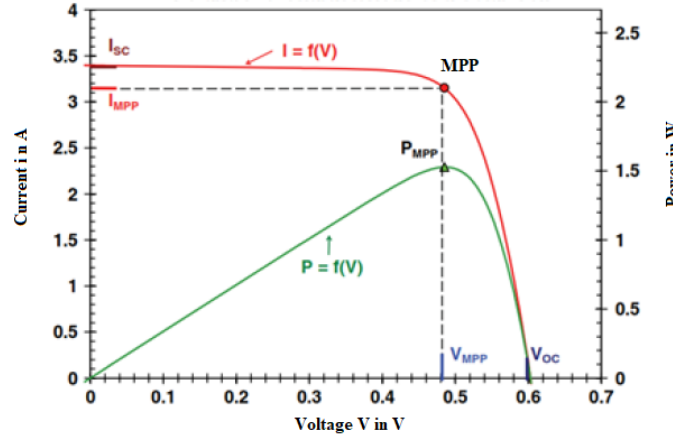

Figure 2.10: A solar cell source's I-V and P-V curves [18] [19]

On this curve, the most significant point is the MPP (maximum power point), or the point at which maximum power output from the module occurs. The outputs of module [voltage and current at maximum power point (V_{MPP} & I_{MPP})] are always located where the curve starts to bend [4] [19].

The Fill Factor (FF) is an additional parameter that indicates the degree of deviation of the I-V curve. The maximum power that can be achieved divided by the product of the open-circuit voltage and short-circuit current is known as the fill factor, and is given by:

$$FF = \frac{I_{MPP} \cdot V_{MPP}}{I_{SC} \cdot V_{OC}} \quad (2.6)$$

The power density provided at the operational point as a percentage of the incident light power density P_s is the conversion efficiency (η) of SC which may be obtained using the following formula:

$$\eta = \frac{FF_{MPP} \cdot V_{MPP}}{P_s} \quad (2.7)$$

2.4. WIND ENERGY RESOURCE

Although Rwanda's potential wind power in some regions may supply energy with potential applications including water pumping, and electricity generation, it is currently not totally exploited for power generation.

The findings of a study conducted across the country on wind speed distribution are as follows:

- ❖ The wind's direction change from 40° to 130°
- ❖ The wind speed change from 2m/s to 9.5 m/s

Rwanda's synoptic stations and data summaries are managed by the National Meteorological Service

2.4.1. Working of Wind Power System

wind energy is another renewable energy source that may be used to produce electrical energy with the help of generators and wind turbines. Wind power systems convert the kinetic energy of circulating air, or the energy in the wind, into a different type of useful power, usually mechanical or electrical. Wind turbines are the devices wherein this conversion takes place. When an air current moves through the area swept by a wind turbine's rotor, energy is transformed. [11] [20]

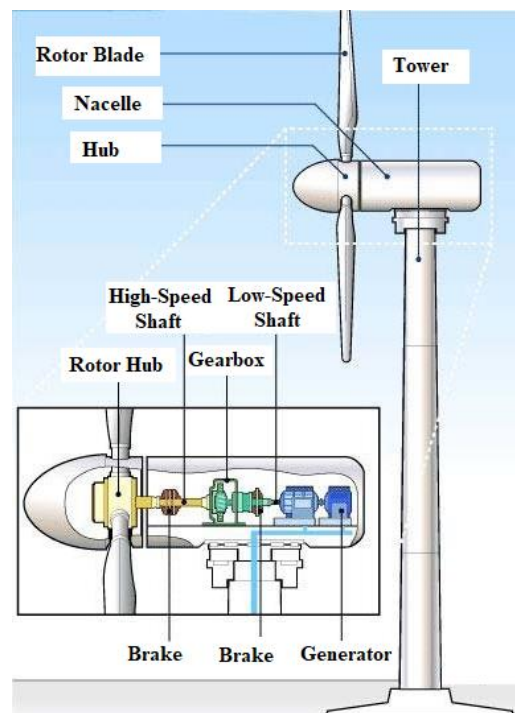

Figure 2.11. Schema and Wind turbine components [21]

The velocity of the wind, which varies significantly with place and time, determines how much energy it contains. As a result, not every locations are appropriate for installing wind energy. Kinetic energy in the wind increases with wind speed. When flowing through a wind turbine, kinetic energy cannot be all converted into other forms of energy. The term power coefficient (C_p) stands for to the ratio of the kinetic energy available in the wind to the kinetic energy that can be transformed in wind turbines. The energy that a wind stream is capable of transferring to the turbine is represented by this parameter.

By taking into consideration the fluid mechanics of the flow through a power-generating rotor, as well as the aerodynamics and rotor performance /generator combination, the actual power generation capability of a wind turbine must be determined.

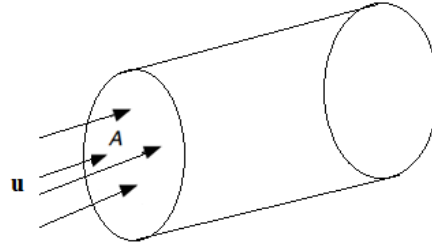

Figure 2.12. Schema and Wind turbine output power Calculation

The following equation shows how a wind turbine's power output varies with wind speed.

$$P_{out} = \frac{1}{2} * C_p * \rho * A * V^3 \quad (2.9)$$

Where:

P_{out} is output power, C_p is power coefficient, ρ is air density, A is swept area by the rotor blades and V is wind velocity. [22].

Betz' limit or law: The possible maximum power can be extracted from the wind energy. It is 59.3% of available power in the wind.

The power produced by the electrical generator is less than the power extracted by the turbine blades because of mechanical, transmission, and generator losses. Mechanical power available for the load machine is obtained as follow:

$$P_m = \frac{1}{2} \rho A V^3 C_p \eta_m \quad (2.10)$$

The expression for the electrical power of a wind turbine is:

$$P_{el} = \frac{1}{2} \rho A V^3 C_p \eta_m \eta_g \quad (2.11)$$

P_{el} : Electrical power [Kw]; P_m : Mechanical power [Kw]; η_m : Gear box efficiencies [%] and η_g : Generator efficiencies [%]

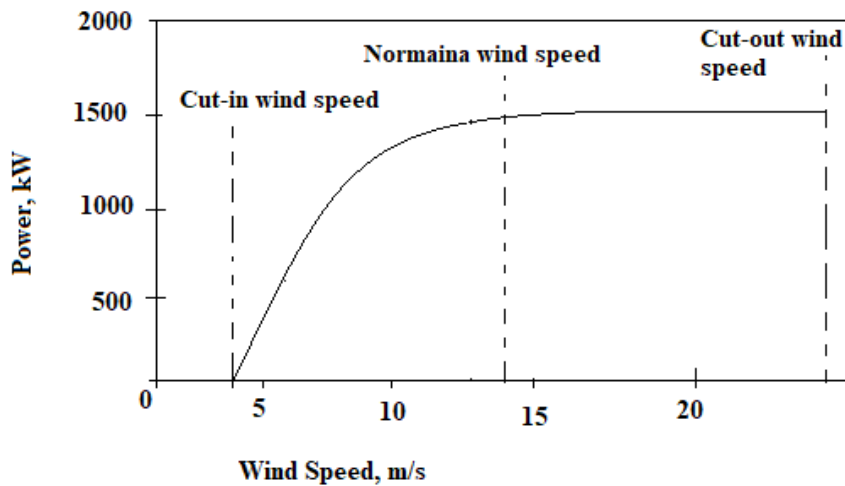

Figure 2.13. Typical wind turbine's characteristic curve [23]

The wind turbine's characteristic curve, which shows how power output varies with wind speed, is illustrated in the above figure. However, given the characteristics curve of any wind turbine, particular attention should be paid to the following three parameters:

- ❖ **Cut-in Wind speed:** Is the speed at which the turbine initially rotate and generate power and is normally between 3 and 5 m/s but can vary based on the design of the turbine.
- ❖ **Cut-Out Wind speed or (Cut-off Wind speed):** it is the peak wind speed at which turbine must be shut down in order to prevent damage to the equipment. For the majority of wind turbine, the cut off speed is 25m/s [24] [25].
- ❖ **Nominal Wind Speed:** is the lowest wind speed that allows the turbine to run as efficiently as possible. This is equivalent to the generator's rated electrical power output, that it is capable of handling. The estimated speed is normally around 15 m/s [24] [26].

Other important parameters to take into account in this situation are the following: the survival wind speed and the rotor swept area:

- ✓ **Survival wind speed:** This is the greatest wind speed that a particular wind turbine can withstand before it is unable to continue operating above the cutout wind speed. The survival speed is in the range of 50 m/s to 60 m/s [24].
- ✓ **Rotor swept area:** The size of the swept area by the turbine blades is known as the rotor swept area. More power can be collected due to increased rotor sweep areas and turbine blade sizes [27]. The Power Coefficient is an indicator about how effective the turbine is at extracting power from the wind.

That area is expressed as follow:

$$A = \frac{\pi D^2}{4} \quad (2.12)$$

A: Area [m²]

D: Diameter [m]

Air density: More energy harnessed by the turbine by more heavy air. Mass per volume is an expression of density, whereas the two airflow parameters determine the value of kinetic energy. The local variations in air pressure and temperature have an impact on this as well.

$$\rho = \frac{P}{RT} \quad (2.13)$$

ρ : Air Density [kg/m³], P: Air pressure [Pa], R: Gas constant [287 J/kg^ok] and T: Absolute temperature of air [°k]

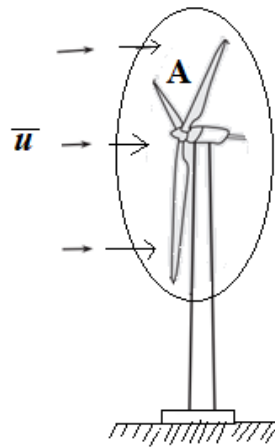

Figure 2.14. Swept area of wind turbine blades [28] .

2.4.2. Wind Turbine

A wind turbine is a fan with three blades that rotate due to wind flow, and the direction of the wind flow must be aligned with its axis of rotation. A gear box, is a mechanical device that is used to transfer energy from one device to another. Although there are many different forms of wind turbines, the two most commonly used types are horizontal axis and vertical axis wind turbines. [10].

2.4.2.1. Horizontal Axis Wind Turbines (HAWTs)

The shaft electrical generator and rotor of these wind turbines are located at the top of a tower and must be directed into the wind; contain the main rotor shaft and electrical generator at the top of a tower. The rotor blades' axis of rotation is parallel to the wind's direction. The horizontal hub is connected to a gearbox and generator, which are located inside the nacelle [29] [30]. A simple wind vane points small turbines, whereas wind sensors and yaw systems are often used to point big turbines.

Most contain a gearbox, which converts the blades' sluggish spin into a faster rotation more suited for powering an electrical generator. The majority of horizontal axis turbines have their rotors upwind of the supporting tower. These are available either in two-bladed or three-bladed and operate at high speed.

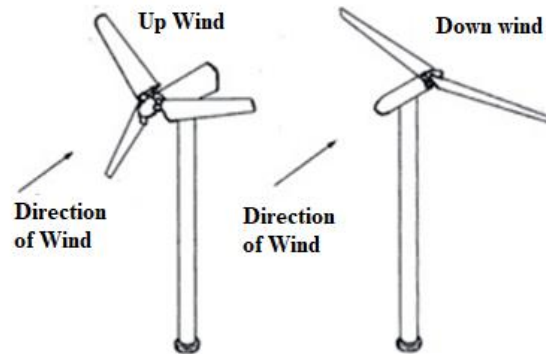

Figure 2.15. Wind turbines with a horizontal axis [31] [32]

2.4.2.2. Vertical Axis Wind Turbines

The main rotor shaft of vertical-axis wind turbines (or VAWTs) is positioned vertically. The turbine does not need to be pointed into the wind to be effective with this setup, which is a benefit at a location where the wind direction is frequently varied. On the main shaft, the rotor blades are mounted in a vertical hub. The rotational axis of the rotor blades is perpendicular to the wind direction. [29] [30].



Figure 2.16. Wind Turbine with Vertical Axis [33]

2.5. Identified solutions for remote area electrification

To prevent an electrical project in a rural area from failing, several of decisions and criteria need to be taken into consideration while selecting technologies for the purpose of electrification.

The first stage in electrifying a region is to identify the most suitable technology based on available potential energy and a pre-feasibility investigation conducted in the area taking into account any existing or potential local grid problems. Information about potential clients and their anticipated load, project consumer demand, and productive possibility should all be taken into account when choosing the technology, the different sectors' capacity and willingness to pay, their demands for supply reliability, details about their distance from the current grid, and the accessibility of local energy resources.

2.5.1. Isolated Grid Solution

The local resources that are available will determine the production technology. Remember that grid network is not linked to an isolated grid.

2.6. PV-Wind Hybrid Power System

Two different energy sources are combined in a hybrid energy system to provide electricity to the load. In other words, it may be said that "A hybrid energy system is one that is created or designed to extract power by utilizing two energy sources.

For regions where grid extension requires significant financial investment and for physically remote locations where power transmission from centralized utilities is challenging, like in the case of Rwanda, it is an acceptable way of providing electricity from locally accessible energy sources. The use of hybrid energy systems is reliable, efficient, economical and efficient. In the suggested system, power is produced using solar and wind energy. Compared to other non-conventional energy sources, solar and wind have a number of benefits. Both energy sources are more widely available everywhere. It requires less money. To deploy this system, no specific site is required.

As our case study illustrates, the solar panels and wind turbine are utilized to generate power in a solar wind hybrid system with limited solar and wind resources. The block design of this system is displayed in figure 2.17.

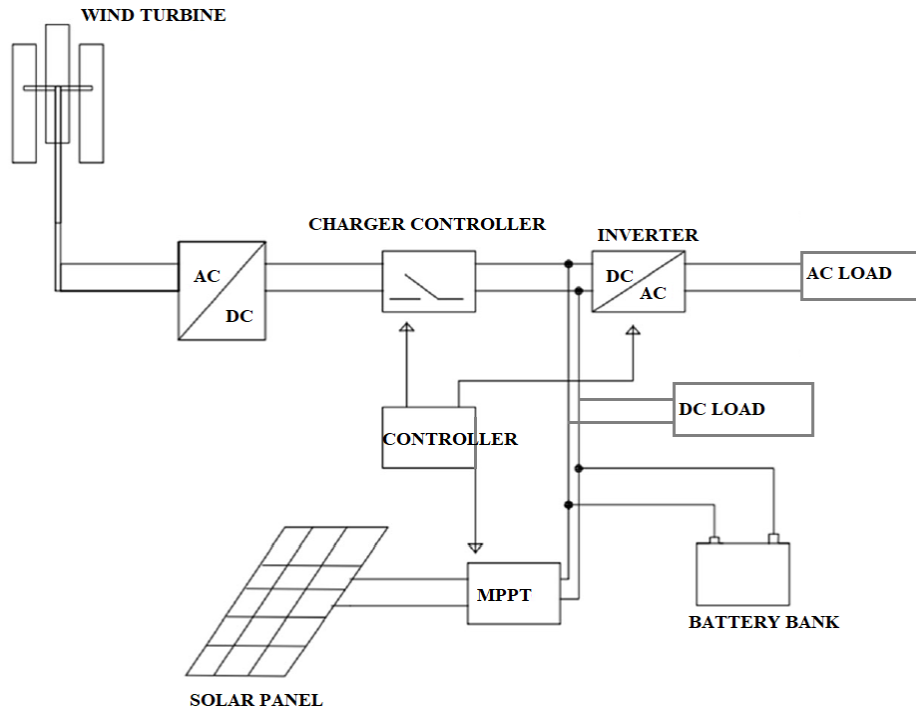

Figure 2.17. Solar wind hybrid system block diagram [34]

2.6.1. Technical configurations for hybrid power systems

The hybrid system can be designed in different configurations and effectively utilize the existing renewable energy sources in the area and to supply electricity to all electrical appliances; Hybrid systems can be classified as follows [35].

- ❖ AC-coupled, DC-coupled, and mixed-coupled and Mixed-coupled hybrid power systems

2.6.1.1. AC-coupled Hybrid Power Systems

In this configuration. The several hybrid power systems (HPSs) and the load are connected together to the AC-bus.

Centralized AC-coupled HPSs and Distributed AC-coupled HPSs are the two sub-topologies that comprise the AC linked HPSs.

2.6.1.1.1. Centralized AC-coupled Hybrid Power Systems

An AC-coupled HPS is said to be centralized when the energy conversion systems are connected to a main AC-bus before being connected to the load.

Wind turbines can be directly connected to the main AC-bus or through an AC/AC converter as it generates AC power. As PV-array generates DC power, before connecting the PV array to the main AC bus an inverter is required.

A bidirectional inverter is required to control the energy supplied by the battery bank when charging or discharging it using a DC current. [35].

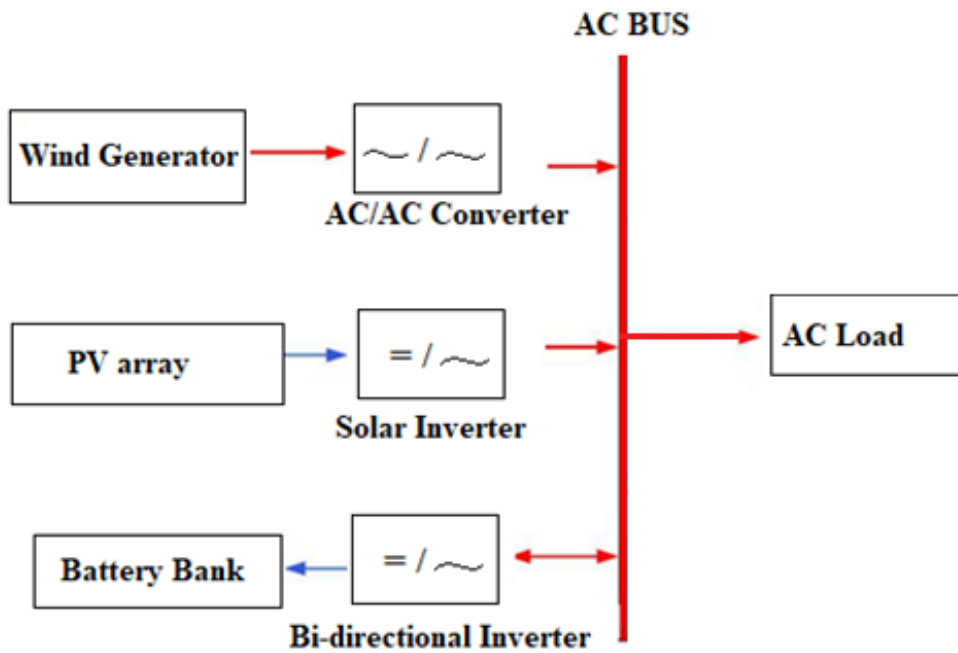

Figure 2.18. Centralized AC-coupled hybrid system

2.6.1.1.2. Distributed AC-coupled Hybrid Power Systems

AC-coupled HPSs is said to be distributed or decentralized when the Energy Conversion System (ECSs) that make up it are not all individually coupled to the load; otherwise, some or all of them are coupled to the load [35].

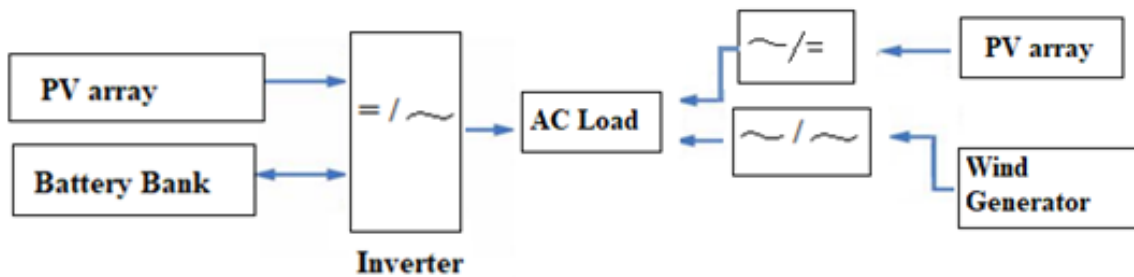

Figure 2.19. Decentralized AC-coupled hybrid system

As opposed to the leading up configuration, this one does not require that the power sources be coupled to one common bus. Each source is connected to the load independently, and these sources may not be installed close to one another. Before supplying the AC load, the DC power from the PV system and battery must be converted to AC, hence the proper inverters are needed [35]. When comparing centralized and decentralized HPSs, centralized HPSs are preferable than decentralized HPSs in terms of performance and ease of management.

2.6.1.2. DC-coupled Hybrid Power Systems

Systems Energy Conversion in a DC-coupled HPS system are coupled to a DC main bus before being connected to the load. A main inverter is used to connect to the AC loads. This arrangement is known as a centralized DC-bus topology.

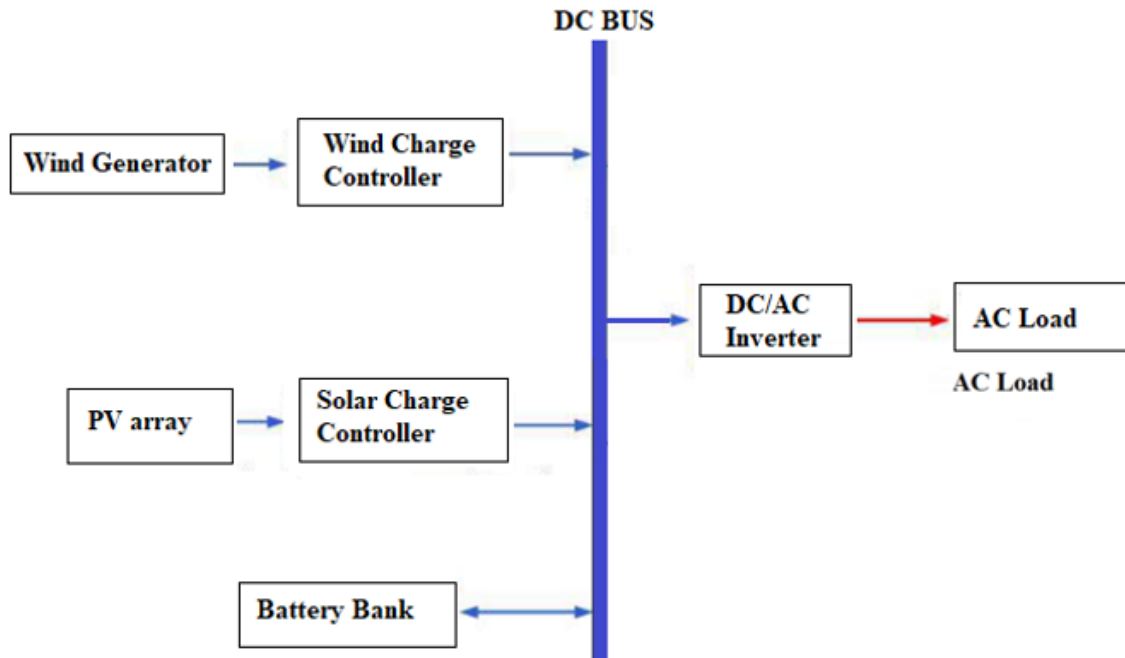

Figure 2.20. DC-coupled hybrid system

The wind turbine requires an AC-DC converter before it can be connected to the main bus since the energy sources are connected at the DC-bus bus.

2.6.2. Storage Battery

A battery energy storage system makes it simple to collect energy and store it for later use, such as a backup for peak demand or to power off-grid applications. Two major battery types used in hybrid systems are Nickel-cadmium and lead-acid batteries. Due to its low energy efficiency, highest cost as well as limited maximum operating temperature, nickel-cadmium batteries are only used in few systems. Therefore, in hybrid systems, lead-acid batteries are mostly used as energy storage to store excess energy, control system voltage, and provide load in the case of insufficient solar or wind energy due to its highly efficient technology and maintenance-free. [36] [37]. There are several capacities of the nominal voltage available, including terminal voltages of 2 V, 6 V, 1 V, and 24 V.

The depth of discharge, which measures how much of a battery's energy storage capacity is used at once, has an impact on its lifespan.

When there is inadequate solar radiation or wind blow, the energy produced by renewable energy conversion technologies experiences energy outages. To prevent such shortages, a battery bank should be able to sustain days or hours of self-sufficiency [38].

The battery capacity needed to meet the entire load demand can be calculated with the help of the following elements:

- ❖ E_L : Total Energy Demand [wh]
- ❖ η_B : Battery Efficiency [%]
- ❖ (DOD) max: Maximum Depth of Discharge
- ❖ V_B : Nominal Battery Voltage [V]
- ❖ S_D : Days of Autonomy [days]
- ❖ T_{cf} : Temperature correction factor

Therefore,

$$\text{Battery Capacity } (C_B) = \frac{E_L * S_D}{\eta * DOD * T_{cf} * V_B} \quad 2.14$$

2.6.3. Inverter/ Converters

The PV system needs a solar inverter to convert the generated DC voltage into the AC voltage needed by various AC loads. Inverter converts DC to AC power by switching the DC input voltage (or current) in a pre-determined sequence to produce AC voltage (or current) output.

Known as a rectifier, the AC/DC power converter performs the opposite function of an inverter. It changes the AC input voltage into an output voltage of rectified direct current. As component of the hybrid system in this study, AC/DC converter or bi-directional DC/AC type was used.

2.6.4. PV Controllers

The major function of PV charge controller is to prevent the battery from being overcharged by a PV array system by regulating the flow of electricity from the PV Panels to the batteries. Batteries in photovoltaic systems need to be kept in a fully charged condition and protected from overcharging. When the batteries are fully charged, the controller will cut off or stop the current flowing from the PV array into the batteries. For this thesis, an analytical efficiency of 95% has been employed [16]. It is recommended to split the PV array into smaller arrays if more than one controller is being utilized and a significant current is required to supply a specific load. As PV controllers are available in five main varieties: maximum power point, diversion, shunt, single-stage series, and pulse width modulation (PWM) controllers; in this thesis, MPPT is utilized because, in comparison to PWM controllers, it can extract an extra 15–30% more power from an array [16].

2.7. Wind Energy Potential in Rwanda

The Rwandan synoptic stations are under the National Meteorological Service's management, and it also provides data records. The National Meteorological Service supplied measured daily maximum wind speed data

Table 2.1. Monthly Average Wind Speed at Bigogwe (2021)

Months	Jan	Feb	Marc	April	May	June	July	Aug	Sept	Oct	Nov	Dec	Avr
Wind Speeds m/s	6.7	3.89	6.73	7.65	6.37	7.49	6.07	5.9	5.7	5.6	5.9	7.3	6.3

Table 2.2. Average Monthly Wind Speed at Bicumbi (2019;2020)

Months	Jan	Feb	Marc	April	May	June	July	Aug	Sept	Oct	Nov	Dec	Avr
Wind Speeds m/s	7.2	6.8	6.3	6.5	6.1	6.38	6.7	6.79	7.35	7.2	6.5	6.7	6.7

Table 2.3. Average Monthly Wind Speed at Rwinkwavu (2021)

Months	Jan	Feb	Marc	April	May	June	July	Aug	Sept	Oct	Nov	Dec	Avr
Wind Speeds m/s	4.1	5.5	4.6	4.3	4.2	4.2	3.2	4.1	6.7	5.9	5.2	4.3	4.7

Table 2.4. Monthly Average Wind Speed at Nyamagabe (2020)

Months	Jan	Feb	Marc	April	May	June	July	Aug	Sept	Oct	Nov	Dec	Avr
Wind Speeds m/s	8	8.1	7.3	7.7	7.5	5.8	5.7	6.7	8.8	9.5	9.2	7.4	7.6

Table 2.5. Monthly Average Wind Speed at Kayonza (2020)

Months	Jan	Feb	Marc	April	May	June	July	Aug	Sept	Oct	Nov	Dec	Avr
Wind Speeds m/s	3.9	4.6	4.5	4.7	4.6	3.7	5.1	4.1	3.7	2.9	3.1	4.1	4.1

According to the table 2.4, the strongest wind in Rwanda is located in Nyamagabe District, Southern Province, and is distinguished by a greater frequency of wind speed than other regions.

2.8. Solar Energy Potential in Rwanda

The Monthly Average solar radiation data that is shown in the following table 2.6 is the solar data that was entered into the MATRLAB SIMULINK software; the electricity produced by the solar PV is obtained by recording data in units of W/m^2 is very important.

Table 2.6. Monthly Average solar radiation on horizontal surface in Nyamagabe (2019).

Months	Jan	Feb	Marc	April	May	June	July	Aug	Sept	Oct	Nov	Dec	Avr
Solar radiation (kWh/m ² /d)	7.3	7.8	8	8.1	7.9	6.7	6.7	6.9	7.4	8.1	7.7	7.9	7.54

CHAPTER 3: METHODOLOGY

3.1. INTRODUCTION

The primary data commonly referred to as first-hand data, that are acquired as part of the research project include local data collecting as well as visits to various government organizations. The Rwanda Energy Group (REG Ltd) and Meteorology-Rwanda are among the organizations that were visited. Secondary data collection, on the other hand, comprises information that already exists but was not gathered by the researcher. Publications like articles, reports, or literature are common formats for secondary data representation.

The following research methodology was used to meet our goals:

- ❖ Getting the data on solar and wind power from different organizations.

- ❖ Identifying the load profile of the village.
- ❖ Evaluating characteristics of the components to obtain the input parameters required by our software MATLAB for the purpose of simulating and modeling the system for the selected village.

Estimating the daily load profile is essential and requires consideration of the many different factors available in the village. The number of households and utility services, family income and ambition for buying electrical equipment, and possibly small business that could possibly start if power is available were all taken into consideration. Therefore, the above factors contributed in determining the village's required load estimation.

3.2. MODELING SOFTWARE: MATLAB SIMULATION

The main components and technical details of the system have already been explained in the previous chapter. As stated in the problem statement, the main purpose of this study is to conduct a feasibility study of a solar-wind hybrid power system in Rwanda to assess the viability and potential benefits of a hybrid power system for meeting the need for electricity in remote areas where the cost of national grid extension is higher. For this project, combinations of renewable energy sources (wind and Solar) with different component capability must be considered. The simulations are carried out using MATLAB software.

3.3. Gatwa VILLAGE LOAD ESTIMATION

After discovering that the Nyamagabe District has potential for wind and solar energy, estimating the population for the area is the next step to calculate the required electrical load.

The electric load taken into account at this time is intended to meet the needs of 300 households, which together make up a maximum of 1500 people at the chosen site.

In the scenario of a rural village model with 300 households, in addition to the home appliances that require an electric load supply, the following institutions are present: 10 shops, one school that has 18 rooms and Cell office. Since the nation's economic development is a factor in determining the household appliance load, the first step in estimating the load is to determine where the equipment is primarily used in a moderate family. However, the energy system's current design takes into account a model household that, in a hypothetical scenario, would require just the most fundamental equipment.

Estimating an appliance's energy use, we can use the following formula:

- ✓ Daily energy (kWh) = (Wattage*Backup time)/1000
- ✓ Every appliance's annual energy consumption is equivalent to (daily kWh * number of days it was used).

3.3.1. Household Load

It is advised to apply the required power for Fluorescent lamps or LED lighting, radio and TV in a certain home. Considering that people may leave their TV and radio on for long time, the weekends and holidays often see the highest load demands in homes. Radio will be available for 7 hours and television will run for 14 hours.

Table 3.1. Household Load

Appliance	Power Ratings (W)	Quantity	Total Power (W)	Backup Time (hour)	Total Energy (Wh)
Light Bulbs	7	2100	14700	4	58800
Television	85	120	10200	6	61200
Radio	30	160	4800	4	19200
DVD Player	18	120	2160	4	8640
Decoder	10	50	500	4	2000
Speakers	5	30	150	2	300
Refrigerator	200	20	4000	8	32000
Fluorescent lamps	30	24	7200	3	21600
Cloves Irons	1500	50	75000	1	75000
Computer CPU	550	15	8250	2	16500
Water supply and Irrigation System	550	14	7700	6	46200
TOTAL			134660		341440

3.3.2. School Load

The selected village has a 12 years' basic education school with four administrative offices, five rooms for the ordinary level and thirteen rooms for the primary school and Laboratory room.

Table 3.2. School Load

Appliance	Power Ratings (W)	Quantity	Total Power (W)	Backup Time (hour)	Total Energy (Wh)
Light Lamps	15	75	1125	2	3375
Computers for offices	100	3	300	4	1200
Printers	45	3	135	1	135
Lab Equipments	500	15	7500	1	7500
TOTAL			9060		12210

3.3.3. Cell Building Load

The electrical appliances of Cell office are lighting lamps, computers and are presented as follow:

Table 3.3. Cell Building Load

Appliance	Power Ratings (W)	Quantity	Total Power (W)	Backup Time (hour)	Total Energy (Wh)
Light Lamps	15	5	75	2	150
Computers	100	3	300	5	1500
Printers	50	1	50	1	50
TOTAL			425		170

3.3.4. Commercial Load

The most common types of electrical appliances used in businesses are listed below:

Table 3.4. Commercial Load

Appliance	Power Ratings (W)	Quantity	Total Power (W)	Backup Time (hour)	Total Energy (Wh)
Light Lamps	15	50	750	6	4500
Computers	100	12	1200	2	2400
Printers	45	4	180	1	180
Milling machines	1800	10	18000	1	18000
TOTAL			20130		25080

3.3.5. Total Load demand of Selected Village

Table 3.5. Total demand of selected Village

	Total Power (W)	Total Energy (Wh)
Household Load	134660	341440
School Load	9060	12210
Cell Building Load	425	170
Commercial Load	20130	25080
TOTAL	164275	378,900

3.4. DESIGN OF SOLAR PV SYSTEM

As the system is Wind/Solar Hybrid Power System, let say solar power system will produce **289,915Wh** and wind turbine system will produce **88,985 Wh**.

3.4.1. Sizing of the PV Array

3.4.1.1. Sizing of the PV Array

Total Instantaneous Power is **125695 W** corresponds to the energy of **289915 Wh**

To ensure system reliability, a system designed for maximum demand

$$E = 289915 \times 1.2 = 347898 \text{ Wh} \quad 3.1$$

Sunshine available in a day (hrs) = 10 hrs/day

$$P = \frac{347898 \text{ Wh}}{10\text{h}} = 3478 \text{ W} \quad 3.2$$

Therefore, Selecting PV Panel are available 400 W,

$$\text{Number of Panels} = \frac{34789.8}{400} = 86.9 = 87 \text{ Panels} \quad 3.3$$

Let consider 88 Panels, so that, $88 \times 400 = 35200\text{W}$

3.4.1.2. Charge Controller Sizing

The charge controller should be 125% (or 25% more than the short circuit current of the solar panel. Short circuit current of PV X 1.25 is the solar charge controller's size in amps.

Let P_{\max} be 400 W, $V_{\max} = 34.3 \text{ V}$, $I_{\max} = 9.70 \text{ A}$, $V_{oc} = 41.8 \text{ V}$ and $I_{sc} = 10.30$ and PV panels will be connected in parallel.

The Nominal rating of charge controller is:

$$I_{sc} \times 1.25 \times \text{No of PV} = 10.3 \times 1.25 \times 88 = 1139.6\text{A} \quad 3.4$$

The available Charge Controller in Market is = 100 A;

Therefore, we need around 15 charge controllers connected in parallel according to 1500A required.

3.4.1.3. Load Current calculation (Minimum Controller Output Current)

Total adjusted power is **125695 W** and System Voltage is 24 V

$$\text{Max. DC load current is} = \frac{125695 \text{ W}}{24 \text{ V}} = 5248.5\text{A say } 5249\text{A} \quad 3.5$$

Thus, the charger controller must have nominal input rating of 100 A and an output rating of 5249 A, or a little bit greater.

3.5. DESIGN OF WIND TURBINE

3.5.1. Sizing of wind turbine Generator

The availability of wind resources and the use of wind energy influence the choice of wind turbine, which influences the size of wind turbine, its dependability, warranty, and how close it is to maintenance, operation, and transportation facilities. When choosing high rated wind turbines for off-grid applications in remote areas, transportation of wind turbine components is the most significant challenge. Higher rated wind turbines have longer blades, which are more difficult to transport in remote places. Therefore, it is suggested that rural electrification use small wind turbines.

In this project, the following wind turbine requirements are preferred:

Table 3.6. Wind Turbine Parameters

Parameters		
Operating data	Rated Power	15kW
	Cut-in Wind Speed	2.5 m/s
	Nominal wind speed	10 m/s
	Cut-out Wind Speed	25 m/s
	Survival Wind Speed	50 m/s
Rotor	Rotor diameter	8.4 m
	Swept Area	55 m ²
Generator	Frequency	50/60Hz
	Type	Asynchronous
Tower	Hub Height	17.6m
	type	Tubular steel
Blade	Number of Blades	3

The above wind turbine will produce the following calculated energy:

With a 25% capacity factor, a 15kW turbine would produce:

$$E = 15000W * 24h * 25\% = \frac{9000Wh}{day} \quad 3.6$$

Therefore, **88,985Wh** /90000Wh = 0.98 Say one Wind Turbine. However, based on the availability of wind sources of selected village and rated wind speed of selected wind turbine, let use 2 wind turbine generators of 15 kw each to produce **88,985Wh** /day

3.5.2. Wind Charge Controller Sizing

To calculate the current capacity, divide wind turbine power (in Watts) by the battery voltage
 $30000W/24V= 1250A$

The available Charge Controller in Market is = 100 A therefore, we need around 14 charge controllers connected in parallel according to 1250 A capacity required

3.6. Hybrid System Batteries Sizing

To ensure system reliability, a system designed for maximum demand is $378900 \times 1.2 =$
454680 Wh.

- ❖ Total Energy Demand =454680 Wh
- ❖ Nominal Battery Voltage = 24 V_{dc}
- ❖ Battery Efficiency = 85% = 0.85
- ❖ Days of Autonomy = 1 day
- ❖ Depth of Discharge = 0.6

Therefore,

$$\text{Battery Capacity (Ah)} = \frac{\text{TOTAL Wh Per Day used by Appliance} \times \text{Days of Autonomy}}{(0.85 \times 0.6 \times \text{Nominal Battery Voltage})}$$

$$\text{Battery Capacity} = \frac{454680 \times 1}{0.85 \times 0.6 \times 24} = 37147.05 \text{ Ah} \quad 3.7$$

Available Battery in Market are 1500Ah with nominal 24 Voltage

$$\text{Therefore, } \frac{37147.05}{1500} = 24.76 \text{ Batteries} \quad 3.8$$

By looking 37147Ah, we will need 25 Batteries connected in parallel of 1500 Ah, 24 V each the total will be 37,500 Ah.

3.7. Hybrid System Inverter Sizing

❖ Assume Inverter efficiency is 90%

$$\text{❖ The actual Size of Invertor is} = \frac{164275 \text{ W}}{0.90} = 182527.77 \text{ W} \quad 3.9$$

Therefore, we are selecting the next available Inverter 200000 W (200kW)

3.8. CABLE SIZING

$$A = \frac{\rho \cdot L \cdot I^2}{Vd} \quad 3.10$$

Where: ρ : resistivity of cable, L : length of the cable (in m), A : cross sectional area of cable in mm^2 , I is rated current of regulator in A and Vd is Voltage drops.

Both AC and DC cables are assumed to have a voltage loss of less than 4%.

3.8.1. Size of the Cable between PV Array/ wind turbine and Charge Controller

$$Vd = \left(\frac{4}{100}\right) \times V \text{ module} = \left(\frac{4}{100}\right) \times 24V = 0.96V \quad 3.11$$

$$A = \frac{\rho \cdot L \cdot I^2}{Vd} \quad 3.12$$

$$\rho = 1.724 \times 10^{-8} \Omega \cdot m \quad 3.13$$

Assuming that the length of the cable is 6m and I_{\max} is 100 A

$$A = \frac{1.724 \times 10^{-8} \times 6 \times 100^2}{0.96} = 25 \text{ mm}^2 \quad 3.14$$

Therefore, any copper cable with a cross sectional area of 25 mm^2 , a current of 100 A, and a resistivity of $1.724 \times 10^{-8} \Omega \cdot m$ will be utilized to connect the PV array/ wind turbine to the charge controller's input.

3.8.2. Size of the Cable between Charge Controller and Battery

Let the length of the cable be 2 m and use the same formula as mentioned at 3.8.1.

I Rated is 100 A

$$A = \frac{1.724 \times 10^{-8} \times 2 \times 100^2}{0.96} = 7.18 = 10 \text{ mm}^2 \quad 3.15$$

This implies that any copper wire with a cross sectional area of 10 mm², a current of 100 A, and a resistivity of 1.724 *10⁻⁸ Ω/m may be applied for connecting the batteries and charge controller.

3.8.3. Size of the Cable between the Battery Bank and the Inverter

At full load, the batteries maximum current I_{max} is given by:

$I_{max} = \text{Inverter watts} / V \text{ system}$ Moreover, Inverter capacity is 200000 watts

System voltage (V system) is 24V

$$I_{max} = 8333.3 \text{ A}$$

Assume that the length of the cable is 2m

$$A = \frac{1.724 * 10^{-8} * 2 * 800 * 2}{0.96} = 57.46 = 70 \text{ mm}^2 \quad 3.16$$

This indicates that the cabling between the battery bank and inverter may utilize any copper wire with a cross sectional area of 70 mm², an 800 A current, and a resistivity of 1.724 * 10⁻⁸ Ω.m.

3.8.4. Size of the Cable between the Inverter and Load

Equation below provides the phase current in the three-phase AC supply from the inverter:

$$I_{phase} = \frac{\text{Inverter output}}{V_{out} * \sqrt{3} * \text{Power Factor}} \quad 3.17$$

Inverter output is 200000W

$$V_{out} = 240V$$

PF = say 0.9

At full load on the phase (line), maximum current from inverter is given by

$$I_{phase} = \frac{200000}{240 * 1.732 * 0.9} = 534.5 \text{ or say } 535 \text{ A} \quad 3.18$$

Let the length of the cable be 15m;

$$A = \frac{1.724 * 10^{-8} * 15 * 535 * 2}{9.6} = 28.8 \cong 32 \text{ mm}^2 \quad 3.19$$

For the cabling between the inverter and load, any copper wire with a cross sectional area of 32 mm², a current of 535 A, and a resistivity of 1.724*10⁻⁸ Ω-m can be utilized.

Table 3.7. Findings from the Proposed Off-Grid Solar Wind System's Sizing

Component	Description of Component	Result
Load Estimation	Estimated Load	454680 kWh/day
PV Array	Capacity of PV array	35.2 kW
	Modules in series	4
	Modules in parallels	22
	Total number of modules	88
Wind Turbine	Capacity of Wind Turbines	30 kW
	Capacity of each Wind Turbine	15 kW
	Total number of wind Turbine Generator	2
Solar Charge Controller	Capacity of Charge Controller	1500 A
	Controllers connected in series	3
	Controllers connected in parallels	5
	Total number of Solar charge controllers	15
Wind Charging Controllers	Capacity of Charge Controller	1250A
	Number of Controllers in series	2
	Number of controllers in parallels	7
	Total number of wind charge controllers	14
Battery Bank	Battery bank capacity	37147.05Ah
	Batteries connected in series	5
	Batteries connected in parallel	5
	Batteries required	25
Inverter	Inverter Capacity	200 kVA
Wire	Between PV modules/Wind Turbine and charge controllers	100A, 25 mm ²
	Between solar charge controllers and battery bank	100A, 10 mm ²
	Between wind charge controllers and battery bank	100A, 10 mm ²
	Between Battery bank and inverter	800 A, 70 mm ²
	Between inverter and the Load	535A, 32 mm ²

3.9. COST ESTIMATION OF SOLAR - WIND HYBRID SYSTEM

$$\begin{aligned} \text{a. Arrays cost} &= \text{Number of PV modules} * \frac{\text{Cost}}{\text{Module}} = 88 * 333.3 \$ \\ &= 29,330.65 \$ \end{aligned} \quad 3.20$$

$$\begin{aligned} \text{b. Batteries Cost} &= \text{Number Batteries} * \frac{\text{Cost}}{\text{Battery}} = 20 * 6,950 \$ \\ &= 139,000 \$ \end{aligned} \quad 3.21$$

$$\text{c. Inverter Cost} = \text{Number of inverters} * \frac{\text{Cost}}{\text{Inverter}} = 1 * 17,500 \$ = 17,500 \$ \quad 3.22$$

$$\begin{aligned} \text{d. Cost of charge controller} &= \text{No of the charge controller} * \frac{\text{Cost}}{\text{chargecontroller}} \\ &= 29 * 300 \$ = 8,700\$ \end{aligned} \quad 3.23$$

$$\begin{aligned} \text{e. Cost of Wind Turbine} &= \text{No of Wind Turbine} * \frac{\text{Cost}}{\text{Wind Turbine}} \\ &= 2 * 2300\$ = 4600 \$ \end{aligned} \quad 3.24$$

$$\text{f. cost of Main Circuit Breaker for Laod Protection 1000A} = 1 * 670\$ = 670 \$ \quad 3.25$$

$$\text{g. cost of Circuit Breaker for Laod Protection 32A} = 1 * 40\$ = 40 \$ \quad 3.26$$

$$\text{h. cost of Circuit Breaker for Laod Protection 16A} = 3 * 10\$ = 30 \$ \quad 3.27$$

$$\text{i. cost of power cable (single core 25mm}^2) = 100 * 50\$ = 5000 \$ \quad 3.28$$

$$\text{j. cost of power cable (single core 10mm}^2) = 100 * 30\$ = 3000 \$ \quad 3.29$$

$$\text{k. cost of power cable (single core 70mm}^2) = 100 * 100\$ = 10,000 \$ \quad 3.30$$

$$\text{l. Infrastructure estimated Cost is} \quad 65,000 \$ \quad 3.31$$

$$\begin{aligned} \text{Toatlcost} &= \text{a} + \text{b} + \text{c} + \text{d} + \text{e} + \text{f} + \text{g} + \text{h} + \text{l} + \text{j} + \text{k} + \text{l} \\ &= 282,870.65 \$ \end{aligned} \quad 3.32$$

$$\begin{aligned} \text{m. Installation cost can be estimated at 5\% of the overall cost} \\ &= 282,870.65 \$ * 5\% = 14,143.5 \$ \end{aligned} \quad 3.33$$

$$\begin{aligned} \text{Maintenance cost may be taken as 0.7 \% of total system cost} \\ &= 284,370.65 \$ * 0.7 \% = 1980.1 \$ \end{aligned} \quad 3.34$$

$$\begin{aligned} \text{Total Cost of the Hybrid System / Initial Investment cost} \\ &= 282,870.65 \$ + 14,143.5 \$ = 297,014.15 \$ \end{aligned} \quad 3.35$$

Total annual Cash inflow calculation

$$\text{Cost /kWh} = 0.17\$$$

$$\text{Total energy consumption} = 378.9\text{kWh/day}$$

$$\text{Annual Cash inflow} = 378.9 * 365 * 0.17\$ = 23,836.8\$ \quad 3.36$$

$$\text{Net annual cash inflow} = 23,836.8 - 1980.1 = 21856.7\$ \quad 3.37$$

3.10. PAYBACK PERIOD

It is the amount of time required to recover investment cost. It is initial investment cost divide by net annual cash inflow

$$\text{Payback Period} = \frac{297,014.15}{21856.7} = 13.6 \text{ Years} \quad 3.38$$

CHAPTER 4: FINDING AND DISCUSSIONS

System modeling and the results of the hybrid system simulations carried out in MATLAB SIMULATION are covered in this chapter.

4.1. MODELING AND OPTIMIZATION

As mentioned in chapter 3, the optimization model design process for selecting the optimal choice for sizing the hybrid system was carried out using MATLAB simulation. In this chapter, the various outcomes are presented and contemplated.

4.2. HYBRID ENERGY SYSTEM CONFIGURATION

A 164275 W Solar –Wind hybrid system is modelled. The specifications for the wind turbine and solar PV system are given in Tables 4.1 and 4.2, respectively. The wind and solar PV subsystems are shown in Figure 4.1 and 4.5, respectively.

The system is first simulated using only solar and wind energy, and the effectiveness of each system is assessed. Thereafter the effectiveness of the hybrid system is assessed.

4.2.1. Wind System

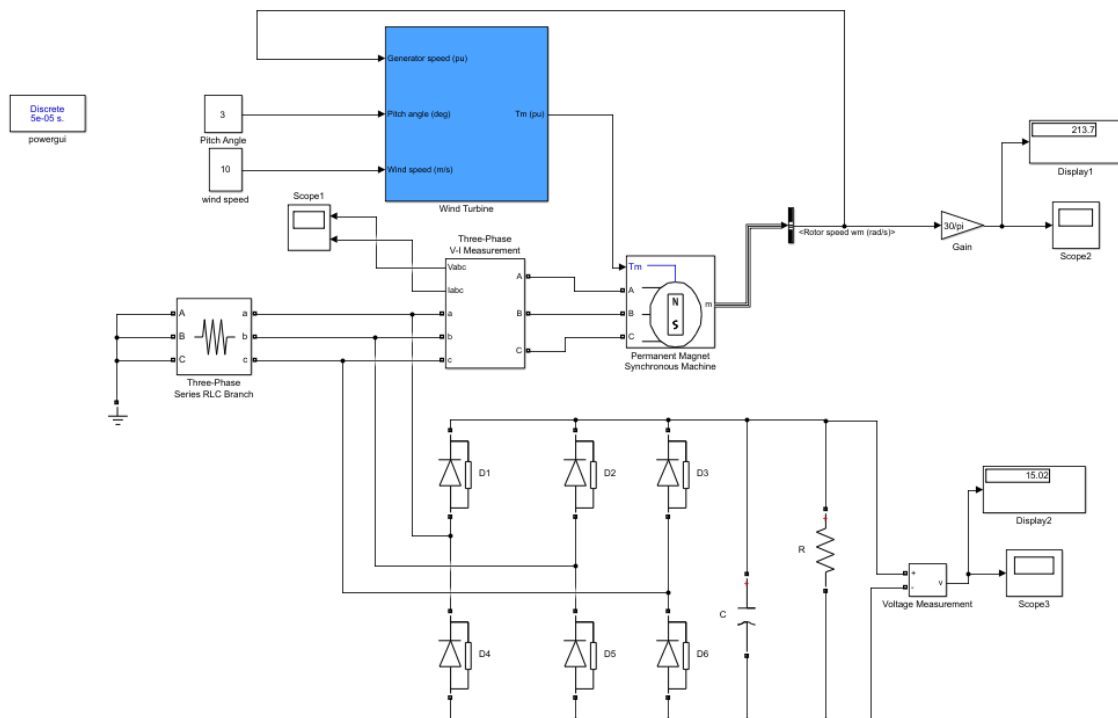

Figure 4.1. Simulink diagram of wind turbine subsystem

Table 4.1. Parameters of Wind turbine

Parameters	Blade Diameter	Number of Blades	Air Density	Rated Wind speed	Cut-in speed	Cut-out speed
Rating	8.4 m	3	0.55kg/m ³	10m/s	2.5m/s	25m/s

Figure 4.2 shows the Simulation waveform of output power characteristics for various speed wind turbine. Figure 4.3 shows the AC voltages of wind energy system and the DC output voltage of the wind energy system is displayed in Figure 4.4. respectively

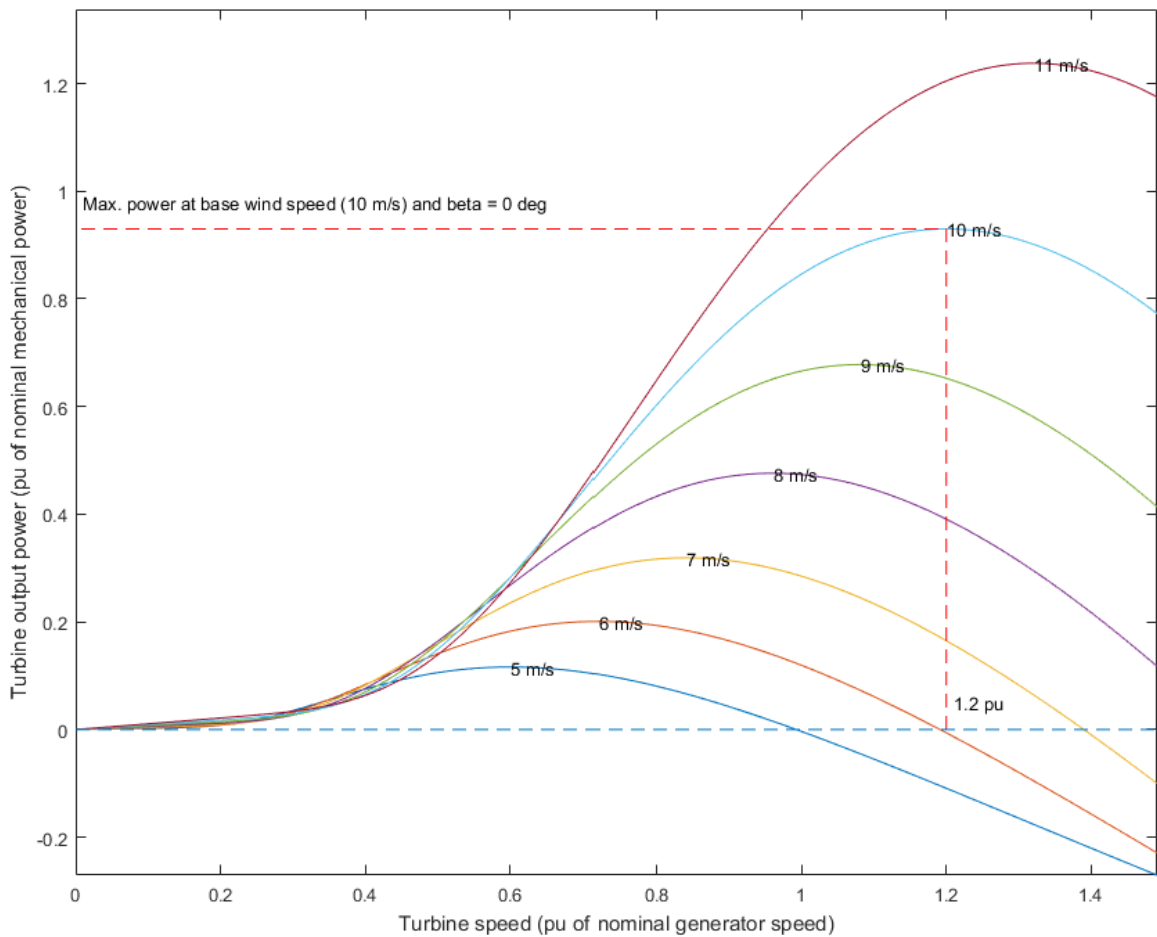

Figure 4.2. Power Characteristics of wind turbine

AC Voltages

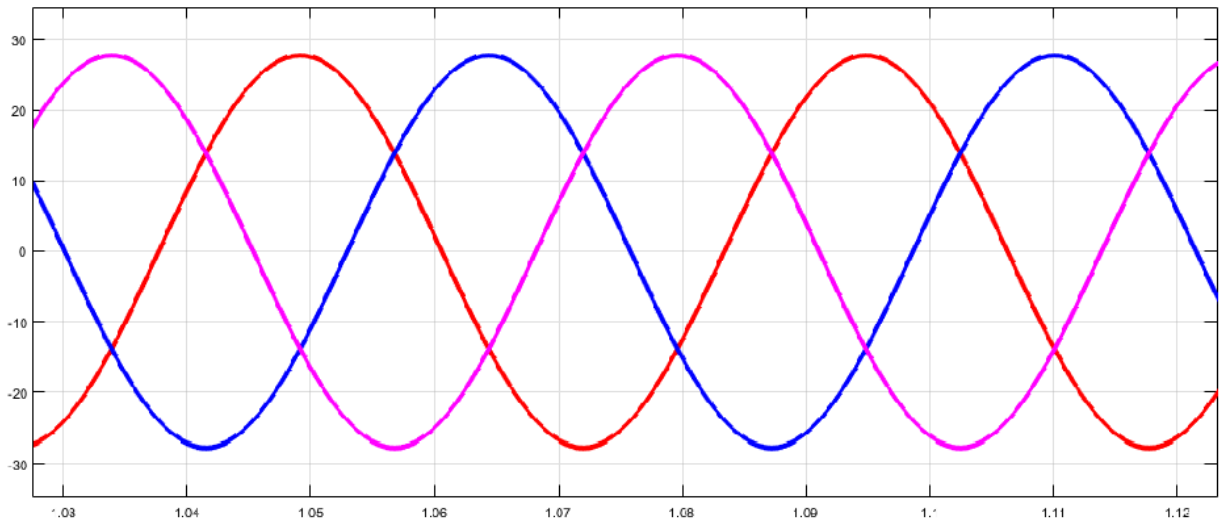

Figure 4.3. The AC voltages of wind Turbine

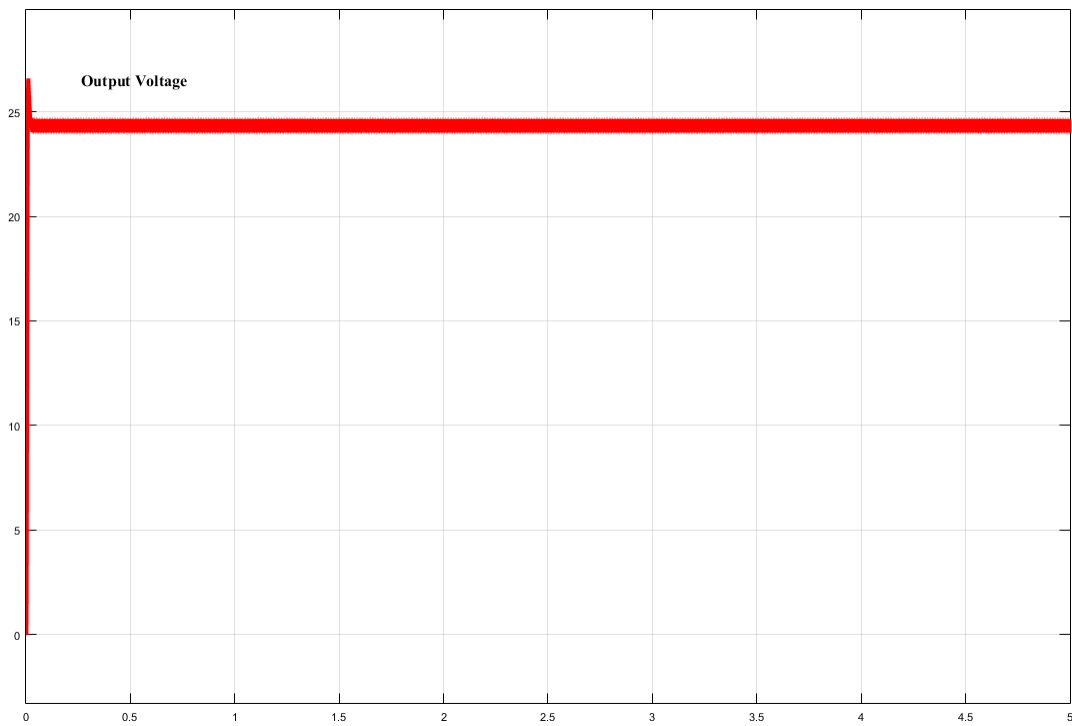

Figure 4.4. wind energy system Voltage Output

4.2.2. SOLAR PV SYSTEM

MATLAB/SIMULINK was used to model and simulate a solar PV system

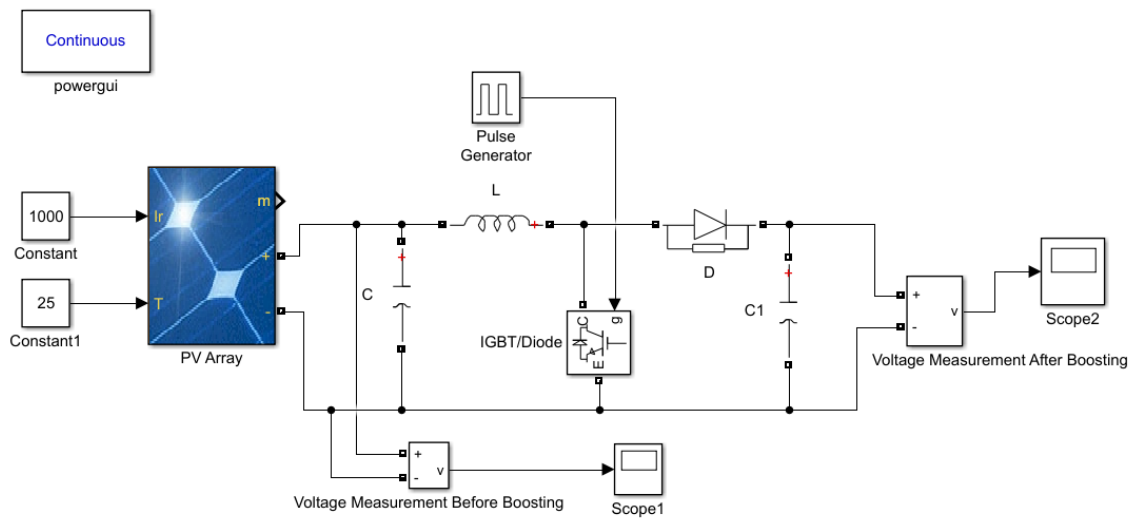

Figure 4.5. Solar PV subsystem Simulation diagram

Table 4.2. PV Module Parameters

P_{max}	V_{max}	T° Coefficient
400 W	37 V	25°C

Under various solar temperatures and irradianations, the solar photovoltaic module produces the DC voltage. According to figure 4.6, the energy generated by the PV modules is not remain the same; rather, it varies depending on the temperature and the intensity of the sun's photovoltaic rays.

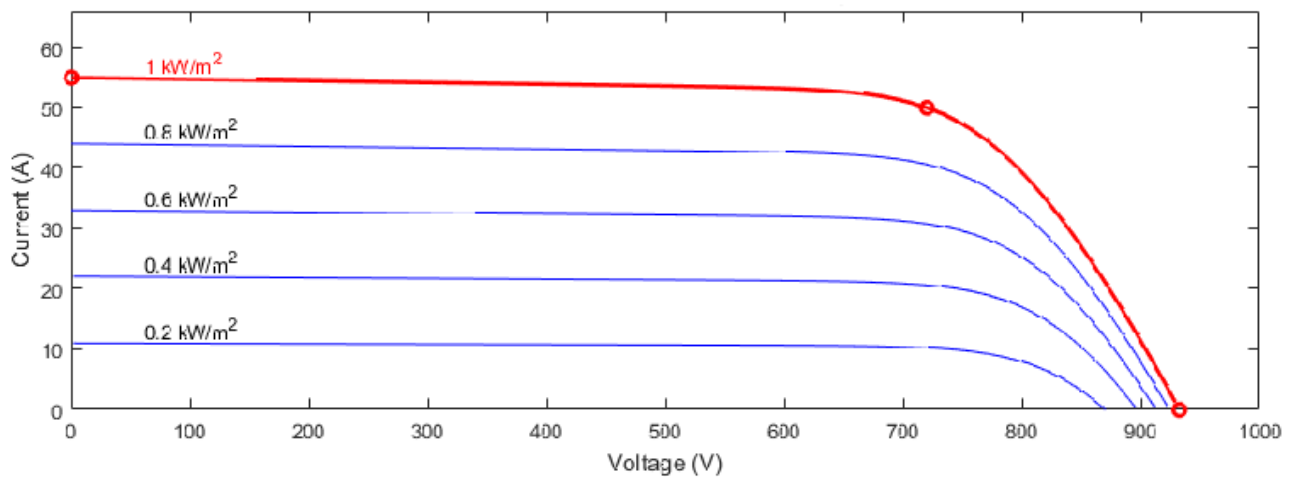

Figure 4.6. Voltage vs. Current characteristics

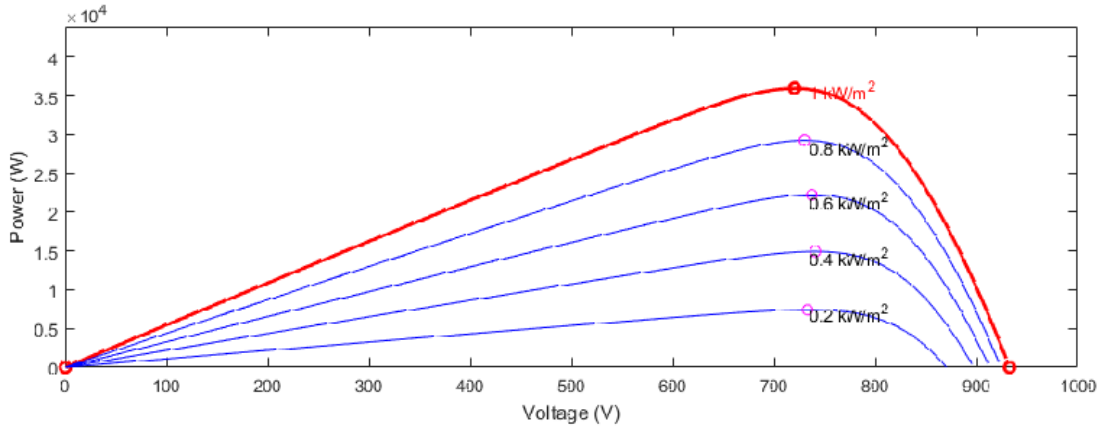

Figure 4.7. Power vs Voltage characteristics

The below figure shows Voltage output of PV System at 1000 W/m^2 before boosting the voltage

- In atmosphere, temperature is not constant. It is varying from morning to evening right. In afternoon time, only we are getting the maximum power but in the morning time and evening time, we are getting the low power right but any time we need to give the load to constant supply for 24 hours. Therefore, we need to boost up the voltage, to increase the voltage whenever you are not getting the much voltage from solar panel due to cloud it is or rain time. Here, connect the boost converter to meet the load.

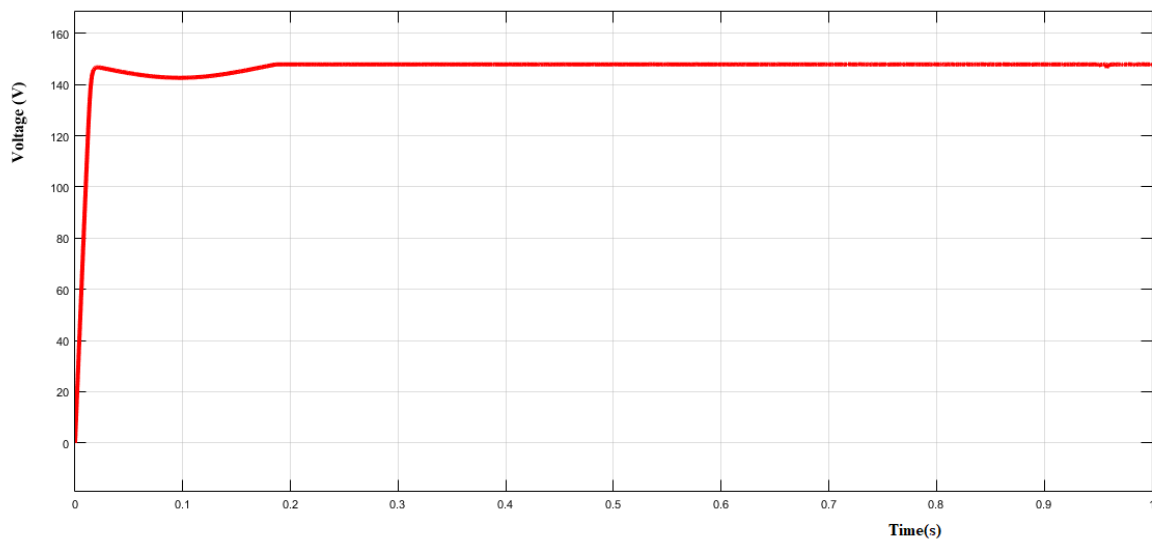

Figure 4.8. Output voltage of PV System before boosting

Output voltage of Photovoltaic System at 1000 W/m^2 after boosting the PV array output voltage is shown in the figure 4.8

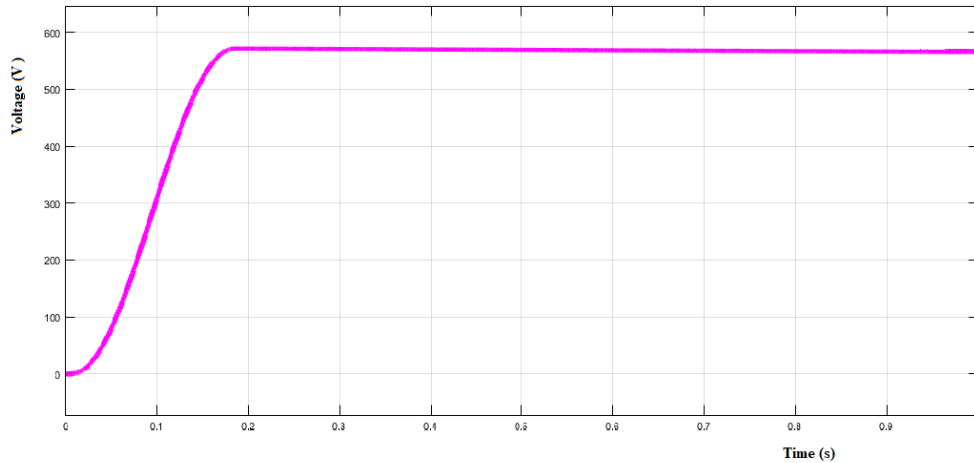

Figure 4.9. Output voltage of PV System after boosting

The voltage-power output characteristics and voltage-current relationship of a PV module under solar radiation $G = 1 \text{ kW/m}^2$, 0.8 kW/m^2 , 0.6 kW/m^2 , 0.4 kW/m^2 , 0.2 kW/m^2 and T° of 25°C is shown in fig 4.7 and 4.6 respectively. It has been noted that both output voltage and output current of PV systems are mostly depending on variations in temperature and irradiation right.

4.2.2.1. MAXIMUM POWER POINT TRACKING (MPPT)

The main idea behind MPPT is to operate PV modules at the most effective voltage (maximum power point) in order to get the most power out of them. That is to say: MPPT analyzes the PV module output, compares it to the voltage of the battery, and determines optimal amount of power that the PV module can supply to charge the battery. To enable the battery to receive the maximum amount of current, it then transforms that power to the optimal voltage.

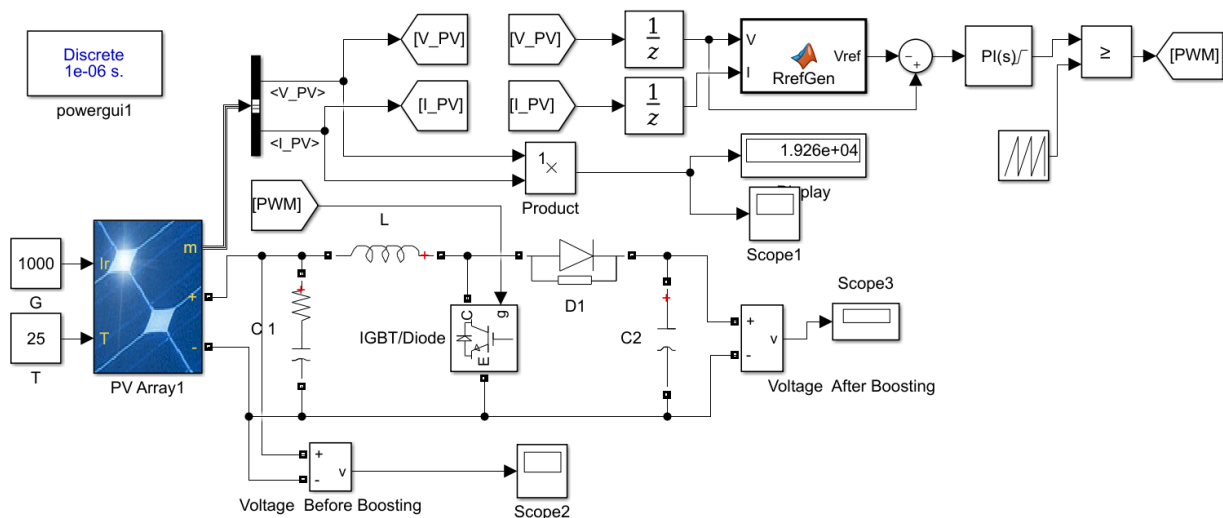

Figure 4.10. Maximum Power Point Tracking (MPPT) Using boost Converter

The output Power of PV systems is mostly depending on variations in temperature and irradiation right.

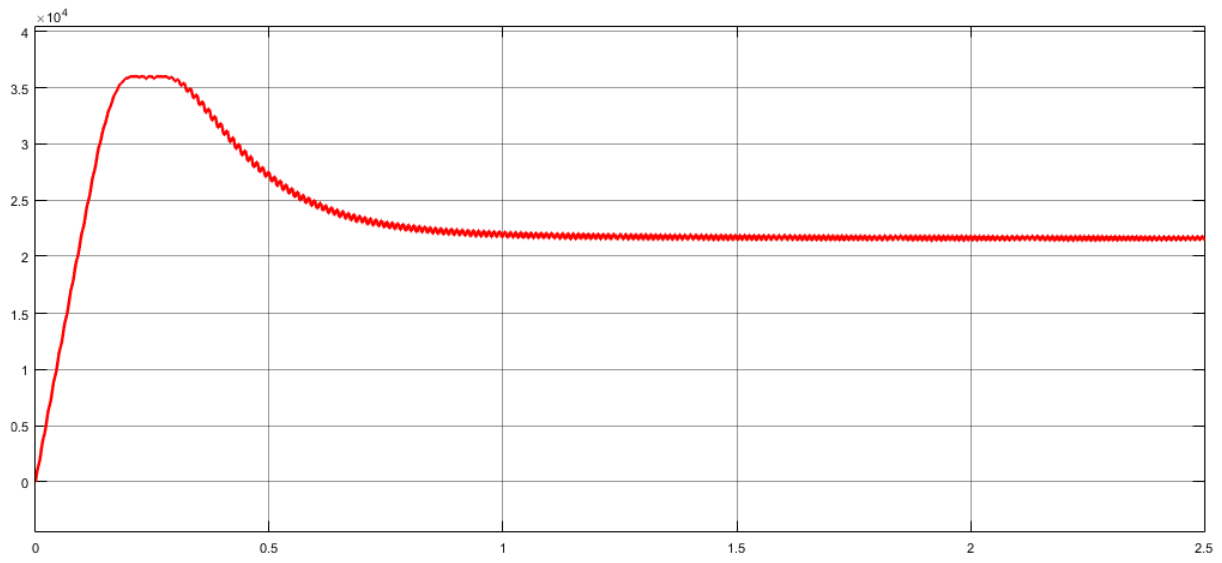

Figure 4.11. MPP for 1000 radiation

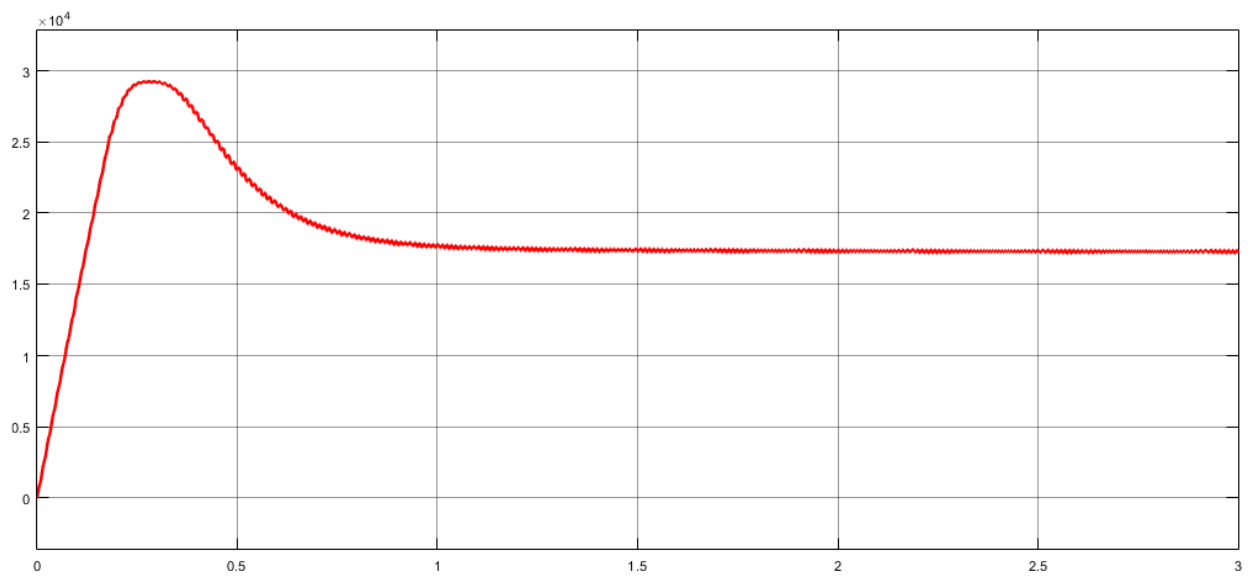

Figure 4.12. MPP for 800 radiation

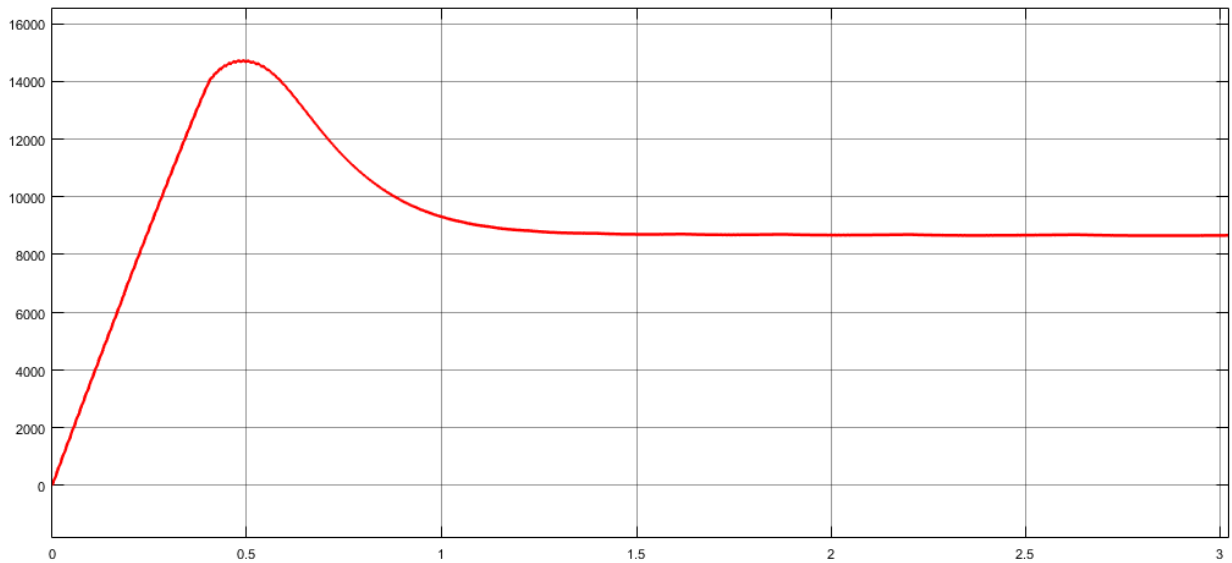

Figure 4.13. MPP for 400 radiation

4.3. Hybrid System

In this situation, solar PV and wind system are both used to meet the demand. Their Output Voltages are combined with a universal bridge to generate a 230 V as output Voltage.

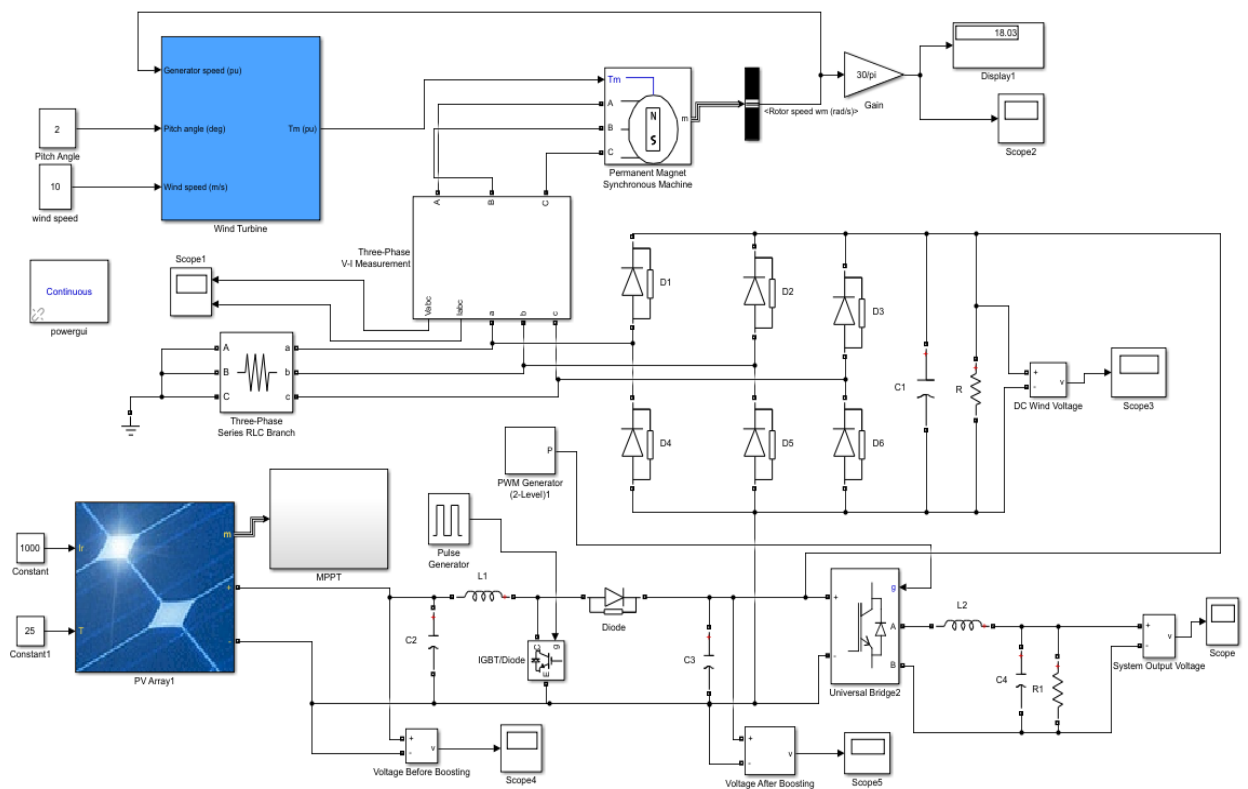

Figure 4.14. Hybrid system Simulation model

- ❖ The DC output Voltage is converted to AC using Universal Bridge, which works as Inverter and Passive filter.

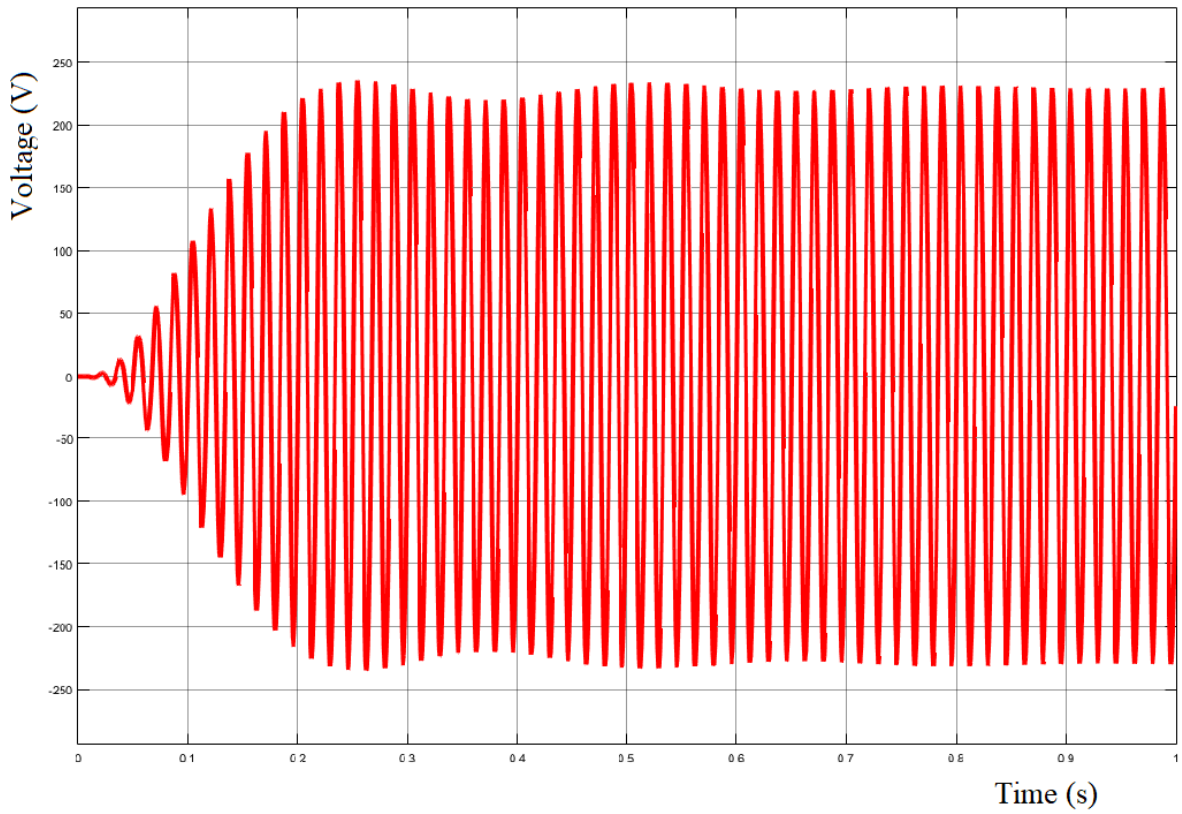

Figure 4.15. Output voltage for wind (10 m/s) and Solar PV (1000W/m²)

CHAPTER 5: CONCLUSION AND RECOMMENDATIONS

5.1. Conclusion

The design of a solar-wind hybrid power system for 300 households in the remote area of Nyamagabe district has been devoted in this thesis study. Nyamagabe District's wind recorded 7.6 m/s wind speed and the horizontal solar radiation was 7.54 kWh/m²/day. These data were examined using MATLAB SIMULINK, and the outcome shows that it is absolutely feasible to take advantage of wind and solar energy potentials for producing electricity as a hybrid system.

By paying close attention to the country's electricity shortage, the community's rural lifestyle, which is still significant to many Rwandans, will be improved such as education, commercial activities. The system is also friendly to the environment. Every Rwandan must have access to inexpensive electricity, according to the Government's strategy; This significant aspect needs to be considered. Government support is highly needed to establish this power generating system.

Finally, I could say that this hybrid power system is a superior alternative to currently available alternatives and it is less expensive and more appealing than the electricity from the grid. For the electrification of the selected rural community, given that the system will be maintained by local, qualified workers and compared to the national grid, the hybrid system will have considerably lower energy costs.

5.2. Recommendations

There are renewable energy resources spread out around the whole country, which vary from site to site, and may be used to generate electricity in on-grid or off-grid systems. The country's power crisis is reduced with the use of off-grid solutions to generate electricity from local renewable resources. However, the implementation of such systems will still confront a number of difficulties, including those relating to infrastructure, community finances, investor risk-taking, lack of knowledge of how to exploit renewable resources, and other associated problems. Renewable energy technology systems, both on and off - grid, need to be promoted by utilizing various strategies in order to reduce the energy deficit at the national level. If land degradation, environmental pollution, and low living standards in rural communities are given the necessary attention, Renewable energy and hybrid technology should be used. PV standalone systems for individual residences are introduced, although they are unreliable and unsustainable. Therefore, more renewable energy sources, such as solar, wind, or hybrid systems, might be more economical implemented due to the nation's electricity demand.

REFERENCES

- [1] REG, "RWANDA AND JAPAN CELEBRATE COOPERATION IN ENERGY SECTOR DEVELOPMENT," *Newsletter*, January- March, 2023.
- [2] NISR, POPULATION AND HOUSING CENSUS, Kigali, 2022.
- [3] N. U. H. a. N. A. Aqsa Naeem, "Design of Solar-Wind Hybrid Power System by using Solar-Wind Complementarity," Lahore, Pakistan, 2020.
- [4] N. A. B. Berino Francisco Silinto, Feasibility Study of Solar-Wind Hybrid Power System for Rural Electrification at the Estatuene Locality in Mozambique, 2015.
- [5] M. A. a. C. B. Fadi Al-Turjmana, "Feasibility analysis of solar photovoltaic-wind hybrid energy for household applications," 2020.
- [6] A. A.-H. ., M. A. a. R. A.-A. Abdullah Al-Shereiqli, "Optimal Sizing of Hybrid Wind-Solar Power Systems to Suppress Output Fluvtuation," 2021.
- [7] C. W. W. a. M. K. M. '. NISINGIZWE Emmanuel, Design of Solar–Wind Hybrid System for Rural Electrification in Rwanda, 2014.
- [8] T. Abrar, M. Shabbir and O. Siddiqui, WIND & SOLAR RENEWABLE ENERGY, 2016.
- [9] N. G. UCAR, "<https://scied.ucar.edu/learning-zone/how-climate-works/energy-budget>," [Online].
- [10] P. C. S. p. Kousik Ghosh, Solar and Wind Hybrid Power Generation.
- [11] C. M. YANDIOLA, Feasibility Analysis of the use of the use of Hybrid Solar PV-Wind Power Systems for Grid integrated Mini-grids in India.
- [12] A. Lavaa, "Everything You Need to Know About Monocrystalline Solar Panel," 2023. [Online].
- [13] J. A. Salah, Basics of solar PV system.
- [14] "https://ccsuniversity.ac.in/bridge-library/pdf/ME_1.SOLAR%20CELL.pdf," [Online].
- [15] M. S. A.-E. M. M. Salama Abdelhady, "An understanding of the operation of silicon Photovoltaic Panels," 2016.
- [16] A. L. a. S. Hegedus, Handbook of photovoltaic science and engineering, second edution, 2011.
- [17] T. N. 2022, "<http://commons.wikimedia.org/wiki/File:Pn-junction-equilibrium.png>," [Online].
- [18] N. S. a. A. Goswami, "Study of P-V and I-V Characteristics of Solar Cell in MATLAB/ Simulink," 2018.
- [19] A. L. a. S. Hegedus, Handbook of Photovoltaic Scienceand Engineering.

- [20] F. A. A. M. O. E.E. Iheonu, Wind Resources Variations over selected sites in the West African sub-region. Nigerian J. Renewable Energy,, 2002.
- [21] N. Vaezi, "Elimination of Pitch Signal Fluctuations Caused by Unbalanced Aerodynamic System in 100 kW Wind Turbine," 2019.
- [22] S.Mathew, Wind Energy: Fundamentals, Resource Analysis and Economcs, 2006.
- [23] B. Univeristy, "Mechanical Engineering Department," *Wind Turbines*, 2010.
- [24] P.Jain, Wind Energy EEngineering, 2011.
- [25] Electropaedia, "<https://www.mpoweruk.com> Wind Power," [Online].
- [26] -J. a. J. H, Introduction to Wind Energy System: Basics, Technology and Operation, Springer, 2009.
- [27] D.Chiras, Wind Power Basics: a Green Energy Guide, New Society Publisher, 2010.
- [28] W. Tong, Fundamentals of wind energy, 2010.
- [29] I. Sadrehighi, "Horizontal Axis Wind Turbines (HAWT) with Case Studies," February 2022.
- [30] M. Saad, "Comparison of Horizontal Axis Wind Turbines and Vertical Axis Wind Turbines," 2014.
- [31] J. F. M. a. J. G. McGowan, WIND ENERGY EXPLAINED: Theory, Design and Application, 2009.
- [32] A. A. ., M. D. H.M. Boulouiha, "Grid Integration of Wind Energy Systems: Control Design, Stability, and Power Quality Issues," 2017.
- [33] A. L. D. KUMARA E.A.D, DESIGN, FABRICATION AND TESTING OF A VAWT WITH WIND DEFLECTORS, 2014 .
- [34] M. E. D. A. (MEDA), "Small Wind Energy and Hybrid Systems Programme," 2023.
- [35] L.Weldemarian, GENSET-SOLAR-WIND HYBRID POWER SYSTEM OF OFF-GRID POWER STATION FOR RURAL APPLICATIONS, 2010.
- [36] D. Gielen, Electricity Storage and Renewables for Island Power, A Guide for Decision Makers, 2012.
- [37] M. M. Mahmoud, On the Storage Batteries Used in Solar Electric Power Systems and Development of an Algorithm for Determining their Ampere-Hour Capacity, 2009.
- [38] B. M. a. R. I. A. Kaabeche, "Optimal Sizing Method for standalone Hybrid PV/Wind Power Generation System. Revue des energies renouvelables," 2010, pp. pages 205-213.
- [39] O. J. Seraphim, Energy efficiency of photovoltaic modules mono and polycrystalline in function of global solar radiation (Eficiência Energética de Módulos Fotovoltaicos Mono e Poli-Cristalinos em Função da Radiação Solar Global.), 2004.

- [40] H.Haberlin, Photovoltaics System Design and Practice ,UK: Jhon Wiley &Sons Ltd, 2012.
- [41] G. a. N. Stapleton, Grid Connected Solar Electric System. New York, USA and Canada : Earthscan, 2012.
- [42] C. Davila, "<https://energieadvisor.org/>," 2023. [Online].
- [43] a. A. Godwin Norensense Osarumwense Asemota, "Shading Effects in Photovoltaic Modules: Simulation and Experimental Results," 2017.
- [44] T. A. Loehlein, Maintenance is one key to diesel genertor set reliability, 2007.
- [45] A. L. a. S. Hegedus, Handbook of Photovoltaic Science and Engineering SecondEdition, 2011.
- [46] N. Emmanuel, Investigationof Renewable Energy Potential for Rural Electrification in Rwanda, 2014.

APPENDIX: SOME SYSTEM ITEM SPECIFICATIONS

A. Solar Pv Specifications

Brand	Solar Power Supply
Artikelnummer	SPS 400
Type of Cell	Monocrystalline
Power	400 W
Voc	51,8 V
Imax	10 A
Vmax	40 V
Isc	11 A
Waterproof	Yes, IP65 rated for junction box and IP54 (= splash proof) for the solar panel.
Dimensions	1045 x 580 x 65 mm for Folded 1045 x 2345 x 15 mm for Unfolded
Weight	17,3 kg
Material	plastic, canvas

B. Wind Turbine specifications

Manufacturer	Wind turbines manufacturers (wind-turbine-models.com)
Power	15 kW
Cut-in wind speed	2.5 m/s
Nominal wind speed	10 m/s
Cut-out wind speed	25 m/s
Survival wind speed	50 m/s
Diameter	8.4 m
Swept area	55.0 m ²
blades	3
Rotor speed, max	90.0 U/min
Tip speed	40 m/s
Material	GFK
Gear box Type	Spur
Gear Box Stages	2
Generator Type	Asynchron
Generator Speed, max	1,450.0 U/min
Frequency	50Hz
Tower Hub height	17.6m
Tower Type	Rohmast
Tower shape	Zylindrisch/konisch

C. Charge Controller Specification

Model	100A	
Manufacturer	Sunchonglic	
Charging Method	Maximum power, quick charge, balanced charge, and float charge are all tracked by MPPT.	
Battery type	Lead Acid	(12V/24V/36V/48V/96V Auto+Adjustable 12V/24V/36V/48V/60V/72V/84V/96V)
Module Voc	0-230V	
The charging current can be adjusted	0-100A	
Start charging	PV voltage is higher than the battery voltage +3 volts (low current charging during cloudy days)	
Direct charging current output function	DC continuous output 100A	
Working environment temperature	-20°C-40°C	
Display communication	LCD display with touch button	
	8-pin RS485 communication interface	
Temperature compensation	To extend the life of the battery, the charging voltage and current are automatically adjusted based on the battery's temperature.	

D. Inverter Specifications

Model	ML200K	
Manufacturer	Mile Solar	
Power	200KW	
Input	DIRECT CURRENT VOLTAGE	360VDC/384VDC
	PHASE	3 Phase 4 wire and ground
	AC Voltage	380V±20%(3 phase), Single phase 220V
	Frequency	45-65Hz
	Rectifier Type	3 phase ,6 pulses, 12 pulses is optional
Output	PHASE	3 phase 4 wire + ground
	Waveform	Pure sine wave
	AC Voltage	380/400/415V
	Transient Response	±5%,10ms
	Frequency	50/60 Hz ±0.05%
	Total-harmonic distortion	< 3% linear load, <5%(nonlinear load)
	Overload Capacity	Overload 125% for 10 Mins, 125%-150% for 1min, automatically resume when the load becomes normal
Bypass	Type	Static state +manual maintenance bypass
	Input Phase	3 phase 4wire and ground
Efficiency	Whole unit	>85%
	Inverter	93%