



UNIVERSITY of  
RWANDA

***Research and Postgraduate Studies  
(RPGS) Unit***

---

**Thesis Title: SMART WASTE MANAGEMENT SYSTEM**

***Case Study: MUGONERO District Hospital***

By:

KAMANAYO Ananie

***Reg\_Number: 220020398***

College of Science and Technology

School of Information and Communication Technology (SoICT)

Master of Science in Software Engineering.

A dissertation submitted in partial fulfilment of the requirements for the degree of Master of  
Science in software engineering.

June 2024

---

## **DECLARATION**

I, KAMANAYO Ananie hereby declare that this project named “Smart Waste Management System” is my original and has never been submitted to any school. Was implemented from my own effort and is submitted in the fulfilment of requirement of the award of Master of Science in Software Engineering and it has never been presented or submitted in any Institution.

**KAMANAYO Ananie**

**Ref: 220020398**

**Signed: .....**

**Date: ...../...../.....**



**Certificate**

This is to certify that the project work entitled “Smart Waste Management System” is a record of original work done by KAMANAYO Ananie with Reg no: 220020398 in partial fulfillment of the requirement for the award masters of science in Software Engineering of College of Science and Technology, University of Rwanda during the academic year 2020-2022.

Signature.....

Date ...../...../2024

Student name: KAMANAYO Ananie

**Supervisor**

**Post graduate coordinator    School of ICT**

Prof. Damien HANYURWIMFURA

Dr. Frederic NZANYWAYINGOMA

Signature:.....

Signature :.....

Dr.MASABO Emmanuel

Signature :.....

## **ACKNOWLEDGEMENTS**

First and foremost, I deeply thank the Almighty God for the gift of life and spirit of hard working. I sincerely thank Prof. Damien HANYURWIMFURA and Dr.MASABO Emmanuel, who were my guiders and supporters in this project, for their constant support through the course and day to day advices provided by them, your advices, guidance, support were highly appreciated.

May God bless you!

## **ABSTRACT**

Efficient garbage monitoring and waste management pose significant challenges in many hospitals in Rwanda. The existing systems are notably ineffective, leading to suboptimal waste management and collection processes. In several hospital departments, overflowing dustbins are a common sight, attributed to inadequate monitoring and collection. This situation not only results in unpleasant odours, but also poses a risk of infection spread. Timely and regular waste collection is vital in hospital settings to prevent overfilled bins and potential exposure. To deal with these problems, this study proposes the implementation of a "Smart Waste Management System" tailored for hospital environments. The core component of this system is the ESP8266 microcontroller. Ultrasonic sensors are employed to monitor the waste level within dustbins and providing insights into the quantity and type of waste to be disposed in the bins. The collected data is then transmitted by the ESP8266 to a web application, where it is visually represented for easy interpretation. The implementation of the smart hospital waste management system yields promising results. By employing real-time monitoring and data visualization, the system effectively addresses the inefficiencies of traditional waste management in hospitals. The data transmission to the web application facilitates prompt decision-making and intervention. Ultimately, the smart waste management system emerges as a viable and efficient solution to enhance waste management practices in hospital settings.

### ***Keywords:***

IoT, Hazardous waste, infectious waste, chemical waste, smart dustbin.

## **LIST OF ACRONYMS**

**AIDS:** acquired immune deficiency syndrome

**DHT:** Distributed Hash Table

**ESP:** Event Stream Processing

**HIV:** human immunodeficiency virus

**IoT:** Internet of Things

**LCD:** Liquid Crystal Display

**PHP:** Hypertext Preprocessor

**WHO:** World Health Organization

**Wi-Fi :**Wireless Fidelity

## LIST OF FIGURES

Figure 3.1:Agile model process .....	11
Figure 3.2:prototyping model .....	13
Figure 3.3:basic layered architecture .....	15
Figure 3.4:ultrasonic distance sensor .....	17
Figure 3.5:Capacitive Soil Moisture Sensor .....	17
Figure 3.6:Servo Motor.....	18
Figure 3.7:Nodemcu(esp8266) .....	19
Figure 3.8:printed circuit board .....	19
Figure 3.9:universal serial connector .....	19
Figure 3.10:Arduino Uno .....	20
Figure 3.11:architecture diagram of garbage monitoring using iot .....	21
Figure 4.1:System hardware design .....	24
Figure 4.2:System user login interface .....	25
Figure 4.3:Admin system dashboard .....	25
Figure 4.4:System Functional Diagram .....	26
Figure 4.5:system User case Diagram .....	27
Figure 4.6:ERD system diagram.....	28
Figure 4.7:Flowchart system Diagram.....	29
Figure 4.8:system User Roles .....	30
Figure 4.9:User identification .....	30
Figure 4.10:Dust Status.....	30
Figure 4.11:Dustbin report.....	31
Figure 4.12:System class diagram .....	31
Figure 4.13:Activity diagram.....	32
Figure 5.1:System User registration form.....	34
<i>Figure 5.2:System user personal information page.....</i>	<i>34</i>
Figure 5.3:System collector registration form .....	35

Figure 5.4: System user credentials login .....	36
Figure 5.5: Dust bin creation form.....	36
Figure 5.6: List of registered dustbins .....	37
Figure 5.7: System dustbin report .....	37
Figure 5.8: Dust bin in Empty level status.....	39
Figure 5.9: Dust bin in Middle level status.....	39
Figure 5.10: Dust bin in Full level status.....	40
Figure 5.11: Email alert from system .....	41

## Contents

DECLARATION .....	i
Certificate.....	ii
ACKNOWLEDGEMENTS .....	iii
ABSTRACT.....	iv
LIST OF ACRONYMS .....	v
Contents .....	viii
Chapter 1. GENERAL INTRODUCTION.....	1
<b>1.1 Introduction</b> .....	1
<b>1.2 Background and Motivation</b> .....	2
<b>1.3 Problem Statement</b> .....	3
<b>1.4 Study Objectives</b> .....	3
<b>1.4.1 General Objective</b> .....	3
<b>1.4.2 Specific Objectives</b> .....	3
<b>1.5 Significance of the Study</b> .....	5
<b>1.5.1 To the Researcher</b> .....	5
<b>1.5.2. To the Users</b> .....	5
<b>1.6 Organization of the Study</b> .....	5
<b>1.7 Conclusion</b> .....	6
Chapter 2. LITERATURE REVIEW .....	7
Chapter 3. RESEARCH METHODOLOGY .....	10
<b>3.1.Introduction</b> .....	10
3.2. Observation .....	10
<b>3.3. System Development techniques and model to be used</b> .....	11
<b>3.3.1 Programming</b> .....	11
<b>3.3.2. Software development model to be used</b> .....	11
3.4. The Waste Management Solution for Citizens .....	13
<b>3.4.1. The Waste Management System IoT Architecture Reference Model</b> .....	14
<b>3.4.2. Architecture of My Waste Management System</b> .....	16
<b>3.5 Smart waste monitoring and clearance system using internet of things</b> .....	20

Chapter 4. SYSTEM ANALYSIS AND DESIGN .....	22
<b>4.1. System Analysis</b> .....	22
<b>4.1.1. System requirement</b> .....	22
<b>4.1.2 Current system</b> .....	23
<b>4.1.3 Proposed system</b> .....	23
<b>4.1.4 System Hardware design</b> .....	23
<b>4.2. System Design</b> .....	24
<b>4.2.1 User interface:</b> .....	24
<b>4.2.2 Functional Diagram</b> .....	26
<b>4.2.3 Use Case Diagram</b> .....	27
<b>4.2.4 Entity Relationship Diagram(ERD)</b> .....	27
Chapter 5. RESULTS AND ANALYSIS .....	33
<b>5.1. Introduction to the System:</b> .....	33
<b>5.2. User Demographics and Roles:</b> .....	35
<b>5.3. System Access and Permissions:</b> .....	35
<b>5.4. Challenges and Solutions:</b> .....	37
<b>5.5. System Performance Metrics:</b> .....	38
<b>5.6. Result Discussions</b> .....	42
Chapter 6. CONCLUSION AND RECOMMENDATION .....	45
LIST OF REFERENCES .....	47
APPENDIX I .....	52
Appendix II .....	55

## **Chapter 1.GENERAL INTRODUCTION**

### **1.1 Introduction**

Hospital waste is “any waste generated during the diagnosis, treatment or vaccination of humans or during research” in a hospital. “Hospital waste is a special type of waste that is generated in small quantities and has a high potential for infection and injury”. Improper disposal of hospital waste can have serious health consequences from a public health perspective. Hospital waste management is defined as “the management of waste generated by hospitals using techniques that control the spread of diseases through hospital waste and includes both hazardous and non-hazardous waste. In general, hazardous waste includes infectious, pathological, pharmaceutical, sharps, chemicals, Geno-toxic, and radioactive waste[1]. Ordinary waste is household and everyday waste consisting of leftover food and associated packaging. Operational procedures related to waste disposal, such as in developed countries, have well-implemented hospital waste management systems. A well-trained team is responsible for conducting various attentions in developing countries. Separation of hazardous waste “Procedures. Medical waste disposal has not been comprehensively, and disposed of final disposal. However, the situation is not good in developing countries [2].

There is also a shortage of non-hazardous waste management and this is generally not done. Cleaners and employees are unaware of the risks they face and of health policies and legislation[3].

Several studies have explored the use of IoT in waste management, including medical waste management. A study conducted by Kuo and colleagues (2020) in Taiwan used an IoT-based waste management system to monitor and manage medical waste in hospitals, which resulted in a significant reduction in waste volume and improved operational efficiency. Another study by Chen and colleagues (2019) in China developed an IoT-based waste management system for a hospital, which improved waste segregation, reduced waste volume, and lowered the risk of infectious diseases.

A smart waste management system implemented in Mugonero District Hospital is a significant step towards improving waste management practices in healthcare facilities in Rwanda and beyond. The system has the potential to improve waste segregation, reduce waste volume, and enhance the safety and sustainability of waste management practices in healthcare facilities[4].

## 1.2 Background and Motivation

- A growing population and economy, which means an increase in waste generated. This puts pressure on already scarce waste disposal facilities.
- Increased complexity of the waste stream due to the high number of patients in hospitals. The complexity of the waste stream directly affects the complexity of its management, which is compounded when hazardous waste is mixed with non-hazardous waste[3].
- Limited understanding of the key waste streams and hospital waste budgets as reporting waste data reporting is not mandatory and available data is often unreliable and inconsistent[5].
- A political and regulatory environment that does not actively promote the waste management hierarchy. This has limited the economic potential of the waste management sector. The waste collection and recycling industry is an important contributor to employment and has further potential for growth[5].
- Increasing pressure on aging waste management infrastructure with falling investment and maintenance costs[6].
- Waste management suffers from widespread underpricing, which means that the costs of waste management are not fully recognized by consumers and industry, and waste disposal is preferred over other options.
- Few waste management options are available, so they are more expensive than landfill costs.
- There are insufficient appropriate and compliant landfills and facilities for the disposal of hazardous waste, making it difficult to safely dispose of all waste streams. Although the number of waste treatment plants is estimated at over 2,000, a significant number are unlicensed.

### **1.3 Problem Statement**

The main problem in the disposal of biomedical waste is the lack of knowledge of hospital and healthcare facility staff about the separation and disposal of biomedical waste.

The poor waste collection, and storage of neutralized waste led to poor management of biomedical waste, resulting in potential environmental pollution and bad odour. The growth and multiplication of infectious vectors such as parasites, rodents, and worms are likely to result in the transmission of diseases such as cholera, hepatitis, typhoid, and AIDS through needle stick and syringe injuries. Contaminated by human biomedical waste, they have become a reservoir of infectious diseases, if not properly managed and disposed of. Medicinal organic waste strewn in and around healthcare facilities, contaminated by flies, insects, rodents, etc. WHO is responsible for the spread of communicable diseases such as plague, rabies, hepatitis A&E... Eye cleaners in health facilities and pathology anatomy laboratories, separate waste collection is potentially exposed to tetanus and HIV infection, hepatitis A&E. infections. The WHO has stated that 85% of hospital waste is actually non-hazardous waste, about 10% is infectious waste and about 5% is non-infectious but hazardous waste. The problem of disposing of biomedical waste in hospitals and other healthcare facilities has become a topic of growing interest; This points to the urgent need to develop a safe, cost-effective and environmentally friendly disposal system for biomedical waste in hospitals and other healthcare facilities [7].

### **1.4 Study Objectives**

#### **1.4.1 General Objective**

The main objective of this project is to design and implement a smart waste management system that solving issues related to waste collection, monitoring, and bin distribution that have previously led to ineffective management of biomedical waste at MUGONERO District Hospital. These problems include inadequate waste segregation based on type, inefficient bin tracking, and lack of real-time monitoring, resulting in potential environmental pollution and unpleasant odors. .

#### **1.4.2 Specific Objectives**

- To gather system requirements.
- To design a system for real-time monitoring of waste disposal activities.

- To develop a circuit with NodeMcu, Ultrasonic distance Sensor, Soil Moisturize sensor combined with infrared to separate the waste type.
- To evaluate the performance and functionality of the smart waste management system in real world setting.

The use of bins equipped by IoT sensors and other devices will facilitate in monitoring and collection of waste data in Mugonero District hospital and that will improve the waste efficiency management, reduction the environmental impact, and enhance the health and safety of the staff and patients.

### **Study Scope**

Mugonero District Hospital is located in KARONGI district of the Western Province of Rwanda. Waste management and monitoring systems using IoT technology are being implemented in healthcare facilities worldwide, including in Rwanda.

In Rwanda, healthcare waste is regulated by the Ministry of Health, and a national waste management policy and strategy have been developed to guide the management of healthcare waste. The policy emphasizes the importance of proper segregation, collection, transportation, treatment, and disposal of healthcare waste to protect public health and the environment [8].

Mugonero District Hospital has to implement a waste management system that includes the use of IoT technology for monitoring and tracking the collection and disposal of healthcare waste. The system should include sensors installed on waste bins that detect when the bins are full and notify waste management personnel when they need to be emptied. This technology helps to ensure that waste is collected and disposed of in a timely and efficient manner, reducing the risk of contamination and infection[9].

In addition to IoT technology, Mugonero District Hospital has also implemented other waste management practices, including segregation of waste at the source, use of appropriate waste containers[10].

## **1.5 Significance of the Study**

### **1.5.1 To the Researcher**

Our system will help us to improve our ability, knowledge, and experience in implementing different automated system.

### **1.5.2. To the Users**

This system will provide better way of fighting against wastes that are being overflowed in hospitals due to late cleanup of the dustbin

## **1.6 Organization of the Study**

This thesis is structured into six distinct chapters, each contributing to a comprehensive understanding of the research topic and its implications. The organization of the thesis is designed to guide readers through the research process, from establishing the context and objectives to presenting findings, analysis, and conclusions.

Chapter 1: In this chapter, we provide an introduction to the project, which encompasses a detailed background description. We present a comprehensive problem statement that elucidates various issues with the existing system. Additionally, we outline the objectives of implementing the new system and delineate the specific scope within which the new system will operate. Chapter 2: This chapter comprises a thorough literature review of the project. We conduct a review and analysis of related projects to identify pertinent information and project requirements essential for our study. Chapter 3: Here, we elucidate the methodologies employed for data collection. This section provides a detailed description of all research methodologies utilized, along with an explanation of the various tools employed in the information gathering process. Chapter 4: The focus of this chapter is on system analysis and design. We elaborate on our system models, proposed simulation models, simulation parameters, and simulation scenarios to provide insight into the structure and functioning of the system. Chapter 5: This chapter is dedicated to presenting the results and analysis derived from our study. We offer a comprehensive explanation of our findings and provide graphical representations of the results obtained for clarity and better understanding. Chapter 6: In the final chapter of this report, we bring the project to a conclusion by summarizing our findings and recommendations. We offer insights into the significance of the work done and suggest potential areas for further exploration and improvement.

## **1.7 Conclusion**

In this introduction the idea and significance of hospital waste management, as well as the challenges and opportunities of using IoT-based systems was introduced. Gaps were highlighted and the reviews done for existing literature also gaps and limitations have been presented. I have also stated the research problem, objectives, questions, and hypotheses that will guide this study. I will present the theoretical framework and research methodology that I will use to conduct my project in the next chapter.

## Chapter 2.LITERATURE REVIEW

*Jeyanthi et al.*, [11], they proposed a system for food waste collection because local governments manage food wastes by deploying food waste bins and employing multiple pick-up business for food waste collection but researchers proposed a system to solve this manual collection but they failed to show whether their bins are full or not [11].

*P. K. Dutta* [12], has figured out a problem in a village of waste deployed everywhere in their village and they proposed a system to monitor those wastes as mentioned above but they failed to indicate to villagers whether the waste bins are full or not people keep on throwing waste in those bins even when they are full[12].

*M. Thamarai et al.*, [8], they proposed an automatic waste segregation method for household waste and classified the waste into metallic, dry, and wet waste. They used a parallel resonant impedance sensing mechanism to identify metallic waste and capacitive sensors to identify dry waste and wet waste. However, the method has limitations due to the capacitive sensors and needs to be more suitable for mixed waste classification. The waste classification was done using three modules image acquisition[8].

*N. A. Ismail et al.*, [13],their project proposes an IoT-based healthcare waste management system for hospitals. The system uses sensors to detect the level of waste in the bins and sends a notification to the hospital staff when the bin is full. The system also provides real-time monitoring of waste generation and disposal. The proposed system can help hospitals to reduce the risk of infection and ensure efficient waste management[13].

The project published on *ScienceDirect* they presented a smart garbage management system for hospitals. The system uses RFID technology to track the movement of waste bins and monitor their fill level. The system also provides a mobile application for hospital staff to manage the waste disposal process. The proposed system can help hospitals to optimize their waste management process and reduce the risk of infection.

The project *D. Misra et al.*, [14] they featured an IoT-based waste management system for hospitals. The system uses ultrasonic sensors to detect the level of waste in the bins and sends a notification to the hospital staff when the bin is full. The system also provides real-time monitoring of waste

generation and disposal. The proposed system can help hospitals to ensure efficient waste management and reduce the risk of infection[14].

The project *IoT-Based Healthcare Waste Management System* presents an IoT-based healthcare waste management system. The system uses sensors to detect the level of waste in the bins and sends a notification to the hospital staff when the bin is full. The system also provides real-time monitoring of waste generation and disposal. The proposed system can help hospitals to optimize their waste management process and reduce the risk of infection[15].

The paper of *J. AhamedFathima et al.*, [16] proposed an IoT-based waste management system in hospitals that utilizes sensors and a mobile application to monitor and manage waste. The system includes separate bins for different types of waste, and the sensors detect the level of waste in each bin. The mobile application provides real-time data on the waste level and sends notifications to the staff when a bin needs to be emptied[16].

*S. Sivasankar et al.*, [16]) in their paper presents on IoT-based smart waste management system for hospitals that uses sensors to monitor the waste level and a mobile application to alert the staff when a bin needs to be emptied. The system also includes a machine learning algorithm to predict the future waste generation rate and optimize the waste collection schedule[16].

*N. Prabhu et al.*, [17] proposed a system for hospitals that utilizes sensors to detect the level of waste in each bin and a mobile application to monitor the waste level and schedule waste collection. The system also includes a machine learning algorithm to predict the future waste generation rate and optimize the waste collection schedule.

*S. K. Yadav et al.*, [18] presented an IoT-based waste management system for hospitals that uses sensors to detect the level of waste in each bin and a mobile application to monitor the waste level and schedule waste collection. The system also includes a dashboard for real-time monitoring of the waste level and a database to store and analyze the waste data[18].

In this paper of *S. Gupta et al.*, they proposed an IoT-based smart waste management system for hospitals that uses sensors to monitor the waste level and a mobile application to alert the staff when a bin needs to be emptied. The system also includes a machine learning algorithm to predict the future waste generation rate and optimize the waste collection schedule. Additionally, the paper discusses the potential benefits of the system, such as cost savings and improved hygiene.

Previous works in this area have focused on using sensors to detect and monitor different aspects of the environment, but there is a gap of research on how these sensors can be integrated and used in combination to improve system performance. Our approach addresses this gap by developing a framework that combines and utilizes different sensors to create a more comprehensive and efficient system.

As proposed solution our project stands out by developing a unique system architecture that not only collects and analyzes data but also integrates it with other processes to improve system performance and efficiency our approach to waste management in hospital here in Rwanda is unique in that the researcher will use a variety of combination of ultrasound sensors and infrared to effectively of waste type separation and monitoring.

## **Chapter 3. RESEARCH METHODOLOGY**

### **3.1. Introduction**

This chapter explains methods to be used to collect data during research and software tools. This part of the project illustrates how the research project will be conducted. It clarifies the research methods to use during the development of this project like planning, data collection, system design, and implementation, and system testing [19].

A satisfactory result is obtained by the good choice of methods and techniques used for the collection of data. For creation of that in this project, the researcher puts clarification on methods and techniques to use to observe the reality of the current system and to reach predetermined objectives. Through this research, the researcher will use an internet-based method, interview, observation and documentation in order to collect needed data and carry out proper documentation[20].

Moreover, documentation plays a crucial role in consolidating information and refining the researcher's understanding. The researcher has diligently reviewed various books and explored internet resources to acquire comprehensive and factual information essential for the study's success [21]. Lastly, the methodology emphasizes cooperation as a research method to build trust and rapport among project stakeholders. This collaborative approach not only enhances the reliability of the collected data but also empowers participants by involving them in the research process, allowing their perspectives to shape the findings and recommendations [21]. In summary, the chosen techniques collectively contribute to a robust and multifaceted approach for data collection in the implementation of the Smart Waste Management System in Mugonero District Hospital.

### **3.2. Observation**

Using observation as a methodology in the development of a Smart Waste Management System for Mugonero District Hospital involves carefully observing users and system interactions in real-world settings[22].

By employing observation as a methodology, developers can gain valuable insights into the existing waste management practices at Mugonero District Hospital, ensuring that the Smart Waste Management System effectively addresses the unique challenges and requirements of the healthcare facility.

### 3.3. System Development techniques and model to be used

#### 3.3.1 Programming

This will achieve by using different software for designing the codes required to develop smart garbage monitoring system.

Then, the next action will be to program ESP 8266 WiFi module as microcontroller and after this will be uploaded into NodeMcu and by connecting the NodeMcu to the USB port through the specific USB cable.

The system environment will be designed using VS codes and Arduino IDE. Then the researcher will continue designing the web application part using languages such as where Html, Laravel PHP framework and its database with MySQLi [23].

#### 3.3.2. Software development model to be used

Applying the Agile model for the development of a smart waste management system for Mugonero District Hospital can be highly effective in ensuring that the project will be completed successfully and meets the hospital's needs . The Agile model is an iterative approach to software development that emphasizes collaboration, flexibility, and continuous improvement see Figure 3.1. It is well suited to complex and dynamic projects, such as the development of an IoT-based system, where requirements may change frequently and unpredictably [25].

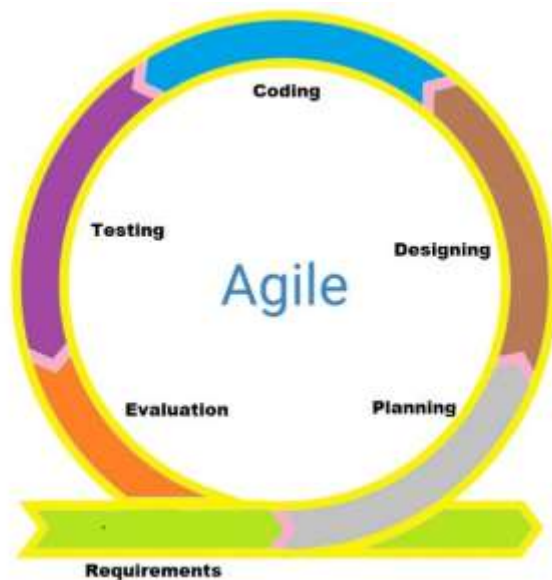

Figure 3.1: Agile model process

The Agile model typically consists of several stages or iterations, each of which involves planning, designing, coding, testing, and evaluating. In the case of a smart waste management system, these stages could include the following:

**Requirements:**In an agile model, requirements gathering and analysis is an ongoing process throughout the project, rather than a separate phase at the beginning. This allows for flexibility and adaptation to changing needs and priorities.

**Planning:** In this stage, the researcher would work with the hospital's stakeholders to define the goals, scope, and requirements for the waste management system. This could involve conducting a needs assessment, identifying key stakeholders, and creating a project plan.

**Designing:** In this stage, the researcher would create a detailed design for the waste management system, including the hardware, software, and communication protocols needed to connect the IoT devices. This could involve creating wireframes, prototypes, and user stories to guide development.

**Coding:** In this stage, the researcher would develop the software and hardware components of the waste management system, using agile coding practices such as pair programming and continuous integration. The code would be tested and reviewed frequently to ensure quality and minimize errors.

**Testing:** In this stage, the researcher would test the waste management system in a variety of scenarios, including real-world conditions, to identify and fix any issues. Testing could involve automated tests, manual tests, and user acceptance testing.

**Evaluation:** In this stage, the researcher would evaluate the performance and effectiveness of the waste management system and identify areas for improvement. This could involve gathering feedback from stakeholders, conducting usability tests, and analyzing system logs.

By this Agile model, the researcher will work closely with the hospital's stakeholders to ensure that the waste management system meets their needs and is delivered on time and within budget. The iterative nature of the Agile model also allows for flexibility and adaptation to changing requirements and priorities, ensuring that the final product is of high quality and meets the hospital's goals.

### 3.3.3. Prototyping model

In developing a circuit integrating NodeMcu, Ultrasonic distance Sensor, Soil Moisture sensor, and infrared technology to facilitate waste type separation, a prototyping and development methodology is crucial. By employing a prototyping and development methodology see Figure 3.2: prototyping model, developers ensure that the smart waste management system meets performance requirements and effectively addresses the waste management needs of Mugonero District Hospital in real-world settings.

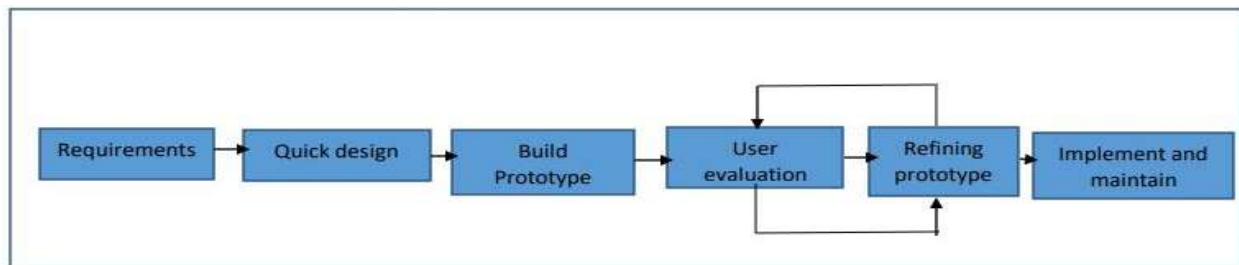

Figure 3.2: prototyping model  
Source: own drawing

### 3.4. The Waste Management Solution for Citizens

The existing waste management system currently utilized in healthcare facilities adheres to an outdated and ineffective model that no longer aligns with the changing needs of the public. This outdated approach heavily relies on large fleets of waste collection that operate on a daily basis, often taking unnecessary routes and adhering to fixed service schedules, regardless of their necessity. These operational inefficiencies not only result in unnecessary waste of valuable time and inflict significant harm on the environment.

This project introduces a comprehensive solution that encompasses both hardware and software components, in addition to integrated communication systems. The goal is to transform the waste management practices at Mugonero District Hospital, promoting environmental sustainability and enhancing staff engagement.

Regarding the research methodology employed, this study adopts a case study approach that involves the real-world implementation of the proposed solution. The developed solution includes a tangible prototype of a smart waste container and a sophisticated waste management

application, interconnected through the IoT middleware. These components are showcased, demonstrated, and subjected to rigorous validation through practical experimentation. The subsequent sections delve into the specifics of this innovative solution.

### **3.4.1. The Waste Management System IoT Architecture Reference Model**

The Waste Management System IoT Architecture Reference Model plays a crucial role in standardizing the IoT segment or vertical. This standardization is pivotal for ensuring the seamless connectivity of these IoT objects, referred to as waste management devices, thereby effectively addressing the challenge of interoperability. When dealing with IoT technology-based applications, the need for a well-defined architecture becomes apparent, especially when considering factors such as scalability, interoperability, reliability, and quality of service (QoS).

In the realm of IoT, there exists a multitude of models and reference architectures, often propagated by various research groups or companies. This diversity can lead to conflicting ideas and complicate the standardization process. Numerous project models revolve around a foundational architecture, typically based on needs analysis or the delineation of specific layers that constitute a fundamental reference architecture model. At its simplest, in Figure 3.3 this approach involves a three-layer architecture comprising the application layer, network layer, and perception layer.

*The Figure 3.3 provides a visual representation of this basic layered architecture within the proposed solution.*

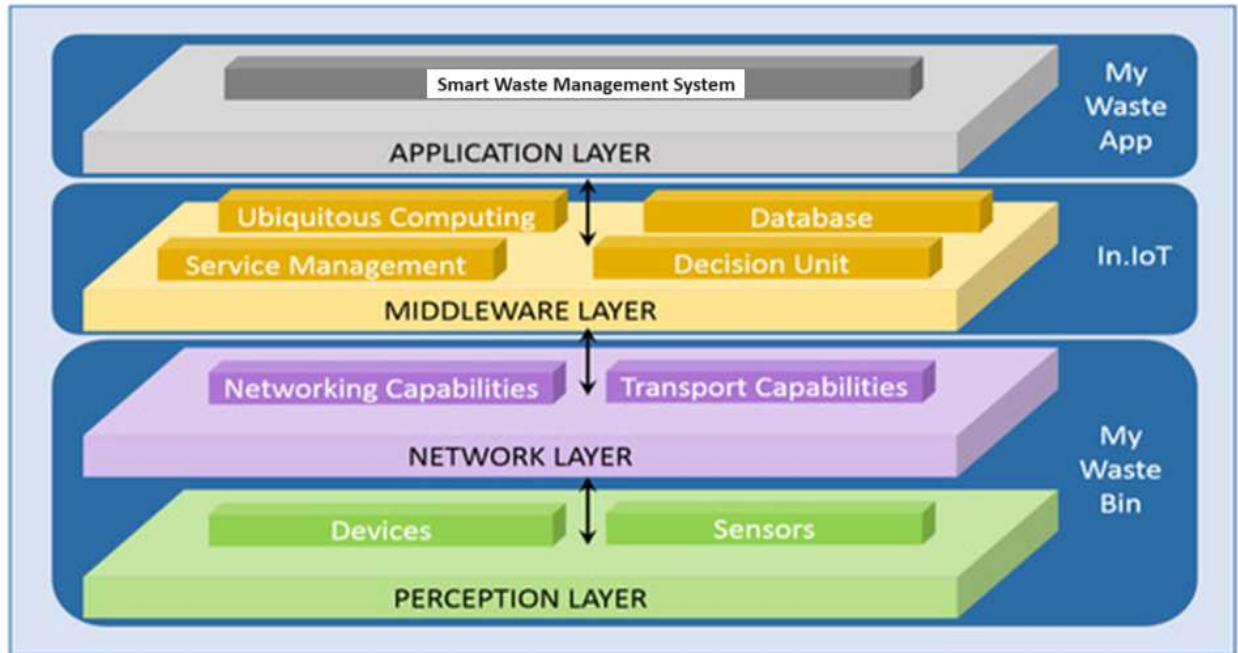

Figure 3.3:basic layered architecture

Source: Own drawing

These layers follow a cyclic pattern as outlined in the proposed model.

**Perception Layer:** In the IoT architecture, the perception layer closely resembles the physical layer of the Open Systems Interconnection (OSI) model. It operates at the hardware level and is responsible for gathering physical data, processing it, and securely transmitting it to the higher layers. This layer utilizes technologies for detecting various physical parameters, such as weight, temperature, humidity, and more. Additionally, it collects data related to object identification, including quick response codes (QR codes) and RFID tags.

**Network Layer:** The network layer plays a crucial role in transporting the data acquired in the perception layer to the upper layers, where processing systems are situated. It employs various communication technologies such as Wi-Fi, Infrared to facilitate data transfer beyond basic data transmission.

**Middleware Layer:** Positioned between hardware and software components, the middleware layer acts as a bridge or interpreter within the IoT ecosystem. It connects components that might not otherwise communicate effectively. Apart from enabling smooth interaction between the

application layer and the perception layer, it also contributes significantly to the development of new technologies.

***Application Layer:*** While not directly involved in constructing the IoT architecture, the application layer serves as the interface where various services are built to interact with users. This layer is where information is interpreted and made available for user access and utilization.

### **3.4.2. Architecture of My Waste Management System**

#### **3.4.2.1:Key terms**

##### **1. System**

It is an arrangement of parts or elements that serve the same function. Sometimes the word refers to the organization, while other times it refers to system components (as in cooperative). A system is a collection of interconnected or interdependent elements presented in a way that is understandable by humans, frequently with the goal of exposing design.

##### **2. Database**

Any collection of data or information that has been properly structured for quick search and retrieval by a computer is referred to as a database, often known as an electronic database.

##### **3. Data**

The quantities, characters, or symbols that computers use to accomplish operations; these values, characters, or symbols may be recorded on magnetic, optical, or mechanical recording media or stored and transferred as electrical signals.

##### **4. Web browser**

A web browser, sometimes known as a browser, is a piece of software used to access content on the World Wide Web. The web browser obtains the necessary information from a web server and displays the page on the user's device when a user requests a web page from a certain website.

##### **5. Web server**

Here, the term "web server" can refer to either software or hardware (a computer) that aids in the delivery of freely accessible content through the browser. By taking requests from the user's browser and responding by sending back HTML documents (Web pages) and files, it offers the web application capabilities.

### 3.4.2.2 Some hardware tools used

#### 1. Ultrasonic Sensor

The ultrasonic sensor is activated to use ultrasonic waves to measure the distance between itself and the obstruction see Figure 3.4. The ultrasonic sensor's head sends out an ultrasonic wave, which is then returned to it by the item. The distance to the target is then estimated using the formula:

$$\text{distance} = (\text{duration} * 0.0343) / 2;$$

$$\text{used} = \text{binHeight} - \text{distance};$$

$$\text{percentage} = (\text{used} / \text{binHeight}) * 100;$$

after monitoring the amount of time between the ultrasonic wave's emission and receipt.



Figure 3.4: ultrasonic distance sensor

Source: internet

#### 2. Capacitive Soil Moisture

The Capacitive Soil Moisture Sensor refer Figure 3.4 is primarily designed for measuring the volumetric water content of soil. However, its application extends beyond just soil moisture monitoring. In recent times, researchers and innovators have explored its use in waste type detection, particularly in the realm of smart waste management systems.

By utilizing the sensor's capacitive properties, it becomes possible to detect variations in the dielectric constant of materials. Different types of waste, such as organic waste, plastics, metals, and paper, exhibit varying dielectric constants. When waste is in contact with the sensor, it alters the capacitance of the system, creating a distinguishable signature for different waste types.



Figure 3.5: Capacitive Soil Moisture Sensor

Source : internet

### 3. *Servo Motor*

A servo motor refer to Figure 3.6 the figure is used component in smart dustbins that incorporate waste type detection. After the waste type is identified, the servo motor is responsible for controlling the movement of different compartments or sections within the dustbin to facilitate proper waste segregation.

When waste is detected and classified by the system, the control circuit sends signals to the servo motor based on the waste type. The servo motor then adjusts the position of the compartments or sections within the dustbin accordingly. This movement allows for the separation and allocation of different types of waste into designated compartments, ensuring effective waste segregation.

By incorporating a servo motor into the smart dustbin's waste type detection system, the process of waste segregation becomes more efficient and reliable. It enables the dustbin to effectively organize and separate different types of waste, contributing to improved recycling efforts and reducing environmental impact.

The servo motor plays a crucial role in smart dustbins with waste type detection by providing precise control over the movement of compartments or sections. This allows for accurate waste segregation and contributes to more effective and sustainable waste management practices.



Figure 3.6: Servo Motor

Source: internet

### 4. *NodeMcu*

Espressif Systems makes the NodeMcu, an open-source Wi-Fi system on chip. It is an integrated chip that gives the embedded circuit in which it is located full internet connectivity. The Arduino IDE can be used to program it through a USB port.

It uses a small amount of power. It has been used as the primary microcontroller in this project because it includes built-in Wi-Fi connectivity, which can be used to provide real-time monitored sensor data to web applications see Figure 3.7.



Figure 3.7:Nodemcu(esp8266)  
Source: internet

### 5. *Printed Circuit Board (PCB)*

Copper tracks rather than wires are used to connect electrical components on a printed circuit board, or PCB see Figure 3.8. Drilled holes are used to fix electrical components in place on the board. The copper tracks connect them to one another to form a circuit once they are soldered into place to solidify their location.

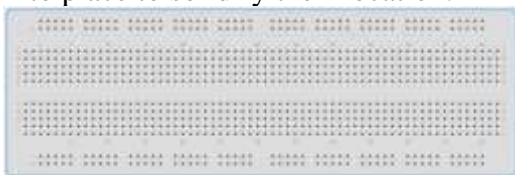

Figure 3.8:printed circuit board  
Source: internet

### 6. *USB*

The connector for the universal serial bus (USB). In order to power the board, upload your instructions to the Microcontroller, and send and receive data from a computer, this links the board to your computer see Figure 3.9.



Figure 3.9:universal serial connector  
Source: internet

### 7.*Arduino Uno*

The Figure 3.10 is the Arduino Uno which is defined as a compact and versatile microcontroller board. It is a popular choice for IoT projects due to its small size, low cost, and ease of use. It is programmed using the Arduino IDE and is compatible with a wide range of sensors and modules.

As our project Smart waste Management system in Mugonero District Hospital is based on IoT technology, it requires the integration of sensors, microcontrollers, and communication modules to monitor and manage waste bins more efficiently and help in ensuring timely waste collection, optimizing resources, and contributing to a cleaner and more efficient waste management process.



Figure 3.10:Arduino Uno  
Source: internet

### **3.5 Smart waste monitoring and clearance system using internet of things**

This system illustrates the level of waste in the dustbins is detected with the help of Ultrasonic sensor. When the measured level of sensors exceeds a certain level, this information within the dust bin will be send to the server and Microcontroller is used to interface the sensor system.

One of the significant device-based project ideas is the ESP8266 which was first configured by flashing the most recent firmware, which was the first step in the implementation. The Blynk libraries can communicate effectively as a result[24]. They obtained the ESP8266 flasher tool and the most recent firmware, which would be in bin format, from the internet and used it to flash the ESP8266. Other parts were added to the setup when the ESP8266 flashing was complete. The microcontroller, ultrasonic sensor, infrared, motor, and ESP8266 were all connected with jumper wires using a breadboard. The various components available were interfaced using a breadboard. In Figure 3.11 displays the several connected inputs to a single Arduino pin and was also helpful[24].

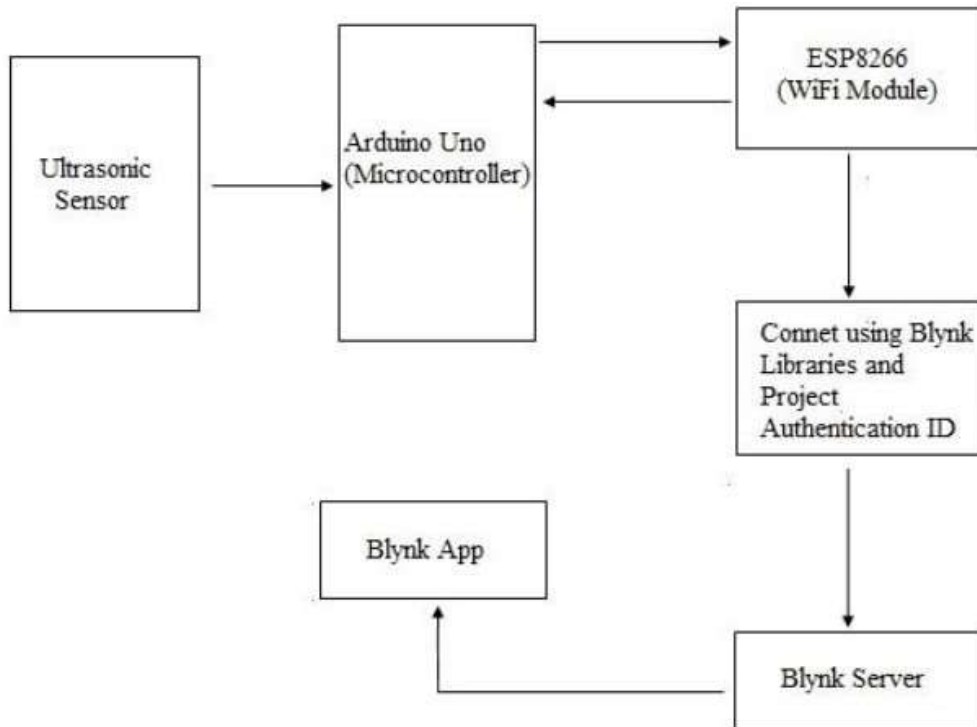

Figure 3.11:architecture diagram of garbage monitoring using iot  
Source: own drawing

## **Chapter 4.SYSTEM ANALYSIS AND DESIGN**

### **4.1. System Analysis**

System analysis is the process of analyzing the existing system in order to propose the new improved system for the hospital. SA is more like a consulting process to propose the best solution to the organization by means of variety of methods and technologies[25].

#### **4.1.1. System requirement**

To develop this System “**Smart Waste Management System**” the researcher used different tools in developing my system as mentioned above, many resources were needed:

##### **➤ Software requirements**

- ❖ Arduino IDE
- ❖ XAMPP (Mysql, apache server) for the conception of the graphic interface allowing the users to interact.
- ❖ Mysql for the creation of the database
- ❖ Operating system: Microsoft Windows10, etc...
- ❖ Browser: Mozilla Firefox, Google chrome, etc....
- ❖ Web server: Apache service
- ❖ Front End tools: HTML, Sublime text, Edit plus or notepad, dream weaver etc...

##### **➤ Hardware requirements**

- ❖ Personal computer
- ❖ Small plastic container
- ❖ Arduino Uno
- ❖ Ultrasonic Sensor
- ❖ NodeMCU
- ❖ LED
- ❖ Jumper wires
- ❖ Breadboard
- ❖ Power supply
- ❖ Basket

### **4.1.2 Current system**

The manual system was all about going every in different observing in different places where waste is thrown without even knowing even the type of waste or if the dustbins are full which sometimes consumes time by looking if the bins are full or not.

### **4.1.3 Proposed system**

My proposed system “**SMART WASTE MANAGEMENT SYSTEM**” which makes the normal dustbin as smart bin. This monitoring system is equipped with ultrasonic sensor; NodeMCU and are interfaced with Arduino. Here garbage levels are monitored and up-dating the status of the bin in MySQL database and then level displayed on Dashboard through NodeMCU ESP8266 Wi-Fi Module. Where the dustbins will be cleaned according due to time on which they are full.

In ‘Real time wastes management system’ the level out of wastes in the bins are detected beside the aid of sensors and sensed data is transmitted in MySQL database and then level of wastes appears on Dashboard employing Arduino Uno which is having in-built Wi-Fi module (ESP8266)[26]. When the bins are full of waste the system alerts the collector via email and /or sms.

### **4.1.4 System Hardware design**

The bin comprises sensors nodes and gateway nodes. Each bin is equipped with sensors node powered by a battery. These sensor nodes detect the type of waste, bin fullness, provide readings and reports the bin status. Bin capacity is determined using ultrasound sensors. Upon receiving sensor readings, the system initiates appropriate actions. Data is transmitted to the gateway node through low-power radio in the 2.4 GHz band[27]. Each sensor cluster contains a gateway node, which caters to the sensors within its cluster. The type of waste is scanned and sensors determine wither is dry waste or wait and disposed in appropriate bin see Figure 4.1. The waste level is calculated based on the indoor coverage range sensors. When the gateway node receives data from the sensor nodes, it relays this information to the backend server via any available internet connection, such as Ethernet, WiFi, ,3G or 4G[28].

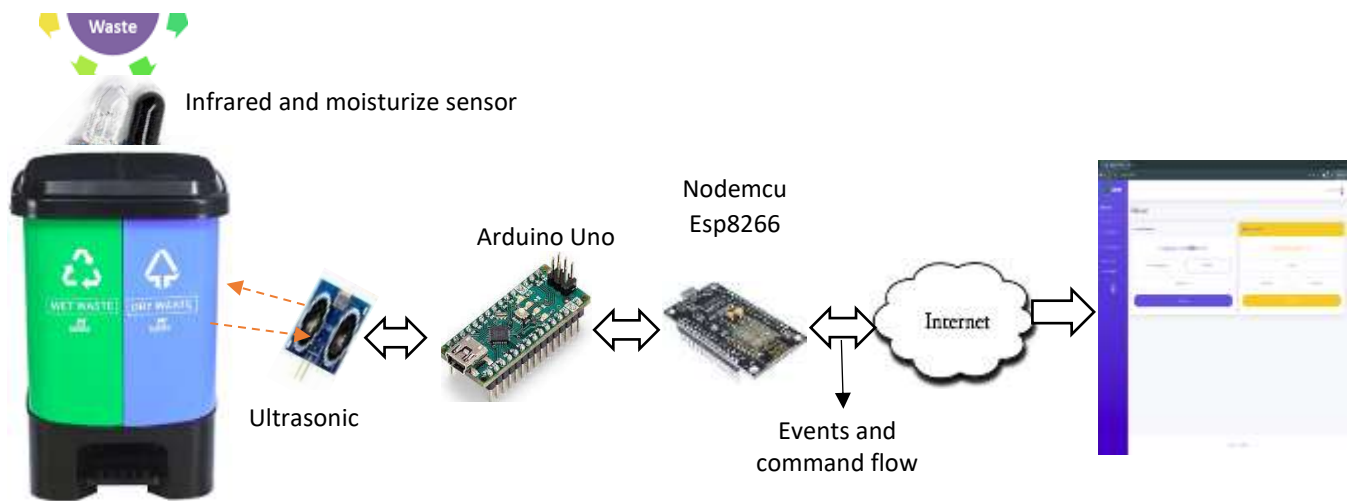

Figure 4.1: System hardware design  
Source: own drawing

## 4.2. System Design

The Smart Waste Management System implemented at Mugonero District Hospital leverages IoT (Internet of Things) technology to efficiently manage waste collection and enhance environmental sustainability. This system optimizes the waste collection process, monitors bin fill levels, and ensures timely waste collection, contributing to a cleaner and healthier hospital environment[29].

### 4.2.1 User interface:

#### 1. User login

Refer to the Figure 4.2 the User Login System for the Smart Waste Management System at Mugonero District Hospital is a secure and efficient access control mechanism designed to manage user interactions with the hospital's IoT-based waste management system. This system ensures that authorized personnel can log in, access relevant features, and monitor the waste disposal process effectively.

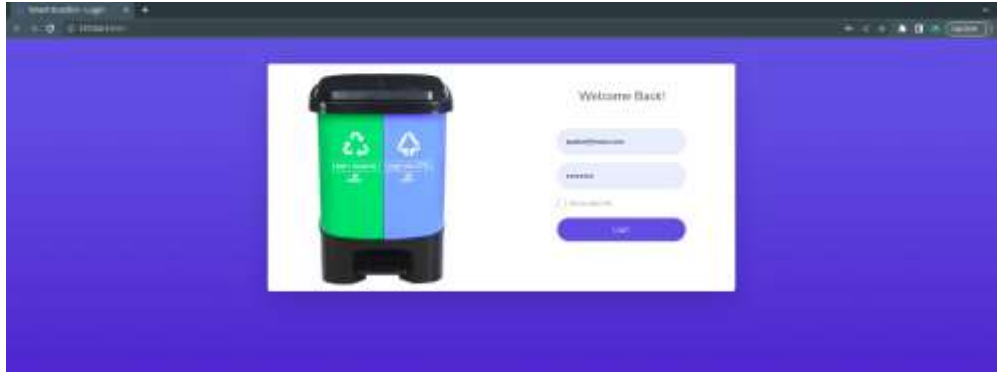

Figure 4.2: System user login interface  
Source: extracted from system

**2.Admin system dashboard**

The Smart Waste Management System employs a network of IoT sensors placed in various locations within Mugonero District Hospital. These sensors monitor waste bin capacities, waste types, and collection schedules. The data collected by these sensors is transmitted to the central admin dashboard, allowing administrators to make informed decisions and streamline waste management operations see Figure 4.3.

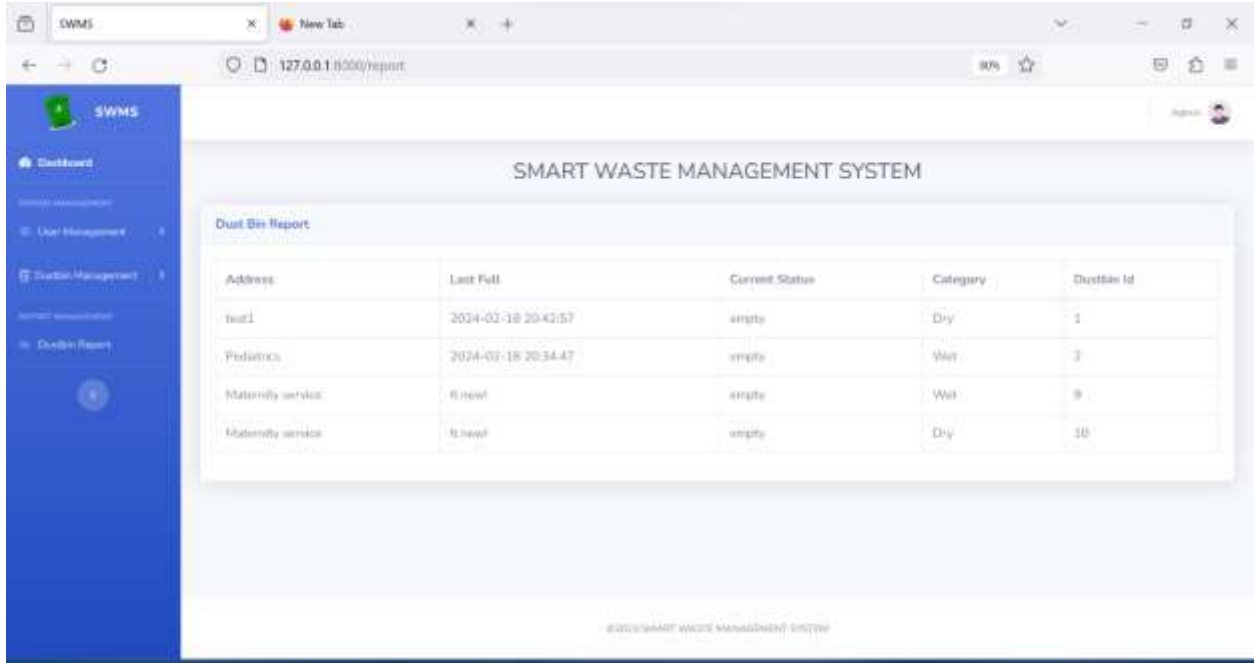

Figure 4.3: Admin system dashboard  
Source: extracted from system

### 4.2.2 Functional Diagram

A Functional Diagram for a Smart Waste Management System using IoT in Mugonero District Hospital illustrates the essential functions and interactions of the system components. In this context, the diagrams would detail how various elements, such as sensors, data transmission devices, and backend servers, work together to efficiently manage hospital waste[30].

It showcases the interconnected elements of the system. At its core are smart sensors installed in waste bins throughout the hospital premises. These sensors employ IoT technology to monitor the fill levels and other parameters of the bins in real-time.

When waste bins reach a certain threshold, the sensors send signals to data transmission devices, often using low-power radio frequencies or other wireless communication protocols. These devices then relay the information to a central gateway or server within the hospital premises.

The central server processes the incoming data, analyzing the fill levels and other relevant metrics. Based on this analysis, the system triggers notifications to the hospital staff, indicating which bins need to be unfilled. This proactive approach ensures timely waste collection and minimizes the risk of overflowing bins, maintaining hygiene and safety standards within the hospital environment.

Hospital administrators can access real-time reports, historical data, and analytics through a user-friendly dashboard. This integration enhances the overall efficiency and management capabilities of the waste disposal process as described in the Figure 4.4.

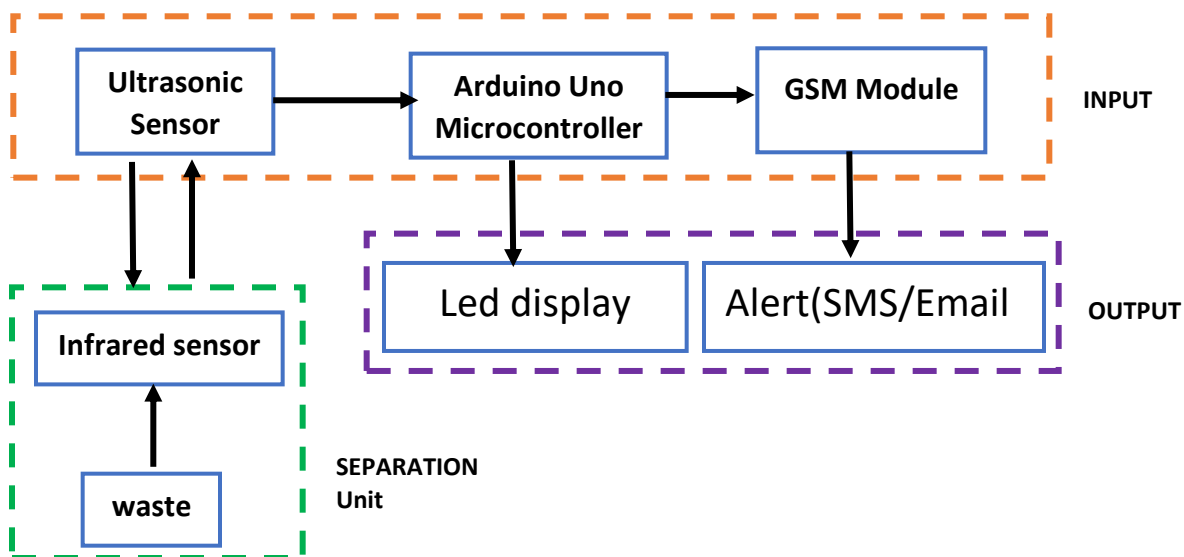

Figure 4.4: System Functional Diagram

### 4.2.3 Use Case Diagram

A Use Case Diagram for the Smart Waste Management System at Mugonero District Hospital outlines the various interactions and functionalities within the system see Figure 4.5. In this context, hospital staff, waste bins, sensors, and the central server are the primary actors. The diagram illustrates the essential actions, depicting how these actors interact with the system.

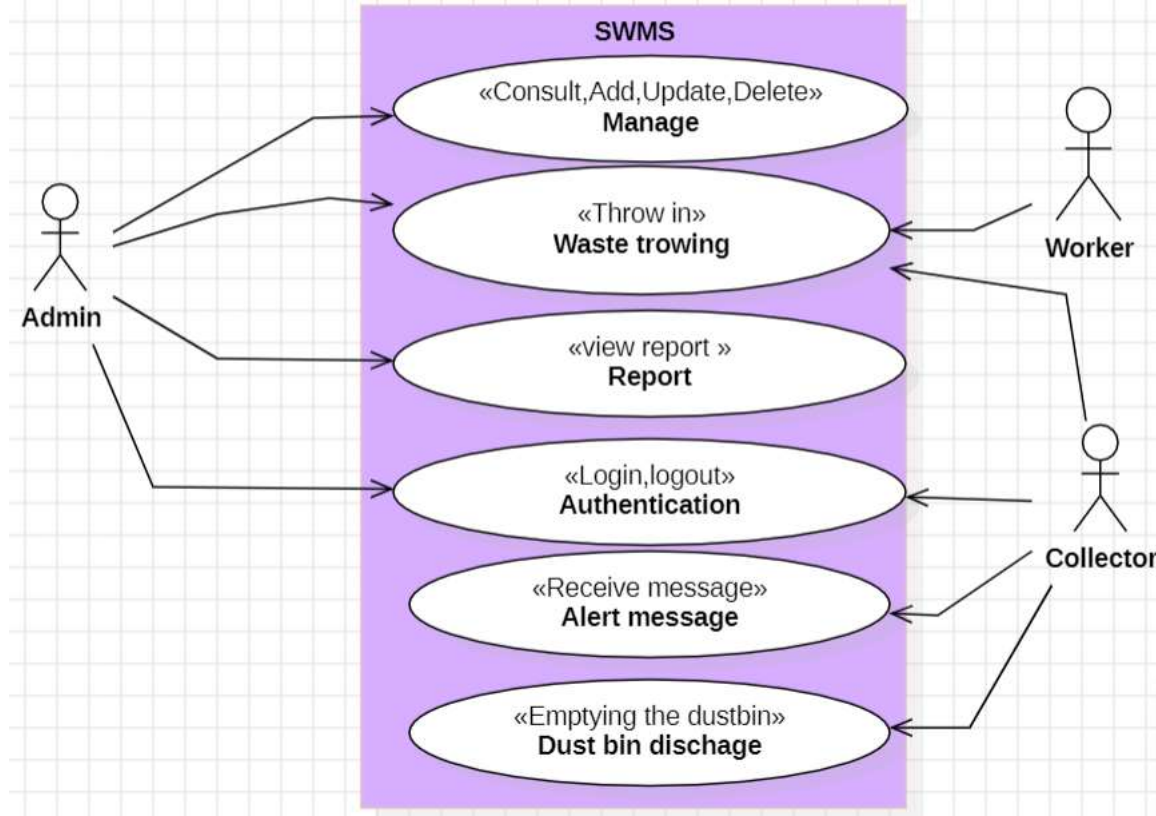

Figure 4.5:system User case Diagram

### 4.2.4 Entity Relationship Diagram(ERD)

In Figure 4.6 the following ERD is for the Smart Waste Management System to implement at Mugonero District Hospital, Smart bins are represented as primary entities. These Smartbins are equipped with Sensor Nodes that monitor waste types, levels and statuses. Sensor Nodes communicate this data to Gateway Nodes, creating a one-to-many relationship, where one Gateway Node can serve multiple Sensor Nodes. Hospital Staff members have a relationship with Smartbins as they interact with them for waste disposal. Waste Collection also form a part of the system, collecting waste from Smart bins based on the data received. All these entities are interconnected through various relationships, ensuring efficient waste management within the hospital premises.

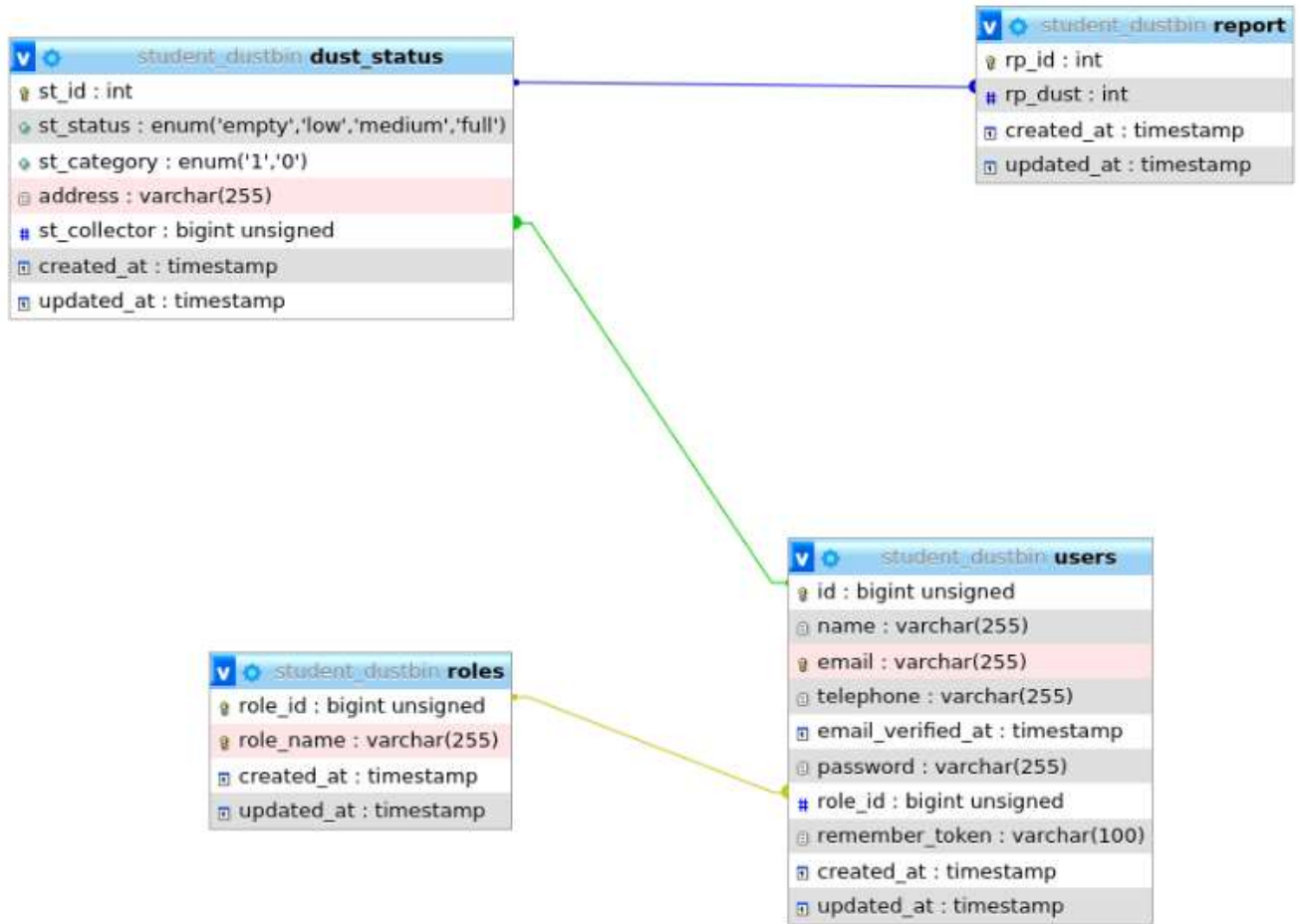

Figure 4.6:ERD system diagram

### 4.2.5 Flow Chart Diagram

It is a schematic representation of algorithm or process. It has the purpose of to develop the logical system, Documentation for a system, provides means of communication with other about the system.

The provided flow chart in Figure 4.7 illustrates the operational concept of our project. The design is divided into two modules: the first module focuses on sensing and monitoring garbage levels, while the second module analyses the local database to store the sensed data. It then displays the waste levels in the smartbin on the dashboard.

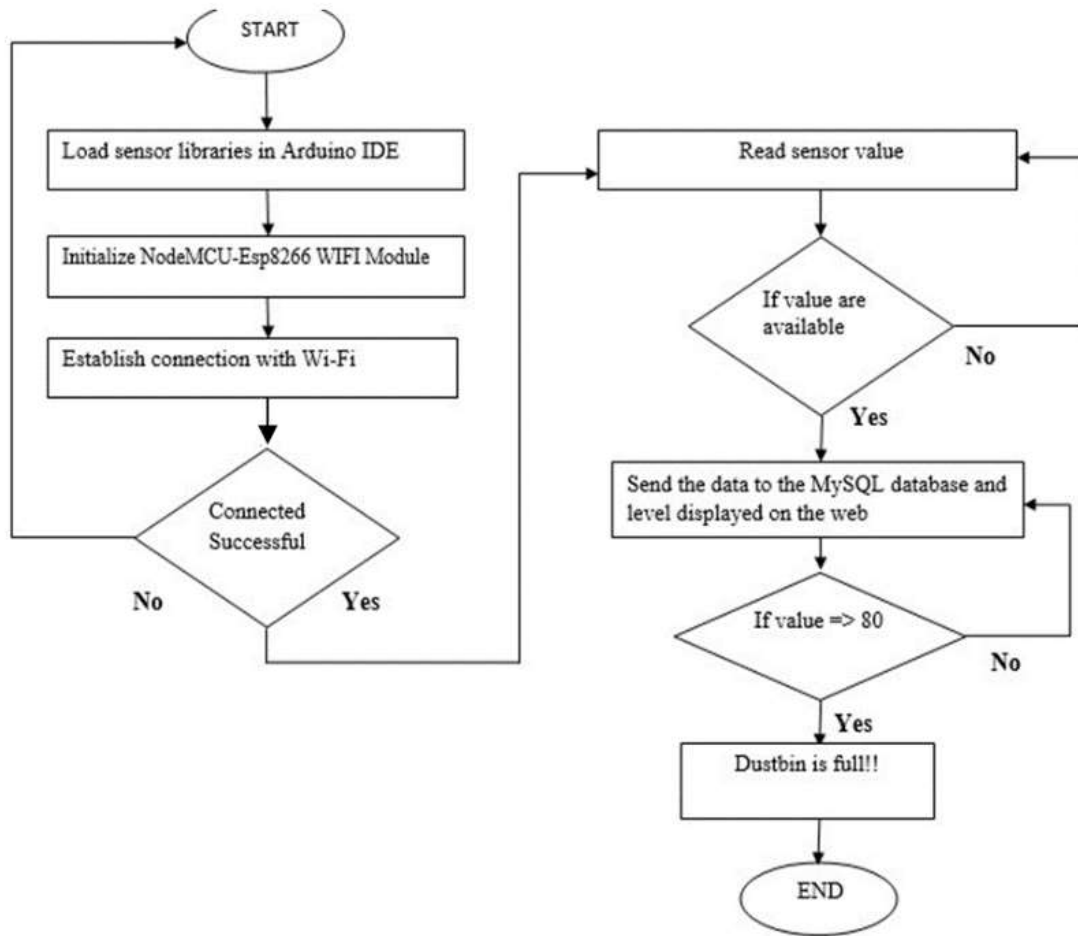

Figure 4.7:Flowchart system Diagram

### 4.3 Data Dictionary

The Data Dictionary for the Smart Waste Management System implemented through IoT technology in Mugonero District Hospital serves as a comprehensive reference guide detailing the structure and meaning of the data used within the system. In this context, the system is designed to enhance waste management processes in the hospital by integrating IoT devices, allowing for efficient and real-time monitoring of waste levels in Smartbins.

Some **examples** of what might be contained in an organization's **data dictionary** include: The names of fields contained in all of the organization's databases see Figure 4.8, Figure 4.9, Figure 4.10, and Figure 4.11.

## roles

Column	Type	Null	Default	Links to	Comments	Media type
role_id ( <i>Primary</i> )	bigint	No				
role_name	varchar(255)	No				
created_at	timestamp	No	CURRENT_TIMESTAMP			
updated_at	timestamp	No	CURRENT_TIMESTAMP			

Figure 4.8:system User Roles

## users

Column	Type	Null	Default	Links to	Comments	Media type
id ( <i>Primary</i> )	bigint	No				
name	varchar(255)	No				
email	varchar(255)	No				
telephone	varchar(255)	No				
email_verified_at	timestamp	Yes	NULL			
password	varchar(255)	No				
role_id	bigint	No		roles -> role_id		
remember_token	varchar(100)	Yes	NULL			
created_at	timestamp	No	CURRENT_TIMESTAMP			
updated_at	timestamp	No	CURRENT_TIMESTAMP			

Figure 4.9:User identification

## dust\_status

Column	Type	Null	Default	Links to	Comments	Media type
st_id ( <i>Primary</i> )	int	No				
st_status	enum('empty', 'low', 'medium', 'full')	No				
st_category	enum('1', '0')	No				
address	varchar(255)	No				
st_collector	bigint	No		users -> id		
created_at	timestamp	No	CURRENT_TIMESTAMP			
updated_at	timestamp	No	CURRENT_TIMESTAMP			

Figure 4.10:Dust Status

Column	Type	Null	Default	Links to	Comments	Media type
rp_id (Primary)	int	No				
rp_dust	int	No		dust_status -> st_id		
created_at	timestamp	No	CURRENT_TIMESTAMP			
updated_at	timestamp	No	CURRENT_TIMESTAMP			

Figure 4.11:Dustbin report

#### 4.4. Class Diagram

This class diagram represents the static structure of the Smart Waste Management System, detailing the classes involved, their attributes and methods, relationships between classes, and the organization of the system into packages see Figure 4.12. It's important to note that this is a simplified example, and the actual implementation might involve more details and additional classes depending on the specific requirements and functionalities of the system in Mugonero District Hospital.

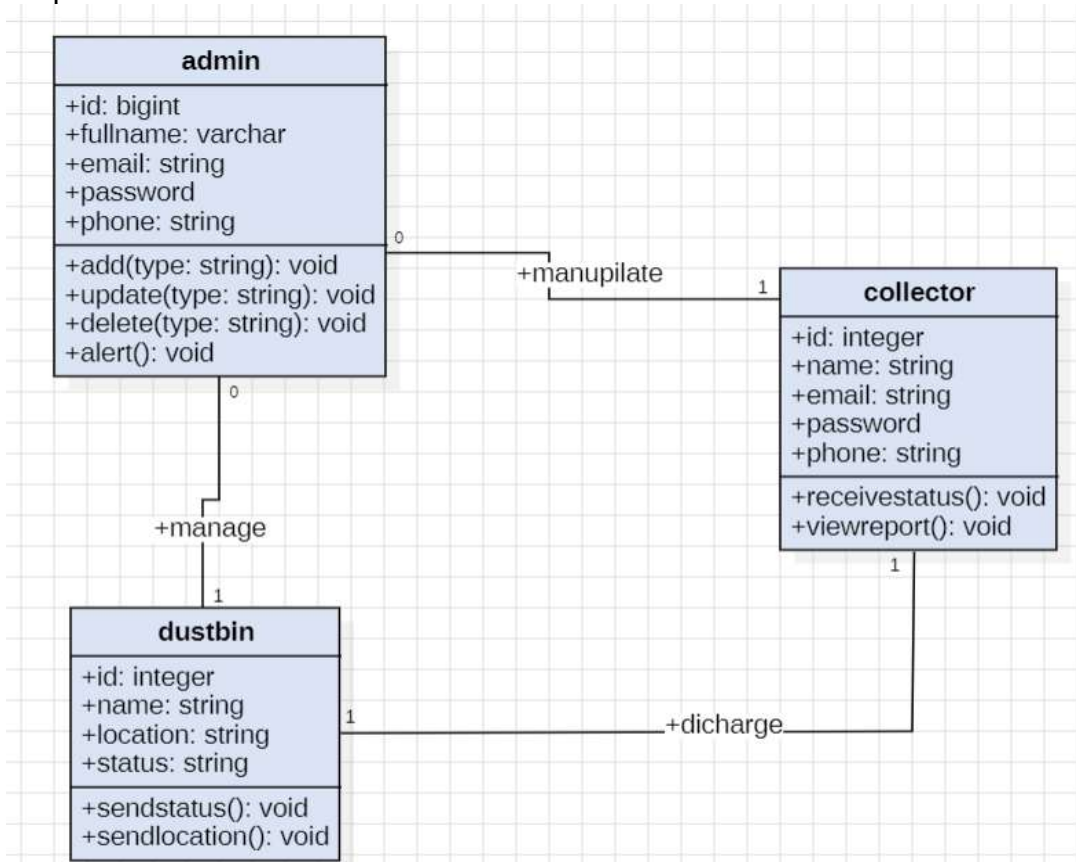

Figure 4.12: System class diagram

## 4.5. Activity diagram

An activity diagram is a type of UML diagram that illustrates the flow of activities within a system. In the context of a smart waste management system using IoT at Mugonero District Hospital, an activity diagram can depict the various actions and interactions between different components such as the system, dustbins, and trash collection. In Figure 4.13 is a textual description of the activity diagram: Start, System Initialization, Read Sensor Data, Check Fill Level, Generate Alert, Send Notification, Update System Status, Empty Dustbin, Update Fill Level, End.

This activity diagram illustrates the dynamic flow of activities in the smart waste management system, emphasizing the interaction between the system, dustbins, and the trash collection process at Mugonero District Hospital.

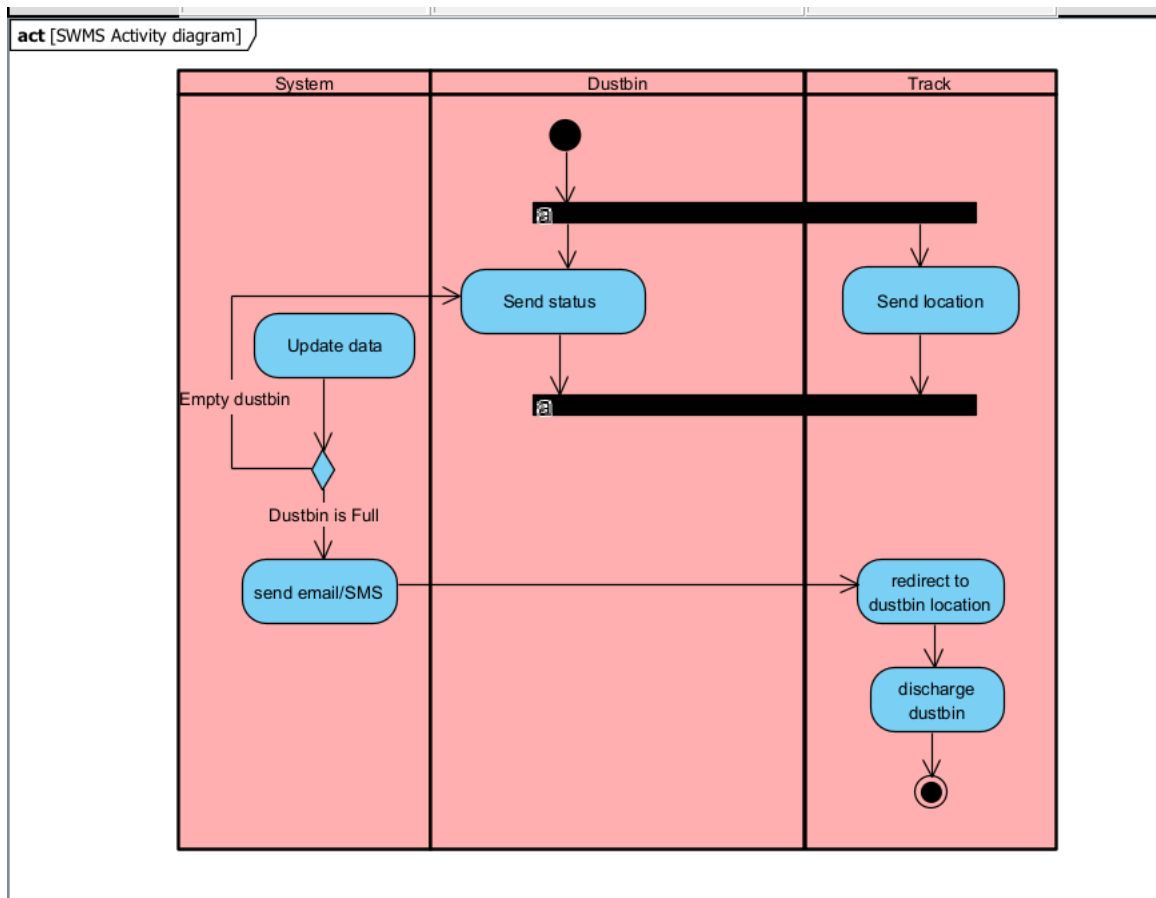

Figure 4.13: Activity diagram

## **Chapter 5.RESULTS AND ANALYSIS**

In this chapter, we present the results and analysis of the Smart Waste Management System based on the Internet of Things (IoT) implemented in Mugonero District Hospital. This advanced system integrates IoT technology to enhance waste management efficiency, environmental sustainability, and overall hospital hygiene. The chapter provides a comprehensive analysis of the collected data, assessing the system's performance and impact on waste management practices[31].

### **5.1. Introduction to the System:**

The Smart Waste Management System based on IoT aims to revolutionize waste management practices in Mugonero District Hospital. By leveraging IoT sensors, real-time data analytics, and automated processes[32], the system optimizes waste collection, reduces contamination risks, and ensures compliance with environmental regulations[32].

#### **5.1.1: System users' registration:**

In this section we delve into the results and analysis of the System Users Registration process for the Smart Waste Management System implemented in Mugonero District Hospital. This crucial aspect of the system focuses on onboarding and registering hospital staff, administrators, and other stakeholders into the IoT-based platform, ensuring effective utilization of the waste management system[33]. The detailed examination of the registration data, assessing the efficiency of the process and its impact on the overall functionality of the Smart Waste Management System[34].

##### **5.1.1.1. User Registration Process Efficiency:**

The registration process was meticulously designed to be user-friendly and efficient refer to the Figure 5.1. Data analysis indicates a seamless registration experience. The system's intuitive interface and clear instructions facilitated swift user onboarding, ensuring minimal disruptions to daily hospital operations[35].

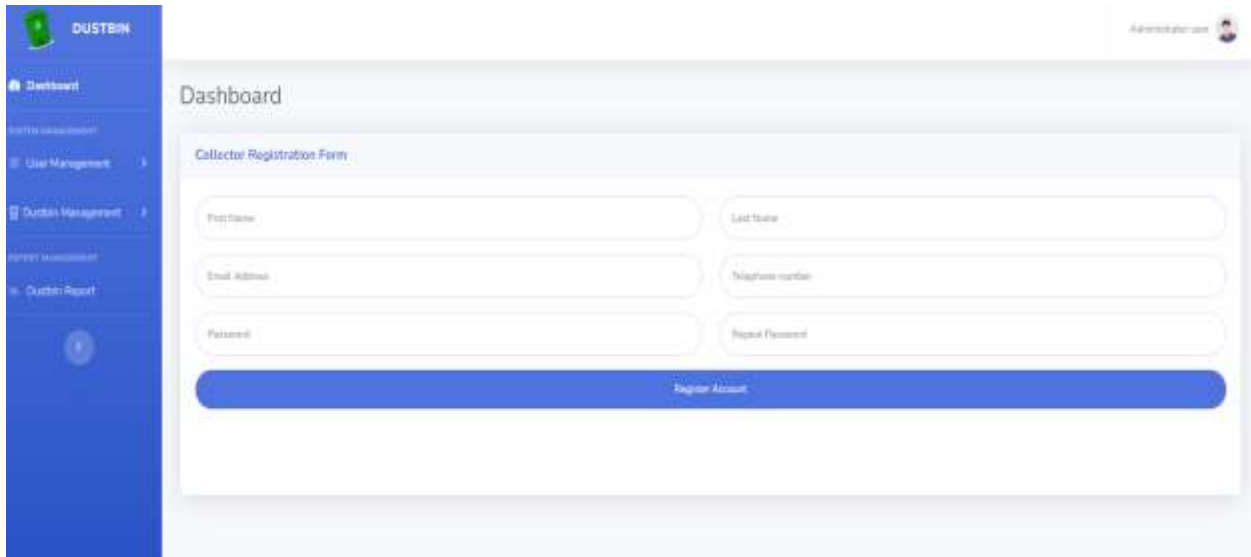

Figure 5.1: System User registration form

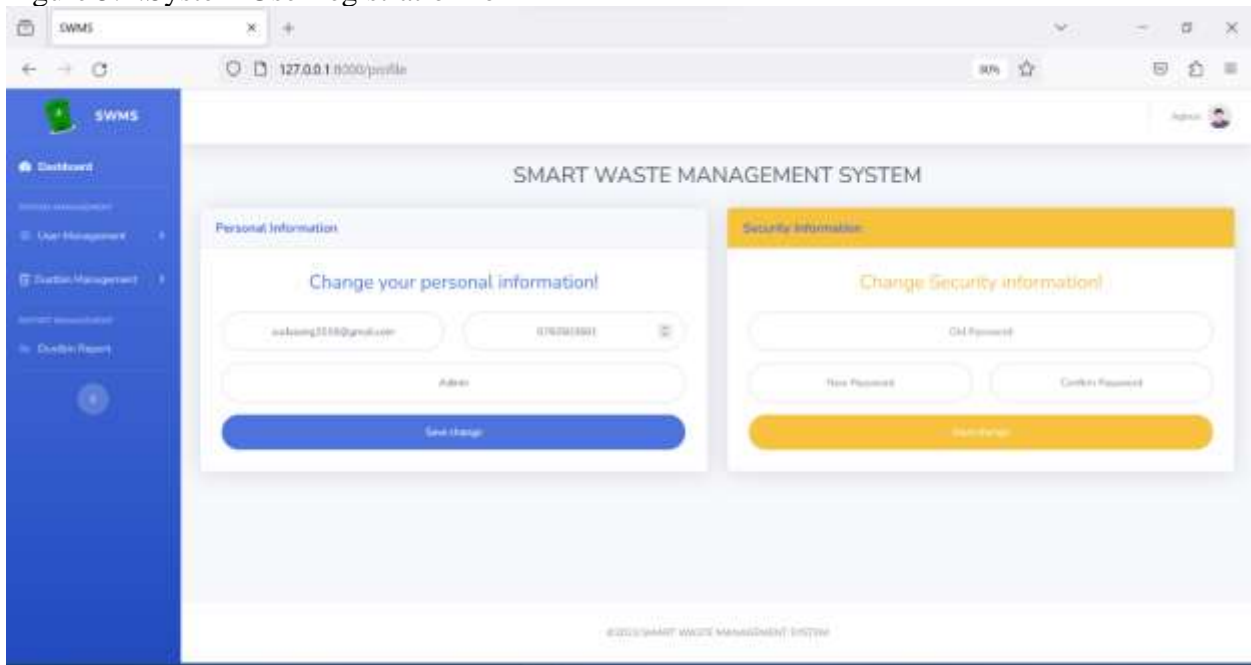

Figure 5.2: System user personal information page

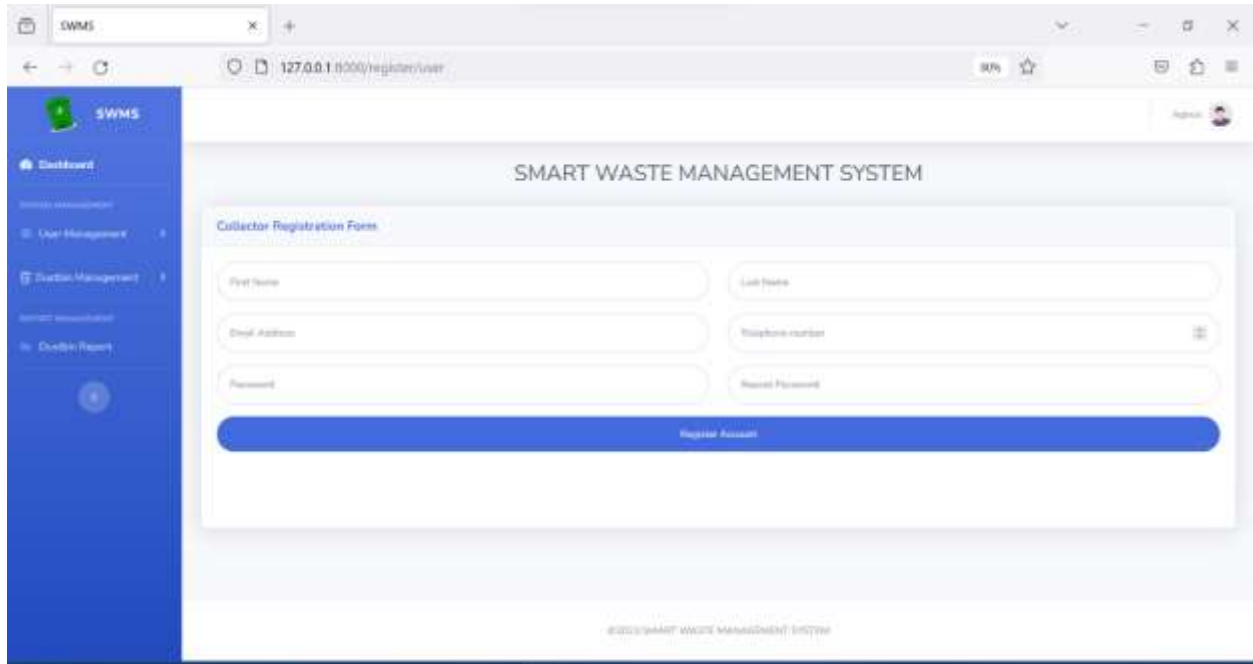

Figure 5.3: System collector registration form

### **5.2. User Demographics and Roles:**

Analysis of the registered users' demographics reveals a diverse user base. The system successfully system users such as administrator and collectors. Understanding the demographics allows for tailored system utilization, catering to the specific needs and responsibilities of different user groups within the hospital[36].

### **5.3. System Access and Permissions:**

Data analysis revealed that the system effectively managed user access and permissions. Role-based access control ensured that each user had appropriate privileges aligned with their responsibilities[37]. For instance, in the Figure 5.4, healthcare providers had access to real-time waste level data, enabling them to make informed decisions. This precise access control mechanism ensured the system's security and data integrity[38].

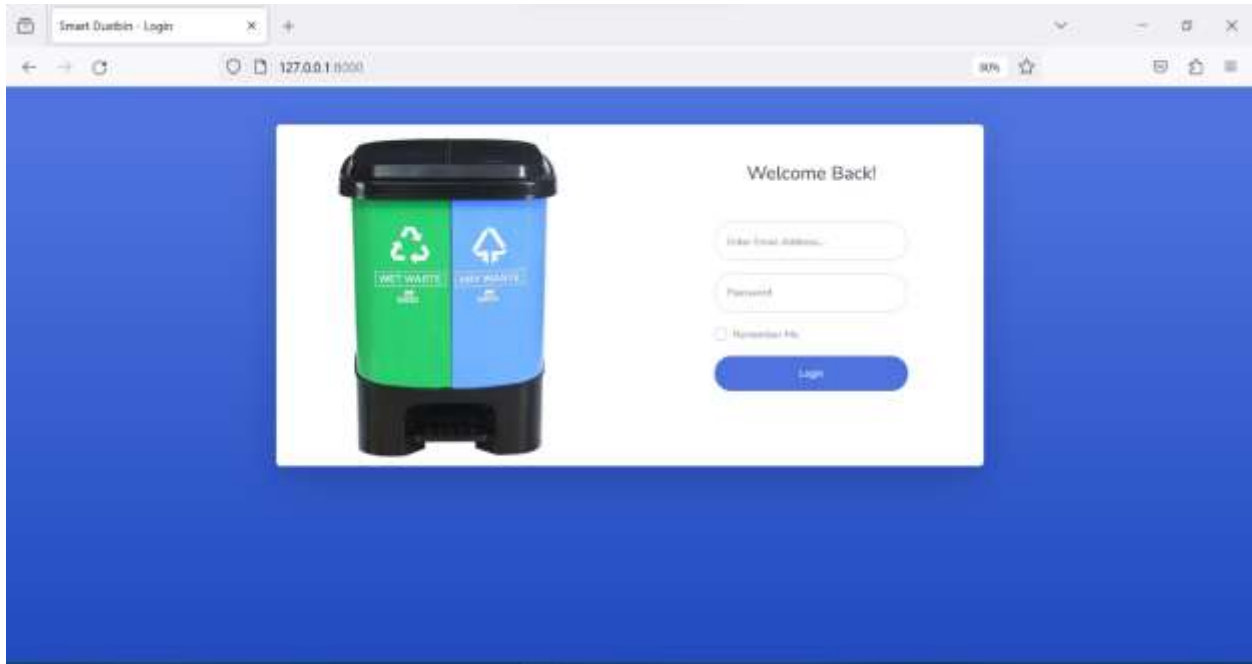

Figure 5.4: System user credentials login

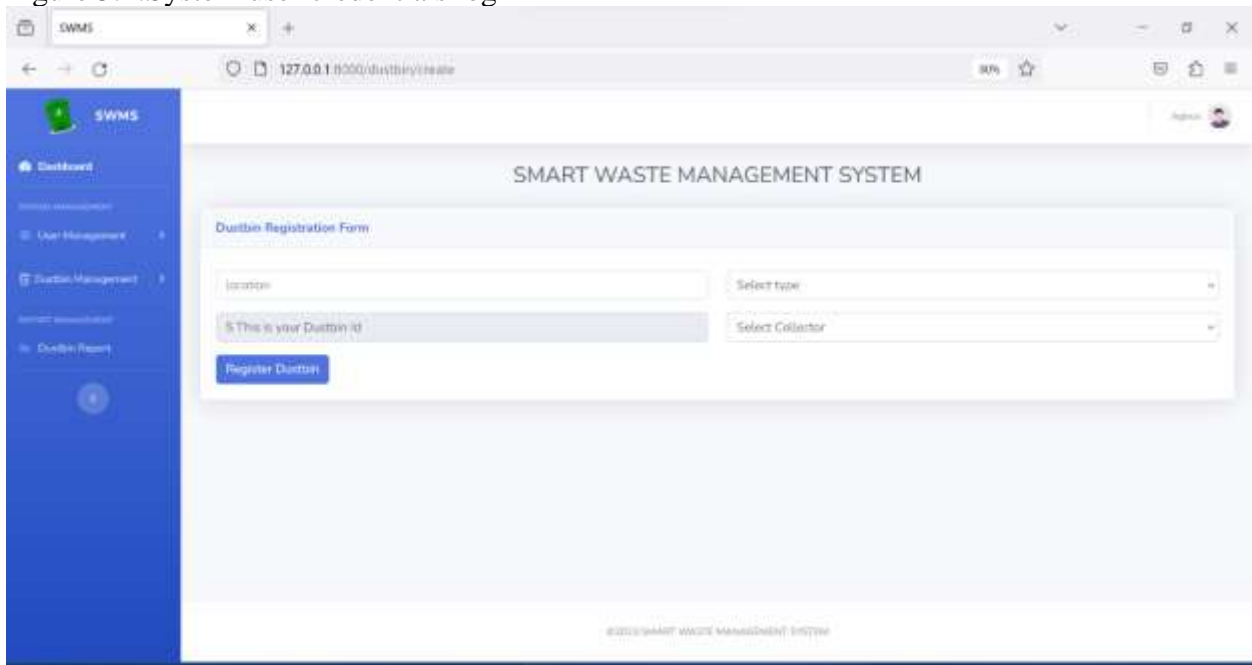

Figure 5.5: Dust bin creation form

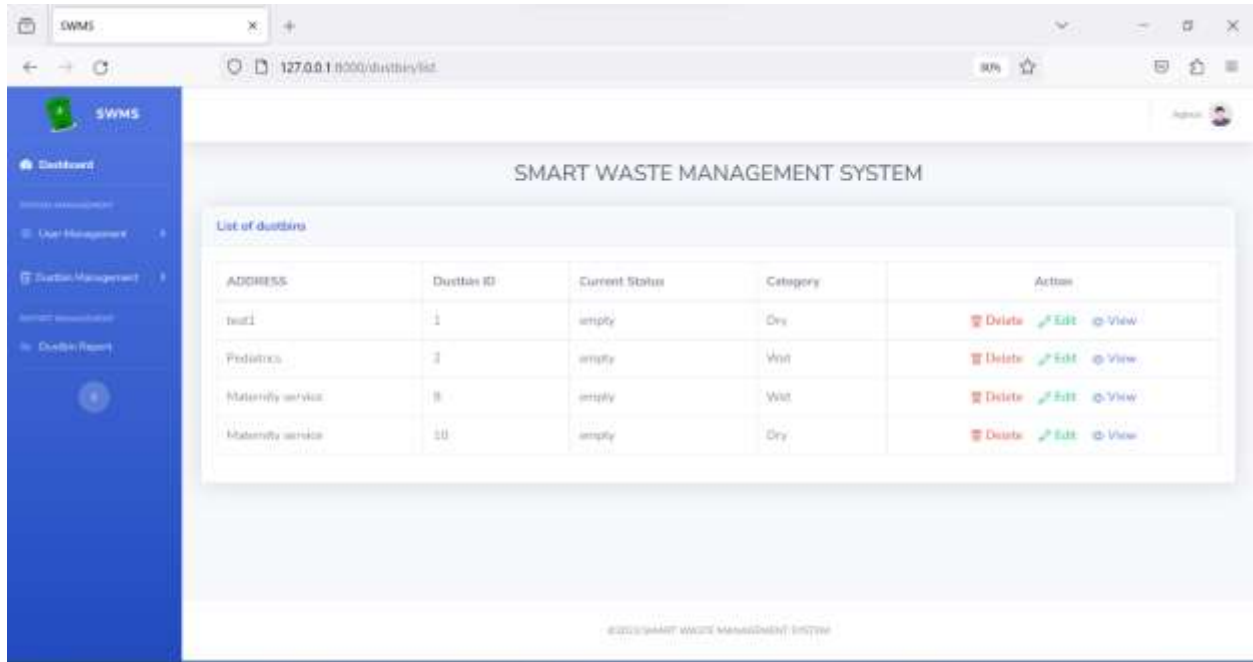

Figure 5.6:List of registered dustbins

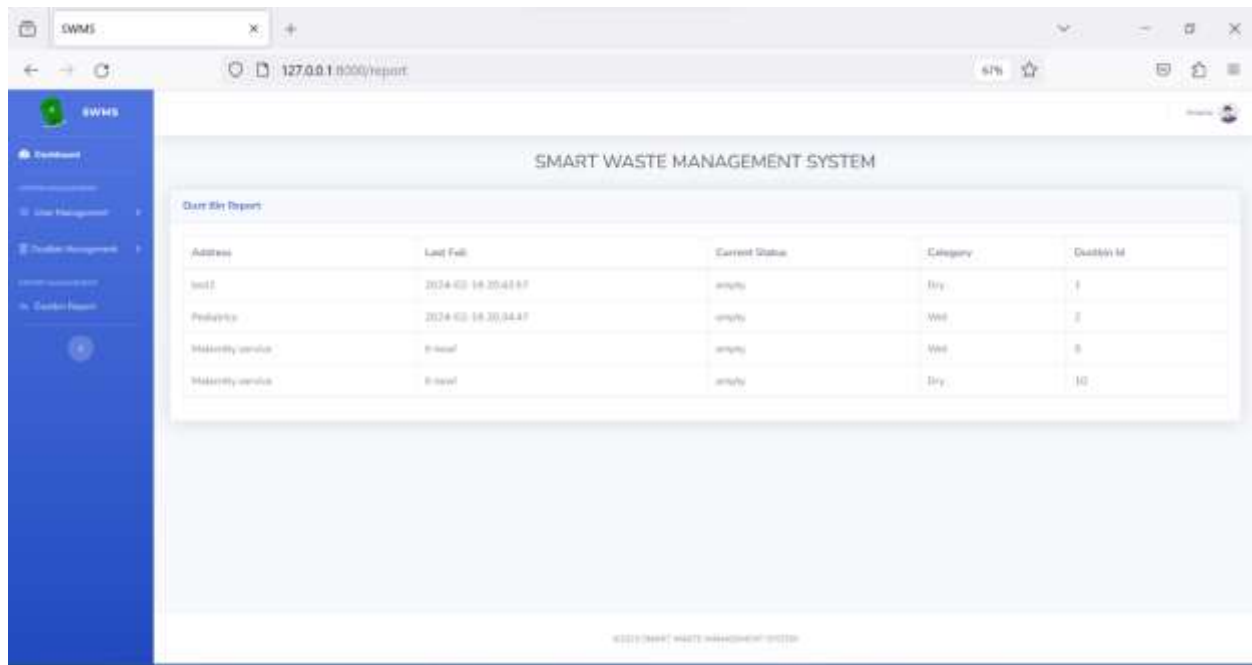

Figure 5.7:System dustbin report

#### 5.4. Challenges and Solutions:

While the registration process was overall smooth, challenges such as occasional connectivity issues were identified. These challenges were promptly addressed through technical enhancements and dedicated support channels, ensuring minimal disruption to the registration process.

The System Users Registration results and analysis underscore the importance of a streamlined and user-friendly onboarding process for the successful implementation of the Smart Waste Management System. Efficient registration, coupled with tailored training and user engagement strategies, played a pivotal role in the system's adoption and utilization. The insights derived from this analysis have informed ongoing system improvements, ensuring a seamless experience for all users and contributing significantly to the hospital's waste management efficiency and environmental sustainability[39].

## **5.5. System Performance Metrics:**

**5.5.1. Real-time Monitoring:** The implementation of smart waste management systems in healthcare facilities is becoming an essential vital to ensure efficient and sustainable waste disposal processes. Mugonero District Hospital, like many healthcare institutions, has adopted a real-time monitoring system for managing its waste effectively[40]. This analysis explores the system performance metrics of Mugonero District Hospital's smart waste management system, focusing on its real-time monitoring capabilities and their impact on the hospital's overall operational efficiency and environmental sustainability efforts[41].

### **5.5.2. System Overview:**

Mugonero District Hospital's smart waste management system is designed to monitor waste disposal processes in real-time. It utilizes sensors, data analytics, and internet connectivity to track waste generation, collection, and disposal activities. The system aims to optimize waste management operations, minimize environmental impact, and enhance the overall hygiene and cleanliness of the hospital premises[42].

### **5.5.3. Key System Performance Metrics:**

#### **5.5.3.1. Waste Generation Rate Monitoring:**

The system effectively monitors the hospital's waste generation rate, distinguishing between different types of waste such as wet and dry general waste. Real-time data on waste generation enables the hospital staff to anticipate disposal needs and plan accordingly[40].

### 5.5.3.2. Fill Levels Sensing:

Smart sensors installed in waste bins measure their fill levels such as empty level, middle level and full level. This information helps in optimizing waste collection routes and schedules, reducing unnecessary trips and saving both time and resources.



Figure 5.8:Dust bin in Empty level status



Figure 5.9:Dust bin in Middle level status



Figure 5.10:Dust bin in Full level status

### **5.5.3.3. Route Optimization and Efficiency:**

By analyzing real-time data on fill levels and waste generation rates, the system optimizes collection routes. This reduces time consumption, lowers operational costs, and minimizes the environment and air pollution associated with waste rot[43].

### **5.5.3.4. Alerts and Notifications:**

The system generates alerts see Figure 5.11 and notifications when waste bins reach a predefined fill level for wet and dry dustbins. Timely alerts ensure prompt action, preventing overflowing bins and maintaining a clean environment within the hospital premises by sending message and/or email to collector[44].

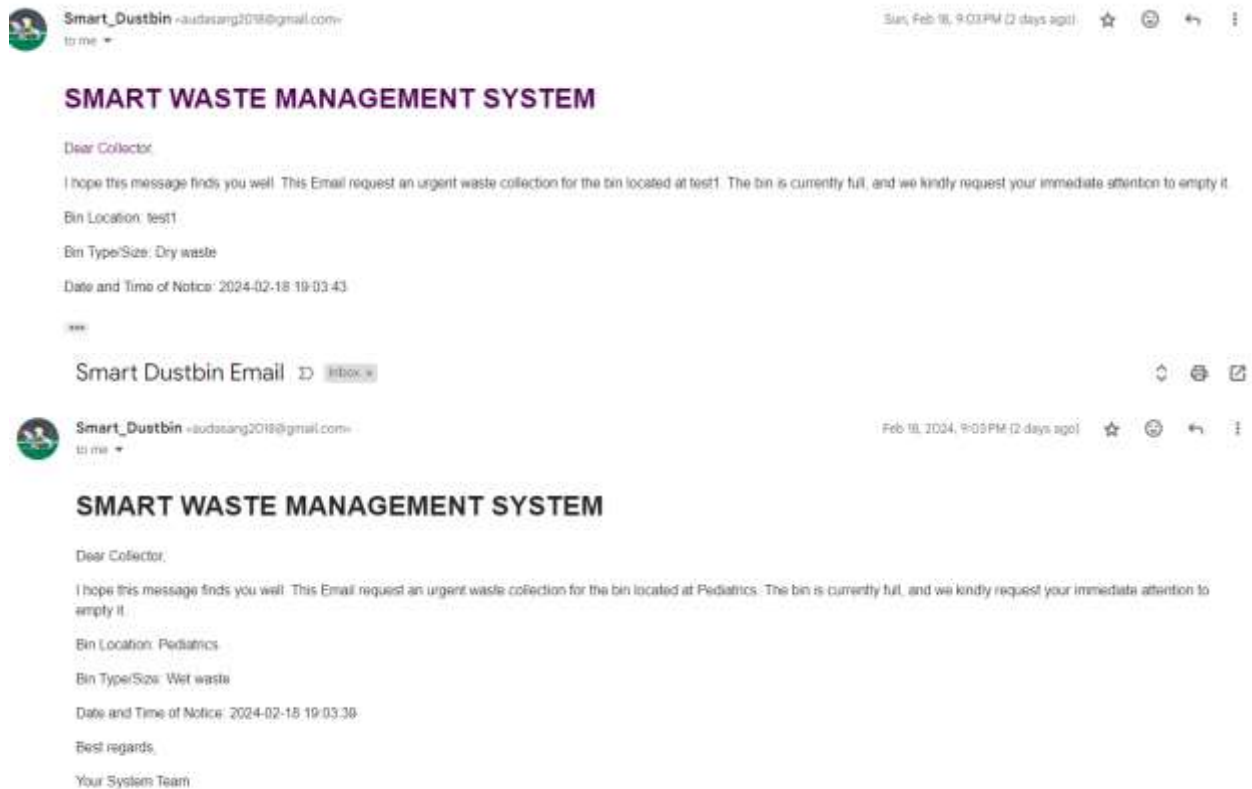

Figure 5.11:Email alert from system

#### 5.5.4. Impact on Operational Efficiency:

The implementation of real-time monitoring in Mugonero District Hospital's waste management system has significantly enhanced operational efficiency in several ways[43]:

**Time Savings:** Efficient route planning based on real-time data has reduced the time spent on waste collection, allowing hospital staff to focus on core medical activities.

With the system's ability to predict waste generation patterns, the hospital can allocate resources effectively, ensuring that waste disposal services are available when needed the most. Fewer collection trips and optimized routes have led to reduced carbon emissions, contributing to the hospital's commitment to a greener environment.

The hospital's environmentally responsible practices inspire the community to adopt similar waste management techniques, fostering a sense of environmental awareness and responsibility[43].

Mugonero District Hospital's smart waste management system, with its real-time monitoring capabilities, has proven to be a valuable asset in enhancing operational efficiency and promoting environmental sustainability. By leveraging data-driven insights, the hospital has not only reduced costs and improved resource allocation but has also set a commendable example for other healthcare facilities. Continuous monitoring and analysis of system performance metrics will further optimize the waste management process, ensuring a cleaner, greener, and more efficient healthcare environment for the community[45].

#### **5.5.5. Automated Sorting:**

Mugonero District Hospital has to implement automated sorting technology as part of its smart waste management system. This leads into the impact of automated sorting on waste segregation, operational efficiency, and environmental sustainability in the context of Mugonero District Hospital. Automated sorting ensures precise and accurate segregation of waste materials, reducing[46].

The integration of automated sorting technology into Mugonero District Hospital's smart waste management system has brought about transformative changes. This technology not only ensures the safety and well-being of healthcare workers and patients but also establishes a sustainable model for waste management that can be emulated by other healthcare facilities. Through continuous monitoring and adaptation, Mugonero District Hospital can further optimize its automated sorting processes, paving the way for a cleaner, greener, and more efficient future[47].

#### **5.6. Result Discussions**

The results of the Smart Waste Management System in Mugonero District Hospital demonstrate significant improvements in waste monitoring and collection processes. One key finding is the real-time tracking of waste levels using ultrasonic sensors, contributing to timely and efficient waste removal. The system's ability to differentiate waste types through sensors using combination of soil moisturizer sensor and infrared to enhances the hospital's waste segregation practices, aligning with environmental and safety standards[48].

The integration of the ESP8266 microcontroller and the web application has proven successful in providing a user-friendly interface for visualizing the collected data. Graphical representations

enable quick interpretation of waste trends, facilitating informed decision-making. The positive impact on operational efficiency is evident, as the hospital staff can now prioritize waste collection based on real-time data rather than fixed schedules[49].

Furthermore, the cooperative aspect of the methodology has yielded valuable insights from key stakeholders, including hospital staff and cleaners. Their active involvement in the research process has not only strengthened the system's design but has also fostered a sense of ownership and responsibility among the personnel. This participatory approach contributes to the sustainable implementation of the Smart Waste Management System[50].

However, challenges such as system scalability and potential technological barriers may require further consideration. Ensuring the system's compatibility with the hospital's existing infrastructure and addressing any technical issues will be essential for seamless integration. Ongoing cooperation and feedback mechanisms will play a crucial role in refining the system to meet the evolving needs of Mugonero District Hospital. In conclusion, the results highlight the effectiveness of the IoT-based Smart Waste Management System, offering a promising solution to enhance waste management practices in healthcare settings[51][52].

The implementation of this project stands out in the land of advancements made in waste management technologies. As compared to existing systems, several key contributions distinguish my approach, bringing significant value to the field of science and technology.

Firstly, the integration of Internet of Things (IoT) technology into the waste management system represents a notable departure from traditional methods[53]. While others have explored sensor-based solutions, my system incorporates a combination of sensors that not only monitor waste levels but also leverage real-time data analytics. This approach allows for dynamic and adaptive waste management strategies, optimizing collection routes and schedules based on current demand patterns.

In contrast to some existing solutions that primarily focus on urban environments, my smart waste management system is designed to be scalable and adaptable to diverse settings. This inclusivity ensures that the benefits of efficient waste management extend to health facilities in Rwanda, addressing the unique challenges faced by different communities.

Moreover, my system emphasizes users' engagement. Through a user-friendly interface, residents can actively participate in waste monitoring efforts. This level of users' engagement has been shown to have a positive impact on waste management practices, fostering a sense of environmental responsibility and sustainability.

The smart waste management system we have developed leverages IoT technology, and users' engagement to revolutionize waste management practices[54]. By comparing it with existing systems[55], these key additions not only enhance operational efficiency but also contribute significantly to the scientific understanding and implementation of sustainable waste management solutions[55]. This approach aligns with the broader goals of environmental conservation and resource optimization, marking a valuable contribution to the field of science and technology.

## **Chapter 6.CONCLUSION AND RECOMMENDATION**

### **6.1. Conclusion**

The implementation of a Smart Waste Management System utilizing the Internet of Things (IoT) technology in Mugonero District Hospital presents a transformative solution to address waste management challenges efficiently and sustainably. Through real-time monitoring and data-driven decision-making, this system has the potential to significantly enhance the hospital's waste management processes. The seamless integration of IoT devices allows for accurate waste level monitoring, ensuring timely collections and minimizing environmental impact. Moreover, the system's ability to optimize routes and schedules enhances operational efficiency, reducing time in the long run for checking the level of dustbins.

Beyond the operational benefits, the implementation of such a system promotes environmental sustainability by minimizing the hospital's carbon footprint. By ensuring proper waste disposal and recycling practices, the hospital can contribute positively to the local ecosystem and community well-being.

### **6.2. Recommendations**

By employing AI algorithms, the system can accurately classify different types of waste, enabling the hospital staff to segregate and dispose of them appropriately.

*Comprehensive Training:* Provide thorough training sessions for hospital staff to familiarize them with the Smart Waste Management System. Proper understanding and usage are vital for the system's effectiveness.

*Regular Maintenance:* Establish a routine maintenance schedule for IoT devices to ensure they function optimally. Regular checks and updates are essential to prevent system downtime.

*Community Engagement:* Engage with the local community to create awareness about responsible waste disposal practices. Encourage community participation to support the hospital's efforts in waste management.

*Data Analysis:* Utilize the data collected by the IoT devices for in-depth analysis. Insights derived from this data can inform future waste management strategies and help in making data-driven decisions.

*Scalability:* Design the system with scalability in mind. As the hospital grows, the waste management system should be able to accommodate increased waste generation without compromising efficiency.

*Partnerships:* Collaborate with local environmental agencies and waste management organizations. Partnerships can provide additional resources, knowledge, and support for sustainable waste management practices.

*Continuous Improvement:* Foster a culture of continuous improvement within the hospital. Regularly assess the system's performance, gather feedback from staff, and make necessary enhancements to ensure ongoing efficiency and effectiveness.

By implementing these recommendations, Mugonero District Hospital can not only optimize its waste management processes but also serve as a model for other healthcare institutions, showcasing the positive impact of integrating IoT technology in waste management systems.

## LIST OF REFERENCES

- [1] J. M. Chisholm *et al.*, “Sustainable waste management of medical waste in African developing countries: A narrative review,” *Waste Management & Research*, vol. 39, no. 9, pp. 1149–1163, 2021.
- [2] T. S. Aung, S. Luan, and Q. Xu, “Application of multi-criteria-decision approach for the analysis of medical waste management systems in Myanmar,” *J Clean Prod*, vol. 222, pp. 733–745, 2019.
- [3] A. Singh, A. Singh, and N. K. Maurya, “Health-care waste management,” *Int J Sci Res Rev*, vol. 16, no. 6, p. 1060, 2019.
- [4] M. Zamparas *et al.*, “Medical waste management and environmental assessment in the Rio University Hospital, Western Greece,” *Sustain Chem Pharm*, vol. 13, p. 100163, 2019.
- [5] A. H. Menefee and B. R. Ellis, “Wastewater management strategies for sustained shale gas production,” *Environmental Research Letters*, vol. 15, no. 2, p. 024001, 2020.
- [6] L. Andeobu, S. Wibowo, and S. Grandhi, “Artificial intelligence applications for sustainable solid waste management practices in Australia: A systematic review,” *Science of The Total Environment*, vol. 834, p. 155389, 2022.
- [7] S. Sharma, S. Upadhyay, and B. Singh, “Employment opportunities with promoting waste management in India,” *Journal Clean WAS (JCleanWAS)*, vol. 3, no. 1, pp. 10–15, 2019.
- [8] M. Thamarai and V. S. Naresh, “Smart self-power generating garbage management system using deep learning for smart cities,” *Microprocess Microsyst*, vol. 98, p. 104816, 2023.
- [9] S. Subedi, “Waste management system using the internet of things: case study of Kathmandu Valley,” 2019.
- [10] I. Hong, S. Park, B. Lee, J. Lee, D. Jeong, and S. Park, “IoT-based smart garbage system for efficient food waste management,” *The Scientific World Journal*, vol. 2014, 2014.
- [11] I. Hong, S. Park, B. Lee, J. Lee, D. Jeong, and S. Park, “IoT-based smart garbage system for efficient food waste management,” *The Scientific World Journal*, vol. 2014, 2014.
- [12] P. K. Dutta, “IOT Based Waste Management System with Metering for Smart Village Project Application,” *International Journal of Research Studies in Electrical and Electronics Engineering (IJRSEEE)*, vol. 5, no. 1, pp. 18–23, 2019.
- [13] N. A. Ismail, N. A. A. Majid, and S. A. Hassan, “IoT-based smart solid waste management system a systematic literature review,” *International Journal of Innovative Technology and Exploring Engineering*, vol. 8, no. 8, pp. 1456–1462, 2019.
- [14] D. Misra, G. Das, T. Chakraborty, and D. Das, “An IoT-based waste management system monitored by cloud,” *J Mater Cycles Waste Manag*, vol. 20, no. 3, pp. 1574–1582, 2018.

- [15] P. Raundale, S. Gadagi, and C. Acharya, "IoT based biomedical waste classification, quantification and management," in *2017 International Conference on Computing Methodologies and Communication (ICCMC)*, IEEE, 2017, pp. 487–490.
- [16] P. Raundale, S. Gadagi, and C. Acharya, "IoT based biomedical waste classification, quantification and management," in *2017 International Conference on Computing Methodologies and Communication (ICCMC)*, IEEE, 2017, pp. 487–490.
- [17] "scholar".
- [18] D. Misra, G. Das, T. Chakraborty, and D. Das, "An IoT-based waste management system monitored by cloud," *J Mater Cycles Waste Manag*, vol. 20, no. 3, pp. 1574–1582, 2018.
- [19] J. W. Creswell and J. D. Creswell, *Research design: Qualitative, quantitative, and mixed methods approaches*. Sage publications, 2017.
- [20] A. Bryman, *Social research methods*. Oxford university press, 2016.
- [21] H. Cooper, *Research synthesis and meta-analysis: A step-by-step approach*, vol. 2. Sage publications, 2015.
- [22] N. Abdullah, O. A. Alwesabi, and R. Abdullah, "IoT-based smart waste management system in a smart city," in *Recent Trends in Data Science and Soft Computing: Proceedings of the 3rd International Conference of Reliable Information and Communication Technology (IRICT 2018)*, Springer, 2019, pp. 364–371.
- [23] A. Al-Fuqaha, M. Guizani, M. Mohammadi, M. Aledhari, and M. Ayyash, "Internet of things: A survey on enabling technologies, protocols, and applications," *IEEE communications surveys & tutorials*, vol. 17, no. 4, pp. 2347–2376, 2015.
- [24] E. Datasheet, "ESP8266 Serial Esp-01 WIFI Wireless," *ESP8266 Serial Esp-01 WIFI Wireless*, p. 12, 2004.
- [25] B. Morgan Elizabeth Lim and M. Elizabeth Lim BHSc, "THE ROLE OF SYSTEMS ANALYSIS TOOLS TO INFORM HEALTHCARE DECISION MAKING TITLE: The Role of Systems Analysis Tools in Healthcare Decision Making," 2013.
- [26] A. J. Bolor, *Arduino by example*. Packt Publishing Ltd, 2015.
- [27] K. Pardini, J. J. P. C. Rodrigues, S. A. Kozlov, N. Kumar, and V. Furtado, "IoT-based solid waste management solutions: a survey," *Journal of Sensor and Actuator Networks*, vol. 8, no. 1, p. 5, 2019.
- [28] K. S. Salem *et al.*, "A critical review of existing and emerging technologies and systems to optimize solid waste management for feedstocks and energy conversion," *Matter*, 2023.
- [29] A. Ishaq, S. J. Mohammad, A.-A. D. Bello, S. A. Wada, A. Adebayo, and Z. T. Jagun, "Smart waste bin monitoring using IoT for sustainable biomedical waste management," *Environmental Science and Pollution Research*, Oct. 2023, doi: 10.1007/s11356-023-30240-1.

- [30] M. K. GHASEMI, “DEVELOPMENT OF A SUSTAINABLE HEALTHCARE WASTE MANAGEMENT MODEL USING HYBRID MULTIPLE DECISION MAKING MODEL,” 2018.
- [31] M. M. Ahmed, E. Hassanien, and A. E. Hassanien, “IoT-based intelligent waste management system,” *Neural Comput Appl*, Nov. 2023, doi: 10.1007/s00521-023-08970-7.
- [32] A. Fitriani, A. Y. Ridwan, and L. Septiningrum, “Designing Green Hospital Non-Medical Waste Management System Based on ERP,” in *2022 International Conference on Data Science and Its Applications (ICoDSA)*, IEEE, 2022, pp. 137–142.
- [33] M. Farjana, A. B. Fahad, S. E. Alam, and Md. M. Islam, “An IoT- and Cloud-Based E-Waste Management System for Resource Reclamation with a Data-Driven Decision-Making Process,” *IoT*, vol. 4, no. 3, pp. 202–220, Jul. 2023, doi: 10.3390/iot4030011.
- [34] T. Anh Khoa *et al.*, “Waste Management System Using IoT-Based Machine Learning in University,” *Wirel Commun Mob Comput*, vol. 2020, 2020, doi: 10.1155/2020/6138637.
- [35] M. W. Rahman, R. Islam, A. Hasan, N. I. Bithi, M. M. Hasan, and M. M. Rahman, “Intelligent waste management system using deep learning with IoT,” *Journal of King Saud University - Computer and Information Sciences*, vol. 34, no. 5, pp. 2072–2087, May 2022, doi: 10.1016/j.jksuci.2020.08.016.
- [36] N. F. Khan, N. Ikram, H. Murtaza, and M. A. Asadi, “Social media users and cybersecurity awareness: predicting self-disclosure using a hybrid artificial intelligence approach,” *Kybernetes*, vol. 52, no. 1, pp. 401–421, 2023.
- [37] T. Kadus, P. Nirmal, and K. Kulkarni, “Smart Waste Management System using IOT.” [Online]. Available: [www.ijert.org](http://www.ijert.org)
- [38] M. Farjana, A. B. Fahad, S. E. Alam, and M. M. Islam, “An iot-and cloud-based e-waste management system for resource reclamation with a data-driven decision-making process,” *IoT*, vol. 4, no. 3, pp. 202–220, 2023.
- [39] A. Ishaq, S. J. Mohammad, A.-A. D. Bello, S. A. Wada, A. Adebayo, and Z. T. Jagun, “Smart waste bin monitoring using IoT for sustainable biomedical waste management,” *Environmental Science and Pollution Research*, pp. 1–16, 2023.
- [40] T. Kadus, P. Nirmal, and K. Kulkarni, “Smart waste management system using IOT,” *International Journal of Engineering Research and*, vol. 9, no. 04, 2020.
- [41] J. N. Stinson *et al.*, “iCanCope with Pain™: User-centred design of a web-and mobile-based self-management program for youth with chronic pain based on identified health care needs,” *Pain Res Manag*, vol. 19, pp. 257–265, 2014.
- [42] M. Ghahramani, M. Zhou, A. Molter, and F. Pilla, “IoT-based route recommendation for an intelligent waste management system,” *IEEE Internet Things J*, vol. 9, no. 14, pp. 11883–11892, 2021.

- [43] G. S. Silva and C. Thiel, "E934-943 CASE AND COMMENTARY: PEER-REVIEWED ARTICLE What Would It Mean for Health Care Organizations to Justly Manage Their Waste?," 2022.
- [44] R. Asif and K. Ghanem, "AI secured SD-WAN architecture as a latency critical IoT enabler for 5G and beyond communications," in *2021 IEEE 18th Annual Consumer Communications and Networking Conference, CCNC 2021*, Institute of Electrical and Electronics Engineers Inc., Jan. 2021. doi: 10.1109/CCNC49032.2021.9369477.
- [45] T. Kadus, P. Nirmal, and K. Kulkarni, "Smart Waste Management System using IOT." [Online]. Available: [www.ijert.org](http://www.ijert.org)
- [46] C. Wang, Y. Ma, and G. Zhong, "IOT Monitoring System of Medical Waste Based on Artificial Intelligence," in *2021 7th Annual International Conference on Network and Information Systems for Computers (ICNISC)*, IEEE, 2021, pp. 139–143.
- [47] M. Ghahramani, M. Zhou, A. Molter, and F. Pilla, "IoT-based route recommendation for an intelligent waste management system," *IEEE Internet Things J*, vol. 9, no. 14, pp. 11883–11892, 2021.
- [48] A. Ishaq, S. J. Mohammad, A.-A. D. Bello, S. A. Wada, A. Adebayo, and Z. T. Jagun, "Smart waste bin monitoring using IoT for sustainable biomedical waste management," *Environmental Science and Pollution Research*, Oct. 2023, doi: 10.1007/s11356-023-30240-1.
- [49] D. Shah, M. Relia, and S. Patel, "Decentralized Waste Management System: Smart Dustbin," in *ICT with Intelligent Applications*, J. Choudrie, P. Mahalle, T. Perumal, and A. Joshi, Eds., Singapore: Springer Nature Singapore, 2023, pp. 347–355.
- [50] L. T. Vasconcelos, F. Z. Silva, F. G. Ferreira, G. Martinho, A. Pires, and J. C. Ferreira, "Collaborative process design for waste management: co-constructing strategies with stakeholders," *Environ Dev Sustain*, vol. 24, no. 7, pp. 9243–9259, Jul. 2022, doi: 10.1007/s10668-021-01822-1.
- [51] H. Yadav, U. Soni, and G. Kumar, "Analysing challenges to smart waste management for a sustainable circular economy in developing countries: a fuzzy DEMATEL study," *Smart and Sustainable Built Environment*, vol. 12, no. 2, pp. 361–384, Jan. 2023, doi: 10.1108/SASBE-06-2021-0097.
- [52] H. Yadav, U. Soni, and G. Kumar, "Analysing challenges to smart waste management for a sustainable circular economy in developing countries: a fuzzy DEMATEL study," *Smart and Sustainable Built Environment*, vol. 12, no. 2, pp. 361–384, Jan. 2023, doi: 10.1108/SASBE-06-2021-0097.
- [53] R. Singh, "Integration of informal sector in solid waste management: Strategies and approaches," *Centre for Science and Environment, New Delhi*, vol. 18, 2021.

- [54] R. Bai and M. Sutanto, "The practice and challenges of solid waste management in Singapore," *Waste management*, vol. 22, no. 5, pp. 557–567, 2002.
- [55] T. Bhuvaneswari, J. Hossen, N. A. A. Hamzah, P. Velraj Kumar, and O. H. Jack, "Internet of things (IoT) based smart garbage monitoring system," *Indonesian Journal of Electrical Engineering and Computer Science*, vol. 20, no. 2, pp. 736–743, 2020.

## **APPENDIX I**

### **SURVEY QUESTIONNAIRE: SMART WASTE MANAGEMENT SYSTEM**

Thank you for taking the time to participate in this questionnaire. Your valuable insights will help us better understand the potential benefits and challenges of implementing a smart waste management system in **MUGONERO District Hospital**.

#### **SECTION 1: GENERAL INFORMATION**

1. What is your role in the hospital?

- Healthcare Provider (Doctor, Nurse, etc.)
- Administrative Staff
- Facilities Management
- Cleaner
- Other (please specify): \_\_\_\_\_

2. How familiar are you with the concept of a smart waste management system?

- Very familiar
- Somewhat familiar
- Not familiar at all

#### **SECTION 2: CURRENT WASTE MANAGEMENT PRACTICES**

1. How is waste currently managed in the hospital? (Check all that apply)

- Segregation of waste into categories (e.g., medical waste, general waste)
- Use of color-coded bins for waste separation
- Regular waste collection schedule
- External waste management service provider
- Other (please specify): \_\_\_\_\_

2. What are the main challenges you face with the current waste management practices, if any?

### **SECTION 3: SMART WASTE MANAGEMENT SYSTEM**

1.Are you aware of the potential benefits of implementing a smart waste management system?

(Check all that apply)

- Improved waste segregation
- Real-time monitoring of waste levels
- Reduced risk of contamination and infection
- Optimized waste collection routes
- Better compliance with waste disposal regulations
- Enhanced sustainability and environmental impact
- Other (please specify): \_\_\_\_\_

2.What features would you consider important in a smart waste management system? (Rank in order of importance: 1 = Most important, 5 = Least important)

- Real-time waste level monitoring
- Automatic waste sorting
- Notifications for waste collection
- Data analytics and reporting
- Integration with existing hospital systems

3.What concerns or challenges do you foresee in implementing a smart waste management system in the hospital?

### **SECTION 4: IMPLEMENTATION AND ADOPTION**

1.How open are you to the adoption of new technologies like a smart waste management system?

- Very open
- Somewhat open
- Neutral
- Somewhat resistant

Very resistant

2.What factors do you believe would facilitate the successful implementation of a smart waste management system in the hospital?

3.Would you be interested in participating in pilot testing or training programs for the new system?

Yes

No

### **SECTION 5: ADDITIONAL COMMENTS**

1.Please provide any additional comments, suggestions, or insights related to smart waste management in the hospital.

Thank you for your participation! Your input is highly appreciated and will contribute to our decision-making process regarding the implementation of a smart waste management system in the hospital.

## Appendix II

```
#include <ESP8266WiFi.h>
#include <ESP8266HTTPClient.h>
const char* ssid = "MAICOLTD-COMPANY";
const char* password = "Maicoltd@2023!";
const char* serverAddress = "http://192.168.1.
135:8003/api/status/update";
const char* serverAddress1 = "http://192.168.1.
135:8003/api/status/update1";
const int trigPin_1 = 12;
const int echoPin_1 = 14;
const int trigPin_2 = 5;
const int echoPin_2 = 4;
#define SOUND_VELOCITY 0.034
long duration_1;
float distanceCm_1;
long duration_2;
float distanceCm_2;
void setup()
{
  Serial.begin(9600);
  WiFi.begin(ssid, password);
  while (WiFi.status() != WL_CONNECTED)
  {
    delay(1000);
    Serial.println("Connecting to WiFi...");
  }
  Serial.println("Connected to WiFi");
  pinMode(trigPin_1, OUTPUT);
```

```

pinMode(echoPin_1, INPUT);
pinMode(trigPin_2, OUTPUT);
pinMode(echoPin_2, INPUT);
}
void loop()
{
digitalWrite(trigPin_1, LOW);
delayMicroseconds(2);
digitalWrite(trigPin_1, HIGH);
delayMicroseconds(10);
digitalWrite(trigPin_1, LOW);
duration_1 = pulseIn(echoPin_1, HIGH);
digitalWrite(trigPin_2, LOW);
delayMicroseconds(2);
digitalWrite(trigPin_2, HIGH);
delayMicroseconds(10);
digitalWrite(trigPin_2, LOW);
duration_2 = pulseIn(echoPin_2, HIGH);
distanceCm_1 = duration_1 * SOUND_VELOCITY/2;
distanceCm_2 = duration_2 * SOUND_VELOCITY/2;
Serial.print("Distance_1 (cm): ");
Serial.println(distanceCm_1);
Serial.print("Distance_2 (cm): ");
Serial.println(distanceCm_2);
if (distanceCm_1 > 32)
{
accessApi1("empty");
}
else if (distanceCm_1 < 32 && distanceCm_1 >= 23)

```

```
{
accessApi1("low");
}
else if (distanceCm_1 < 23 && distanceCm_1 >= 7 )
{
accessApi1("medium");
}
else if (distanceCm_1 < 7)
{
accessApi1("full");
}
if (distanceCm_2 > 32)
{
accessApi2("empty");
}
else if (distanceCm_2 < 32 && distanceCm_2 >= 23)
{
accessApi2("low");
}
else if (distanceCm_2 < 23 && distanceCm_2 >= 7 )
{
accessApi2("medium");
}
else if (distanceCm_2 < 7)
{
accessApi2("full");
}
delay(1000);
}
```

```

void accessApi1(String data)
{
  HTTPClient http;
  WiFiClient client;
  // Your API endpoint URL
  http.begin(client, serverAddress);
  // Set headers
  http.addHeader("Content-Type", "application/json");
  // JSON data to send
  String name = data;
  String postData = "{\"status\": \"\"+name+\"\",
  \"id\": \"1\"}";
  Serial.println(postData);
  // Send POST request
  int httpResponseCode = http.POST(postData);
  if (httpResponseCode > 0)
  {
    Serial.print("HTTP Response code: ");
    Serial.println(httpResponseCode);
    String response = http.getString();
    Serial.println(response);
  }
  else
  {
    Serial.print("Error code: ");
    Serial.println(httpResponseCode);
  }
  http.end();
}

```

```
void accessApi2(String data)
{
  HTTPClient http;
  WiFiClient client;
  // Your API endpoint URL
  http.begin(client, serverAddress1);
  // Set headers
  http.addHeader("Content-Type", "application/json");
  // JSON data to send
  String name = data;
  String postData = "{\"status\": \"\"+name+"\",
  \"id\": \"2\"}";
  // Send POST request
  int httpResponseCode = http.POST(postData);
  if (httpResponseCode > 0)
  {
    Serial.print("HTTP Response code: ");
    Serial.println(httpResponseCode);
    String response = http.getString();
    Serial.println(response);
  }
  else
  {
    Serial.print("Error code: ");
    Serial.println(httpResponseCode);
  }
  http.end();
}
```