



UNIVERSITY of
RWANDA

COLLEGE OF SCIENCE AND TECHNOLOGY



Website: www.aceiot.ur.ac.rw

Mail: aceiot@ur.ac.rw

AFRICA CENTER OF EXCELLENCE IN INTERNET OF THINGS (ICE-IoT)

Research Thesis Title:

Design and implementation of rotating IoT based sunlight trucking system and comparative study between fixed and rotating sunlight system in terms of voltage generating.

A dissertation Submitted in Partial Fulfilment of the Requirements for The Award of Master's Degree in Internet of Things: Embedded Computing Systems

Submitted by:

NIYIGENA Flavien REF.NO: 223010600

September, 2024



UNIVERSITY of
RWANDA

COLLEGE OF SCIENCE AND TECHNOLOGY



Website: www.aceiot.ur.ac.rw

Mail: aceiot@ur.ac.rw

Research Thesis Title:

Design and implementation of rotating IoT based sunlight tracking system and comparative study between fixed and rotating sunlight system in terms of voltage generating.

A dissertation Submitted in Partial Fulfilment of the Requirements for The Award of Master's Degree in Internet of Things: Embedded Computing Systems

Submitted by:

NIYIGENA Flavien REF.NO: 223010600

Supervisor: Dr MUKANYIRIGIRA Didacienne

Co-Supervisor: Dr MASABO Emmanuel

September, 2024

STUDENT DECLARATION

I declare that this Dissertation contains my own work except where specifically acknowledged.

Flavien Niyigena

223010600

Signature:

Date:

BONAFIDE CERTIFICATE

This is to certify that the project entitled “Design and implementation of rotating IoT based sunlight trucking system and comparative study between fixed and rotating sunlight system in terms of voltage generating” is a record of original work done by Flavien Niyigena with registration number 223010600 in partial fulfilment of the requirement for the award of masters of sciences in Internet of Things in College of Science and Technology, University of Rwanda, Academic year 2022/2023

This work has been submitted under the guidance of Dr. Didacienne Mukanyiligira and Dr. Emmanuel Masabo

Main Supervisor: Dr. Didacienne Mukanyiligira Co-Supervisor: Dr. Emmanuel Masabo

Signature:

Signature:

Date:

Date:

The Head of Masters and Trainings

Dr. James Rwigema

Signature :

Date :

ACKNOWLEDGEMENT

I am grateful for the almighty God for blessings upon my life and leading me this far. I thank him for the good health and resources that made it possible for me to undertake this research.

I would like to acknowledge the invaluable support offered by my supervisors' Dr. Didacienne Mukanyiligira and Dr. Emmanuel Masabo. I thank you for your dedicated support and guidance throughout the process. I do appreciate your encouragement and willingness to share your experiences. You have installed in me a sense of self confidence and adequacy to conduct this and future research. I have learnt a lot from your supervision and I will be forever grateful.

My sincere appreciation goes to my loving family; to my dear wife Olive Uwanyirigira, my daughters Mbabazi and Keza, my parents, my brothers, my workmates especially my former Director Blandine Uwimana for your prayers and encouragement during this research. I thank you for your patience, moral support and understanding.

I also appreciate the moral support of the staff from ACEIoT and my colleagues and friends, specifically Emmanuel, Claude and Yvonne. Thank you for your encouragement, ideas and for being there. To all my lecturers that saw me through the course. I thank you.

It is impossible to register the names of all those who assisted me, I appreciate you all, for everything glory and honour be to God, I have come this far.

ABSTRACT

This research work addresses a solution for the problem of optimization of solar energy with respect to voltage output by doing a comparison of the fixed and the rotating solar system. While fixed solar panels are simpler and less expensive, they may not capture full-day sunlight properly and hence result somewhat suboptimal energy production. For this reason, due to the benefits derived from the movement of solar systems and the fact that their working system is rotating with the movement of the sun, the research is basically inclined to establish that this system is a better one in respect to voltage generation than the other. Hence, the main objectives for which the present test is designed are to quantify the difference in voltage generation of the two systems and to determine whether the gains in energy efficiency justify increased complexity and cost of a rotating system. The two solar systems were to be installed in the region: the system of the fixed panel and rotating panel solar. With consideration of right intensity every hour for the specified duration, records and measurements were done over the output voltage. In average form, the fixed solar system can be seen to generate 19 volts in one hour by average, whereas average of 24.06 volts in one hour can be realized by the ships using a rotating system. This 26.7% increased output voltage shows really well how essentially advantageous the rotating system is, in harnessing the optimal energy capture. From these results, it can be deemed that the investment brought about by rotating solar systems will be really huge in making energy capture maximally possible, especially in locations where the daily variations of sunlight angles are significant. The work has, therefore, added to the discussion of some of the value chains in gains that IoT technology holds with respect to augmentation in solar energy systems and more precisely in voltage generation and energy storage. Results confirm that the IoT-based rotating system offers a clear edge over the fixed system and quite proactive in capturing solar energy. These results have an important bearing on the design of future solar energy systems and their deployment in areas with different sunning conditions. The fact that IoT was applied successfully in this study proves it to be a key driver of innovation and efficiency in renewable energy technologies, opening channels for more sustainable and effective energy solutions.

Keywords: *IoT, Solar energy, real-time data, fixed solar panels, rotating solar systems, Voltage generation, energy efficiency*

LIST OF ACRONYMS

AC: Alternative current

DC: Direct current

DFR: Data flow diagram

IoT: Internet of Things

KWP: Kilowatt peak

LCD: Liquid crystal display

LDR: Light Dependent Resistor

LED: Light Emitting Diode

MoU: Memorandum of Understanding

MW: Mega watt

PCB: Printed circuit board

PDL: Program design language

PV: Photo Voltaic

PWM: Pulse-Width modulation

UR: University of Rwanda

LIST OF FIGURES

Figure 4.1: Data flow diagram.....	28
Figure 4.2: System design in proteus.....	29
Figure 4.3: Hardware connectivity.....	30
Figure 5.1: Battery level display	39
Figure 5.2: Voltages of fixed system over time.....	40
Figure 5.3: Voltages of rotating system over time	44

LIST OF TABLES

Table 3.1: Hardware components.....	23
Table 4.1: Data captured by fixed solar system from 6am to 9am	31
Table 4.2: Data captured by rotating solar tracking system 6am to 9am.....	32
Table 4.3: Data captured by fixed solar system from 9am to 12am.....	38
Table 4.4: Data captured by rotating solar system from 9am to 12am.....	39
Table 4.5: Data captured by fixed solar system from 12am to 3pm.....	40
Table 4.6: Data captured by rotating solar system from 12am to 3pm.....	41
Table 4.7: Data captured by fixed solar system from 3pm to 6pm.....	42
Table 4.8: Data captured by rotating solar system from 3pm to 6pm.....	43

TABLE OF CONTENTS

STUDENT DECLARATION	i
BONAFIDE CERTIFICATE	iii
ACKNOWLEDGEMENT	iv
ABSTRACT	v
LIST OF ACRONYMS	vi
LIST OF FIGURES	vii
LIST OF TABLES	viii
TABLE OF CONTENTS	ix
CHAPTER 1: INTRODUCTION	1
1.1 Introduction	1
1.2 Problem statement	2
1.3 Relational and literature review	3
1.4 Aims and objectives of the study	4
1.4.1 Main objective	4
1.4.2 Specific objectives	5
1.5 Study scope	5
1.6 Research hypothesis	5
1.7 Significance of the study	5
1.8 Organization of the study	6
CHAPTER 2: LITERATURE REVIEW	7
2.1 Introduction	7
2.2 Solar energy	7
2.3 Solar energy in Rwanda	8
2.4 Solar energy in Africa	10
2.8 Types of solar tracking system	16

2.8.1 Single axis Solar tracker	16
2.8.2 Dual axis solar tracker	17
2.9 Advantages of solar tracking system	18
2.10 Related works	18
2.11 Gaps found in existing researches.....	20
CPAPTER 3: METHODOLOGY.....	21
3.1 Introduction.....	21
3.2 System block diagram.....	21
3.3 Hardware components.....	22
3.4 System development methodology	23
3.5 Data collection technique.....	24
3.6 System requirements.....	25
3.7 Tools and languages	25
3.7.1 Arduino IDE	25
3.8 Data analysis.....	25
CHAPTER 4: SYSTEM ANALYSIS AND DESIGN.....	27
4.1 Introduction.....	27
4.2 Data flow diagram.....	27
4.3 System design in Proteus	28
4.4 Hardware connectivity	29
4.5 Data gathering.....	30
4.6 Data collected by fixed system.....	31
4.7 Data collected by rotating system	32
CHAPTER 5: RESULTS AND ANALYSIS	38
5.1 Result and analysis.....	38
5.1.1 Rotating solar tracking system.....	38
5.1.2 Data display on LCD.....	38

5.1.3 Voltages of fixed system over time	39
5.1.4 Statistical analysis fixed solar system	39
5.1.6 Statistical analysis of data captured by rotating system.....	41
5.1.8 Error margin	51
5.1.9. Discussion.....	43
CHAPTER 6: CONCLUSION AND RECOMMENDATION	53
6.1 Conclusion	53
6.2 Recommendations	53
6.2.1 To owners of solar power plants	54
6.2.2 To the University of Rwanda.....	54
6.2.3 To the government of Rwanda	54
6.2.4 To future researchers.....	54
REFERENCES.....	55

CHAPTER 1: INTRODUCTION

1.1 Introduction

Currently, solar energy stands out as a highly promising energy source applicable in various domains like residential, industrial, and electric vehicle charging. It serves as a resilient and sustainable alternative to address the issues of air pollution and the greenhouse effect associated with conventional energy sources such as fossil fuels. Additionally, solar energy presents a hopeful remedy to mitigate the elevated expenses of electricity, a significant obstacle to development in numerous countries, including Rwanda.

The widespread adoption of solar energy for powering residential spaces has become prevalent. The evident advantage of utilizing a renewable and eco-friendly energy source has spurred increased research and development in solar harvesting technology. The stationary installation of solar panels, affected by the sun's movement throughout the day, appears less efficient in capturing power compared to installations equipped to track the sun's trajectory. Hence, solar systems with the capability to track the sun and adjust panel orientation offer numerous advantages over static systems.

This study investigates the distinctions between a fixed solar panel system and a solar panel system equipped with tracking capabilities using IoT technology, as discussed by Us et al. (2018). The effectiveness of solar panels relies on various factors, such as the angle and alignment of the panels in relation to the sun, as well as the cleanliness of the panel surfaces. Moreover, the performance of solar panels sees a notable improvement with regular cleaning of their surfaces.

The tracking movement is accomplished by connecting a servo motor to the solar panel, ensuring that the panel maintains a constant alignment perpendicular to the sun for optimal energy generation. This process involves a programmed microcontroller delivering stepper pulses at regular intervals, causing the servo motors to rotate the mounted panel in one direction and return to the starting position for the next day's sunlight exposure. According to established measurements, the average power density of solar radiation just beyond the Earth's atmosphere is 1366W/m^2 , commonly referred to as the solar constant. The annual solar energy reaching the Earth

amounts to 5460000EJ/year, which is a thousand times greater than the world's total annual energy consumption (Alharthi et al., 2018).

The global demand for renewable energy is on the rise, with solar power emerging as a widely adopted source. To enhance its efficiency, solar tracking systems have been developed, offering the advantage of maximizing sunlight exposure to the solar panels and thereby increasing their power output. Various studies have delved into different solar tracking algorithms aimed at improving system efficiency. Among these, the dual-axis solar tracking algorithm stands out, utilizing sensors to identify the sun's position and calculate optimal angles for aligning the solar panel with the sun. Motors are then employed to adjust the panel's orientation based on the calculated angles. In recent years, the Internet of Things (IoT) has shown promise in boosting the performance of solar tracking systems. IoT-based solar tracking systems incorporate sensors to gather data on sun alignment, which is subsequently transmitted to Arduino for analysis (Jafri et al., 2023).

In this research, I plan to conduct a comparative study between the two system fixed and rotating system I terms of voltage generation. Due to the limited budget, this study will involve first setting fixed solar system installation secondly, this fixed will be turned into rotating panel that tracks the sun's movement throughout the day by adding IoT devices and program codes. By continuously monitoring and recording the voltage output from both systems under identical environmental conditions, I will analyze how the ability of the rotating system. This research aims to provide the valuable insights on comparative energy generation in terms of voltages. It aims to show statistically in terms of numbers the different existing in terms of energy generated.

1.2 Problem statement

Solar energy has established as an important ingredient in sustainable energy solutions, yet this process is dependent on maximizing sunlight captured through photovoltaic systems. It offers a basic solution with sunlight tracking, which may not optimize the generation of energy in regard to its position throughout the day. In connection with this, rotating IoT-based systems for sunlight tracking become very interesting due to their ability to change the orientation of the solar panel in real-time on available sunlight data. However, the engineering challenges in designing and

implementing such systems are huge with respect to integration with precision sensors, actuators, and IoT infrastructure for their proper solar tracking. Understanding comparative performance in voltage generation between fixed and rotating systems would be terrible in establishing their practical feasibility and economic feasibility in their application in solar energy.

This comparative study will therefore determine the effectiveness and efficiency of both fixed and rotating sunlight tracking systems in voltage generation. The overall generation of energy through a solar PV system that is, its operational efficiency and thereby its economic viability and its environmental impacts are directly impacted by voltage generation. Fixed systems have simpler designs and deployment; however, it may face limitations caused by the adjustment ability with regards to the different angles of sunlight and its intensities throughout the day and over the seasons. On the other hand, rotating IoT-based systems are expected to play a role in maximizing energy yield by continuously reorienting themselves toward the sun's position. This research work carries out a detailed comparative analysis for the quantification of the energy conversation rates, daily energy production profiles, and system reliability differences of fixed and rotating sunlight tracking systems. These findings will be informative in optimizing the technologies of solar energy generation and will help make decisions in the process of developing renewable energy infrastructure.

1.3 Relational and literature review

Solar energy stands out as the most plentiful and extensively distributed form of energy accessible on Earth. Presently, solar photovoltaic (PV) power generation has emerged as the swiftest growing energy technology globally, owing to its maturity and scalability. Predicted to spearhead investments in power generation technology from 2017 to 2040, this technology is anticipated to surpass nuclear, wind, and gas generation capacities worldwide, primarily due to its relatively low cost.

However, there is a need for additional reductions in system-level costs to sustain the decline in expenses while adhering to crystalline silicon wafer-based technology, which constitutes 90% of global production and achieves a maximum energy conversion of 26%. Despite the potential of various emerging technologies for more economical manufacturing and deployment, none have achieved large-scale commercial production thus far. Most of these technologies encounter

numerous challenges related to scaling limits of photovoltaic (PV) materials, manufacturing intricacies, and overall costs.

As per the findings, although crystalline silicon wafer-based technology exhibits several advantages in mitigating global environmental impacts, its current utilization faces two constraints: the elevated production cost and lower efficiency when compared to alternative sources. The study introduces a classification scheme for photovoltaic (PV) technology, taking into account material complexity and energy conversion efficiency (Kumbhar et al., 2021).

The demand for electrical energy is on a constant rise, leading to the utilization of various power sources in modern power systems. Researchers are actively working on enhancing the efficiency of power systems, and one aspect of this research involves solar tracking systems to optimize power sources. Solar tracking is a method employed to maximize the exposure of solar panels to sunlight, extracting more power from them. Various techniques have been developed for solar tracking systems, utilizing a device known as a solar tracker. Typically orienting solar panels, the tracker employs a servo motor to achieve the necessary movement, ensuring that the panel consistently faces the sun perpendicular to generate maximum energy (El Hammoumi et al., 2021).

This is accomplished by utilizing a programmed microcontroller to emit stepper pulses at regular intervals, enabling servo motors to rotate the mounted panel in one direction and then return to the starting point for the next day's exposure to light, as needed. The construction of a solar panel must be designed to withstand external challenges. It should be resilient against elements such as wind, rain, prolonged exposure to UV radiation, and more. Additionally, the panel must be robust during handling and transportation, and its external fixing features must be dependable when mounting it onto a roof or other systems. According to Lin (2015), most solar panels typically generate peak power levels ranging from 200 to 350W per panel, contingent on factors like the panel's size and the technology employed, such as monocrystalline or polycrystalline. Renewable energy devices harness energy from sustainable sources.

1.4 Aims and objectives of the study

1.4.1 Main objective

The main objective of this research is to develop a prototype of a rotating IoT-based sunlight tracking system integrating sensors, actuators, and IoT infrastructure to dynamically adjust solar

panel orientation based on real-time sunlight data and compare voltages generating by fixed and rotating IoT based sunlight tracking system.

1.4.2 Specific objectives

- ✓ To analyze existing research on fixed and rotating solar systems and develop innovative solutions.
- ✓ To develop a tracking system that controls and monitors the movement of solar panel based on the intensity of light along time of the day.
- ✓ To do comparative analysis of voltage generation by fixed and rotating system
- ✓ To integrate Internet of things and real-time data analytics

1.5 Study scope

This study focuses on the design and implementation of IoT based solar tracking system and make comparative study between fixed and rotating solar trucking system. Due to time constraints, limited resources and availability of datasets, the study was conducted in six months and data used in comparison are from the designed systems.

1.6 Research hypothesis

IoT based solar tracking system and comparative study between solar tracking system and fixed solar trucking system. This research aims to design and develop the said systems and use them to collect data to be used in comparison of both systems. This research will help to show how solar tracking systems can be designed for more efficient in terms of voltage generating.

1.7 Significance of the study

The anticipated outcome of this study is the creation of an IoT-based sunlight tracking system with rotational capabilities. Additionally, a comparative analysis between fixed and rotating IoT-based sunlight tracking systems will be conducted, focusing on the generated voltages to enhance the efficiency of solar panel systems. The implementation of this system is expected to significantly impact the quantity of solar energy captured by solar panel systems, consequently influencing electricity prices positively. The

proposed system holds substantial promise for community benefits, positively impacting economic aspects, environmental considerations, and overall community welfare.

Conversely, given the high cost of electricity in Rwanda, there is a pressing need to explore alternative energy sources. Solar energy emerges as a promising alternative to alleviate the expenses of electricity and decrease reliance on fossil fuels, particularly in transportation.

1.8 Organization of the study

This study is structured into five chapters. In Chapter One, the research background is introduced, along with the research motivation. It provides an overview of the technologies involved and outlines the problems addressed, setting the objectives. The chapter also delineates the study scope, discusses the significance, and presents the organizational structure of the project. Chapter One concludes with a summary.

Moving to Chapter Two, the subsequent section provides a literature review related to the research topic. Chapter Three outlines the methods employed in this research thesis, encompassing system design, the prototype model, and relevant parameters. Chapter Four delves into the presentation and analysis of the obtained results, utilizing graphs for a comprehensive understanding. Finally, Chapter Five serves as the conclusion, summarizing the discussion and offering final remarks.

CPAPTER 2: LITERATURE REVIEW

2.1 Introduction

This chapter elucidates the theoretical concepts and essential definitions utilized in the current study. The primary aim is to furnish valuable information and elucidate various technologies and techniques employed in the research. Additionally, the chapter provides an overview of previous research related to the current study conducted by other researchers.

2.2 Solar energy

This chapter elucidates the theoretical concepts and essential definitions utilized in the current study. The primary aim is to furnish valuable information and elucidate various technologies and techniques employed in the research. Additionally, the chapter provides an overview of previous research related to the current study conducted by other researchers.

These sources of energy can be classified into solar, geothermal, hydroelectricity, wind, tide/wave/ocean, biofuels, and municipal waste. The pursuit of these alternative energy options is driven by a global focus on sustainability, driven by concerns such as global warming, pollution, climate change, and the depletion of natural resources. These challenges have been further intensified by the increasing demand for energy worldwide. In the Moroccan context, the road transportation sector accounted for approximately 15% of the total greenhouse emissions in the country as of 2014.

The annual growth rate for motor vehicles stands at approximately 4-5%, with the year 2014 recording 3.4 million combustion motor vehicles, of which two-thirds are more than a decade old. This growth trajectory is on the rise, fueled by the increasing momentum in the automotive industry in Morocco, driven by heightened investments from private investors and car part manufacturers in the region. These combustion vehicles contribute to air pollution primarily through the emission of exhaust fumes into the atmosphere. Consequently, epidemiological studies conducted in the regions of Casablanca, Safi, and Mohammed have established a direct correlation between air pollution and respiratory diseases.

2.3 Solar energy in Rwanda

According to Eustache (2019) Rwanda experiences abundant solar energy, even during the rainy seasons, with consistent and ample sunshine, particularly in the Eastern province renowned for its high irradiance values. The daily global solar irradiation on a tilted surface is estimated at 5.2 kWh per m² per day, according to the Photovoltaic Geography Information System. The long-term average daily global irradiation ranges from 4.8 kWh/m²day to 5.8 kWh/m²day, indicating a significant potential for solar energy development. Currently, Rwanda's total on-grid installed solar energy capacity stands at 12.08 MW.

Households situated beyond the scope of the planned national grid are being encouraged to opt for standalone solar photovoltaic (PV) systems as a means to lower the expenses associated with electricity access. The approved Rural Electrification Strategy in Rwanda, established in June 2016, delineates strategies aimed at ensuring that households in Rwanda gain access to electricity through the most cost-effective means. This involves developing programs that facilitate end-users' access to more economical technologies and fostering increased private sector involvement in providing these solutions (Renewable & Programme, 2014). The Energy sector strategic plan emphasizes achieving universal access to electricity by 2024, with 48% of households being connected through off-grid power systems.

The Mount Jali 250KWP Solar Plant in Kigali was initiated through a Memorandum of Understanding (MoU) signed in 2006 between the Rwandan government and the German state of Rhineland-Palatinate. The agreement aimed to construct, own, and operate a 250 KWP grid-connected solar plant, with commissioning completed in 2007. Funded by the German municipal power company Stadtwerke Mainz, the installation was carried out by July 2008 on Mount Jali in Kigali City. The plant has been operational since its commissioning. The Rwamagana Solar Power Plant, with a capacity of 8.3 MW and a total cost of US\$23.7 million, was developed in collaboration with Gigawatt Global. Located near the Agahozo Shalom Youth Village in Rwamagana District, this plant, commissioned in February 2015, stands as the first utility-scale solar power facility in East Africa. Furthermore, the Nasho Solar Power Plant, generating 3.3 MW, was established and commissioned in 2017. Its primary purpose is to provide solar energy for the irrigation system, with surplus energy used to illuminate homes in the vicinity. The project

received funding from the Howard G. Buffett Foundation, in collaboration with the Ministry of Agriculture (Bensch et al., 2012).

The adoption of renewable energy plays a crucial role in mitigating global warming, and notably, there has been a growing emphasis on the development of photovoltaic systems in recent years due to their positive impact on conserving natural resources globally. The finite nature of fossil fuel-based energy sources and their contribution to global climate change underline the importance of transitioning towards sustainable alternatives. Harnessing green and clean energy, such as solar power through photovoltaic systems, not only aids in environmental protection but also addresses the challenge of limited electricity access in remote areas.

In Rwanda, the issue of electricity access is particularly acute, especially in rural areas, posing a significant hurdle to the country's sustainable development. Current statistics indicate that only approximately 23% of the population has access to grid-connected electricity, with a mere 5% of rural villages connected to the national grid. Moreover, the demographic distribution highlights that 85% of the Rwandan population resides in rural areas, while only 15% constitutes urban citizens (Ministry of Infrastructure, June 2016).

In these areas, the predominant activity is agriculture, primarily focused on securing food and meeting basic life necessities. In the case of Rwanda, where a substantial portion of the population resides in rural regions, the challenge lies in extending energy access and promoting development in other economic sectors. The configuration of Rwanda's electric grid is a critical factor. Currently, the electricity demand is concentrated in urban areas and business centers, with power generated from various plants primarily distributed through single lines due to the predominantly radial nature of the transmission network. However, the extension of the grid faces economic constraints, including the high cost of electricity, making it unaffordable for rural consumers. Additionally, geographical conditions pose challenges, making it difficult for individuals in remote areas, far from the grid lines, to access power. The absence of alternative paths for electricity in the transmission network further compounds the issue, negatively impacting power services in rural areas and compelling residents to migrate to urban centers. This paper will delve into the vulnerability of rural areas in providing a more reliable and effective solution for rural electrification in Rwanda, exploring potential strategies and their implications.



Figure 2.1: Utility scale of 8.5MW PV power plant constructed in Agahozo Shalom Youth Village in Rwanda

Rwanda possesses significant prospects for harnessing energy from various sources such as hydro power, methane gas, solar, and peat deposits. Approximately 1,200 MW of untapped resources for power generation remain available, yet these sources have not been fully utilized. Despite these opportunities, wood remains the primary energy source for 94 percent of the population, and over 40 percent of foreign exchange is allocated to imported petroleum products. The current energy supply situation is recognized as a hindrance to sustainable development due to its inadequacy and high costs. In alignment with Rwanda's Vision 2020, which prioritizes economic growth, private investment, and economic transformation, a reliable and affordable energy supply is identified as crucial for the development process. To realize this vision, the country must enhance energy production and explore alternative energy sources, as highlighted by Eustache et al. in 2019.

2.4 Solar energy in Africa

A comprehensive examination of the energy system in Africa reveals that ensuring a consistent and secure energy supply is a pivotal factor for driving economic growth. Many Sub-Saharan African nations find themselves among the least developed economies globally. A significant portion of the region's population lacks access to electricity and modern energy services, and those who do have access often experience frequent power outages. In 2016, over two-thirds of the Sub-Saharan African population, totaling around 600 million people, were without access to electricity. Additionally, 850 million people lacked access to clean cooking facilities, including options like natural gas, liquefied petroleum gas, electricity, biogas, or improved biomass cook stoves. While not explicitly addressed in this analysis, the limited access to electricity poses challenges to water pumping capabilities, especially during dry periods when groundwater levels are diminished. This limitation has the potential to reduce agricultural production and disrupt the supply of drinking water (Maqbool & Akubo, 2022).

In recent years, strides have been made in enhancing electricity accessibility. The percentage of the population with access to electricity saw an increase from 43% in 2010 to 51% in 2016. Despite this progress, the overall number of individuals without access to clean cooking facilities remained unchanged at 72% during the same period. The absence of access to clean cooking necessitates, in many nations, women spending approximately an hour daily collecting fuelwood and several hours using inefficient stoves for cooking. This situation leads to indoor air pollution, which carries health implications and contributes to premature deaths. In addition, inadequate access to electricity heightens the vulnerability of water supply in diverse settings and can contribute to increased deforestation.

Insufficient access to electricity also affects various facets of life, such as constrained educational opportunities, the unavailability of refrigeration for vaccines, impaired telecommunications leading to restricted communication and commerce. Nonetheless, addressing the energy demands essential for Africa's transformation presents formidable challenges. The existing infrastructure is constrained, compounded by a rapidly growing population. Traditionally, fossil fuels and biomass have been the more accessible energy sources to harness, and the complications of climate change are amplifying development challenges. To meet forthcoming energy requirements, potential strategies involve investing in trade and embracing new technologies to tap into the continent's abundant energy resources.

This study outlines scenarios for the least-cost, low-carbon technology investments. Despite Africa's abundant energy resources, including both fossil fuels and renewable energy, the continent's installed electricity capacity was around 165 GW in 2015. This figure pales in comparison to India's (308 GW), China's (1,519 GW), and South Africa's contribution, constituting roughly one-fourth (47 GW, 2015) of the total capacity in Africa. Numerous African nations have yet to tap into their substantial renewable energy potential, reflected in the modest 19% share of renewables in the power generation mix. Notably, Africa boasts the highest percentage of untapped technical hydropower potential among all continents, with only 11% harnessed to date (International Hydropower Association, 2019).

Despite these energy challenges, Africa's gross economic activity is anticipated to maintain its rapid growth. In Sub-Saharan Africa, the economic growth rate was 2.4% in 2018 (compared to

2.5% in 2017) and is projected to reach 3.5% in 2019 (The World Bank, 2019b). Countries such as Ethiopia, the Democratic Republic of the Congo (DRC), Côte d'Ivoire, Mozambique, Tanzania, and Rwanda are among the fastest-growing economies on the continent (International Monetary Fund, 2019). For instance, Ethiopia recorded a substantial economic growth rate of 7.7% in 2017/18, fueled by mineral extraction, commerce, and agricultural development (Mohan et al., 2019).

2.5 Fixed solar system

A stationary solar power system, commonly referred to as a fixed-tilt or fixed solar system, is a type of solar installation where solar panels are permanently set at a fixed tilt angle and do not actively follow the sun's movement across the sky. Unlike solar tracking systems that adjust the orientation of panels throughout the day, fixed solar power systems maintain a constant position. In this setup, solar panels are installed in a specific location and do not move, remaining stationary to capture sunlight that reaches the cells. While fixed solar power systems are simple and cost-effective, they may not capture as much sunlight as solar tracking systems, particularly during the morning and evening when the sun is not directly overhead. The decision between fixed and tracking systems is influenced by factors such as cost, available space, and the desired level of energy efficiency for a specific application.



Figure 2.2: Fixed Solar system

2.6 Tilt angle

The tilt angle of a solar panel denotes its position relative to the horizontal plane. This parameter holds significance in the design and implementation of solar power systems, as it substantially influences the sunlight exposure and, consequently, the energy output of a solar panel. The optimal tilt angle is contingent upon the geographical location of the solar installation and its intended purpose.

When setting up a solar panel system, a crucial consideration is determining the direction and angle at which the solar panel will be positioned. The solar panel operates most efficiently when accurately oriented towards the sun. Observation reveals variations in the directions and inclinations of solar panels, indicating a lack of information about their alignment and degree of inclination. While directing a solar panel towards the sun may seem straightforward, it is essential to recognize that the sun's position changes in different time zones throughout the year.

Throughout the day, the sun's position undergoes constant changes, underscoring the need to determine an optimal tilt angle for solar panels. The orientation of the solar panel is dictated by the geographical location of the system's installation. In northern hemisphere countries, the solar panel faces south, while in southern hemisphere countries, it points north. By aligning the solar panel with an optimal tilt angle, it maximizes solar power absorption throughout the day. The specific angle is influenced by the location and the time of the year. Calculating the solar panel tilt angle involves considering the latitude value. For latitudes below 25, the angle is obtained by multiplying the latitude by 0.87. If the latitude falls between 25 and 50, the calculation involves multiplying the latitude by 0.87 and adding 3.1 degrees. The resulting inclination angle represents the angle between the solar panel and the ground, with zero degrees indicating complete horizontal positioning and 90 degrees representing full vertical orientation. Determining the latitude value for a location can be easily accomplished using tools like Google Maps.

The solar panel angle refers to the vertical tilt of the solar panels, and understanding it can be a bit complex as the appropriate tilt varies based on geographic location and time of the year. The system's tilt angle is essentially the angle at which it is positioned on the roof or the mounting structure to which it is attached. Ideally, photovoltaic (PV) modules should be tilted at an angle equivalent to the site's latitude. However, practical considerations often come into play, especially when the panels are installed on a roof, causing them to adopt the roof's angle instead. While this

may not always be the most ideal scenario, it is often the most practical and cost-effective, still yielding satisfactory results in many cases. Introducing a tilt frame could enhance performance but typically raises the system's cost, making it a less common choice unless absolutely necessary. In situations where maximizing energy production throughout the day is crucial, such as in off-grid solar PV systems, a tilt frame may be necessary to precisely align the solar panels with the site's latitude.

The output and performance of solar panels will vary based on a lot of factors, including the tilt angle of the solar array. Tilt angle is defined as the number of degrees your array orients from the ground so it can face the sun. An easy method for determining solar panel tilt is to match the latitude of your home. Factors such as roof pitch and time of year can affect the overall efficiency of your arrays. To understand how solar panel angle influences performance, it's helpful to know how a system collects energy. Solar cells those little sections on each panel are made of a special semiconductor material, capable of absorbing radiant energy. However, that semiconductor can only take in a specific wavelength, meaning only a small portion of the light that hits it can be collected. With so few photons able to enter the solar cell, it's critical that they have as direct an entrance as possible. To enable this interaction, it's generally wise to point solar panels perpendicular to the sun's rays. However, unlike direction, tilt angle varies depending on the seasons. Even with the optimal orientation, you can expect your solar panels to experience some efficiency drop depending on the season.

2.7 Solar tracking system

A solar tracking system with time-dependent movement is engineered to dynamically alter the positioning of solar panels or mirrors, enabling them to follow the sun's changing position as it moves across the sky throughout the day and across different seasons. This dynamic movement is synchronized with the Earth's rotation and orbit around the sun. The primary objective of such a system is to optimize the exposure of solar collection surfaces to sunlight, thereby maximizing energy capture and overall system efficiency. The time-based movement in a solar tracking system involves continuously adjusting the orientation of solar panels or collectors based on the time of day. This adaptability ensures that solar panels receive maximum sunlight exposure throughout the day, ultimately improving the overall efficiency of energy capture.

A solar tracker is a mechanism designed to orient an object at an angle relative to the sun. The primary applications of solar trackers involve aligning photovoltaic (PV) panels or solar panels to ensure they stay perpendicular to the Sun's rays and positioning space telescopes to determine the Sun's direction accurately. Photovoltaic solar trackers dynamically adjust the orientation of a solar panel based on the Sun's position in the sky. By maintaining the panel's perpendicular alignment with the Sun, these trackers optimize sunlight absorption, reducing light reflection and enhancing energy absorption. This harvested energy can then be converted into power. The solar tracking process utilizes sophisticated instruments to ascertain the Sun's location relative to the aligned object. These instruments typically comprise computers capable of processing intricate algorithms for effective Sun tracking, and sensors that provide information to a computer about the Sun's position. In certain scenarios, when attached to a solar panel with a simple circuit board, these sensors enable solar tracking without the need for a computer (Gafurov & Chung, 2019).

Research indicates that the orientation of sunlight significantly impacts the power output of solar panels. A solar panel aligned precisely perpendicular to the Sun generates more power compared to a panel positioned at a non-perpendicular angle. The impact on power output is more pronounced at larger angles, with small deviations having a relatively smaller effect. Moreover, the Sun's angle varies both seasonally from north to south and daily from east to west. While east-to-west tracking is crucial, the impact of north-to-south tracking is less pronounced. Solar trackers offer substantial benefits for renewable energy, leading to a potential increase in power output by approximately 30 to 40 percent. This increase holds the promise of expanding markets for solar power. However, solar trackers come with notable drawbacks. Static solar panels may offer warranties spanning decades with minimal maintenance requirements, while solar trackers typically have shorter warranties and necessitate one or more actuators for panel movement. These moving components increase installation costs and reduce reliability. Active tracking systems may also consume a small amount of energy, unlike passive systems that do not require additional energy. Computer-based algorithmic solar trackers are more expensive, demand additional maintenance, and become obsolete faster than static solar panels, primarily due to their reliance on rapidly evolving electronic components that may be challenging to replace within relatively short periods (Jin et al., 2013).

2.8 Types of solar tracking system

The increasing popularity of solar tracking systems is accompanied by a lack of comprehensive understanding regarding the complete advantages and potential drawbacks of these systems. Solar panel tracking solutions represent an advanced technology for mounting photovoltaic panels. Unlike stationary mounts that hold panels in a fixed position, solar trackers are designed to automatically move and follow the sun's trajectory throughout the day, ensuring optimal positioning and maximizing output. There are two primary types of solar tracking systems: the single-axis solar tracking system and the dual-axis solar tracking system (Maiga, 2021).

2.8.1 Single axis Solar tracker

A single-axis solar tracking system operates by adjusting solar panels around a single axis point, effectively tracking the sun's movement along the east and west directions. While it may not capture the absolute maximum energy produced by the solar system, this system ensures that as the sun rises and sets, the panels equipped with single-axis trackers remain relatively perpendicular to the sun, optimizing sunlight absorption. This system is particularly suitable for PV panels installed on flat and even land surfaces, and despite its slightly higher installation cost, it quickly recovers its investment through efficient power generation (Kumbhar et al., 2021).

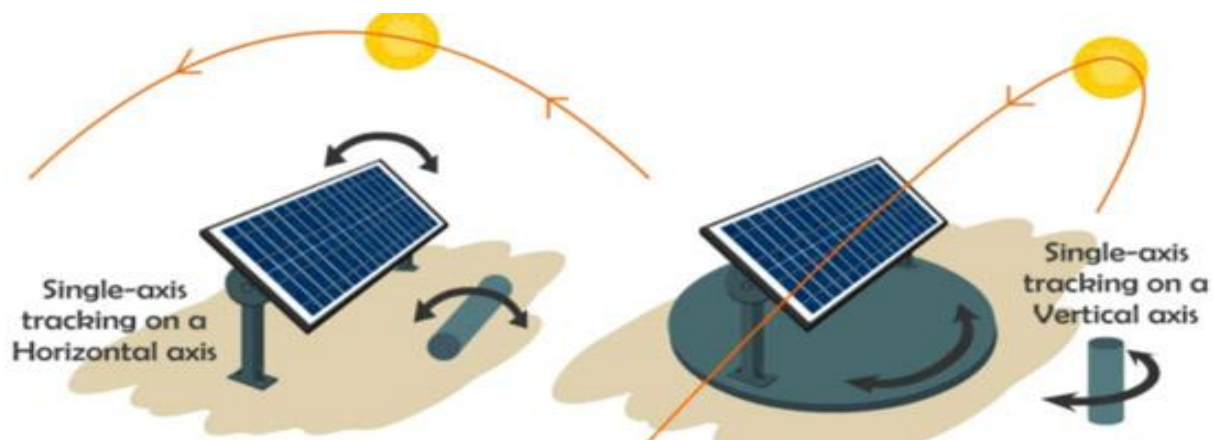

Figure 2.3: Single axis solar tracker

2.8.2 Dual axis solar tracker

A dual axis tracker rotates the solar panels from East to West and north to South to provide direct exposure to sunlight. The presence of two axes in tracker, primary and secondary axis facilitate convenient movement of the solar panels in all directions. The most attractive advantages of this system is that it helps to produce around 40% more than energy produced by fixed solar panel system. As the sun light direction keeps changing throughout the day, it is crucial that the solar panels have a flexible base to remain perpendicular to the sun. Therefore, a dual axis solar tracker has an inbuilt auto-light tracking control system, which facilitates free movement of the panels. The components of solar tracking system such as signal processing units, mechanical and electromagnetic motion controller, power supply, light sensors and PV cells of the solar tracker help in the auto-tracking of the sun.

The solar panels activate after receiving high intensively sunlight. Accordingly, the send signals to the sensors. The sensors carry these signals to the PLC. The PLC of the solar tracker compares the sight intensity and sends information to the rotation motor, which turns the panel towards the sun. The motor of a dual axis solar tracker works by rotating the panels in all four directions for more energy production (Vinodhkumar & John, 2020).

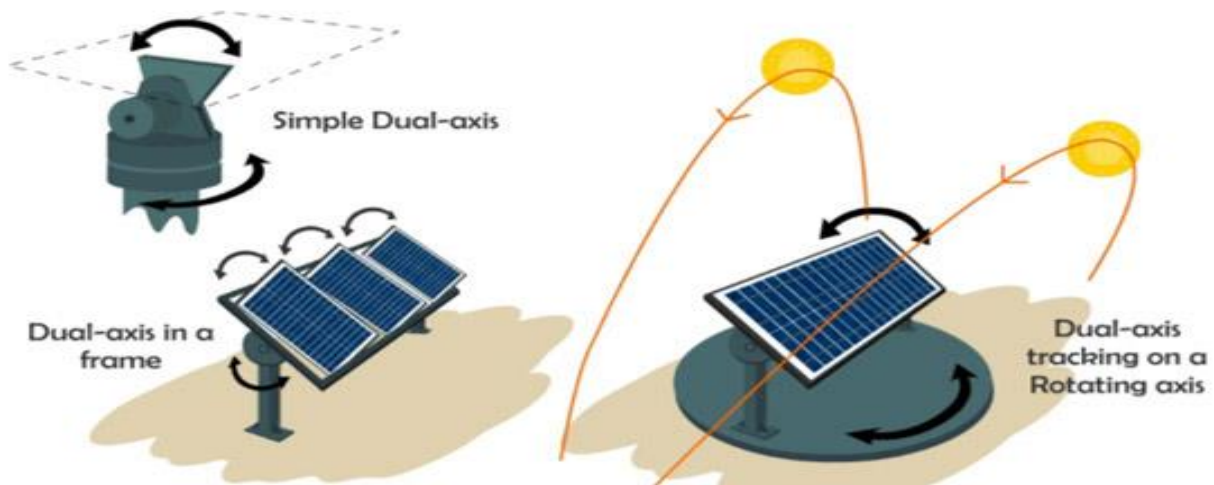

Figure 2.4: Dual axis solar tracker

2.9 Advantages of solar tracking system

Installing a solar tracking system offers significant advantages, primarily in the form of enhanced energy output. Adding a tracker to a panel system has the potential to increase productivity by 10 to 25 percent, depending on the location of the home. In contrast, fixed-angle panels are typically positioned at an angle that maximizes sun exposure throughout the year. However, since the Earth is continually orbiting the sun, the precise optimal angle varies depending on both the time of day and the time of year. With a fixed system, it is possible to address seasonal changes and improve the output of fixed panels by manually adjusting their angle two, three, or four times a year (Lewandoski et al., 2021).

2.10 Related works

Solar energy stands out as the most abundant and widely distributed form of energy available on Earth. Currently, solar photovoltaic (PV) power generation has emerged as the fastest-growing energy technology globally, owing to its maturity and scalability. Predicted to lead power generation technology investments from 2017 to 2040 due to its relatively low cost, PV technology is anticipated to surpass nuclear, wind, and gas generation capacities worldwide. However, achieving further reductions in system-level costs is essential to sustain decreasing costs while adhering to crystalline silicon wafer-based technology, which constitutes 90% of global production and has a maximum energy conversion efficiency of 26%. Despite the potential of emerging technologies to promise lower-cost manufacturing and deployment, none have achieved large-scale commercial production, facing challenges related to PV material scaling limits, manufacturing complexity, and cost. Although crystalline silicon wafer-based technology offers advantages in reducing global environmental impacts, its current limitations include high production costs and lower efficiency compared to alternative sources. The classification scheme for PV technology based on material complexity and energy conversion efficiency is presented in Jin et al., 2013).

The increasing demand for electrical energy has led to the exploration of various power sources in modern power systems. Ongoing research endeavors aim to enhance the efficiency of power systems, and solar tracking systems play a crucial role in these efforts to optimize power sources. The primary objective of solar tracking is to maximize the energy output from solar panels by

ensuring they have the maximum exposure to sunlight. Various techniques have been developed for solar tracking systems, which involve orienting a payload, typically solar panels, toward the sun. This tracking movement is accomplished by integrating a servo motor with the solar panel, ensuring that the panel maintains a constant orientation perpendicular to the sun to generate maximum energy (Hammoumi et al., 2021). This is achieved through a programmed microcontroller that delivers stepper pulses at periodic intervals to the servo motors, enabling the mounted panel to rotate in one direction and then return to the starting point for the next day's sunlight, as desired. In constructing a solar panel, durability is crucial to withstand external elements such as wind, rain, and prolonged exposure to UV radiation. Additionally, the solar panel must be resilient during handling and transportation, and its external fixing features need to be robust and reliable for easy mounting onto a roof or other systems.

As per Lin (2015), the typical power output of most solar panels ranges between 200 to 350 watts per panel, a value contingent upon the panel's actual size and the specific technology employed, such as monocrystalline or polycrystalline. Devices that derive energy from sustainable sources fall under the category of renewable energy. These sources include solar, geothermal, hydroelectricity, wind, tide/wave/ocean, biofuels, and municipal waste. The emergence of these energy alternatives is driven by global concerns for sustainability, prompted by issues like global warming, pollution, climate change, depletion of natural resources, and the escalating demand for energy consumption (Alharthi et al., 2018).

2.10 Contribution of researcher

The contribution that the researcher made here is to satisfy existing gaps by developing and integrating advanced sensor technologies and smart algorithms that facilitate real-time data-driven tracking in solar tracking systems reliant on mechanical rotation and present timing. As such, the research aims to design robust light sensor systems that can capture sunlight variations with high accuracy and integrate IoT technologies to make intelligent control systems. These would dynamically orient solar panels in a way that enables them to function at peak efficiency while reacting to weather changes and minimizing energy use. This research would provide automatic designs that make them stronger, low-maintenance, and enhance general reliability and lifespan, hence rendering the tracking systems more effective, cost-effective, and adaptable for solar energy.

2.11 Gaps found in existing researches

There is a relay on existing solar tracking systems, which are mechanical and rotational, with timing schedules rather than by real-time data from sensors. They present important gaps and limitations. First, and most importantly, time-based mechanical tracking is unable to respond to real-time environmental conditions. These systems cannot react to the change of sunlight in suboptimal alignment to the sun and reduce energy efficiency. In addition, the mechanical parts are subjected to wear and tear, increasing the maintenance costs and chances of system breakdown. In part, this might also include greater energy use for running the mechanical parts involved, some of which nets out the energy gain from the solar panels.

Moreover, mechanical time-based tracking systems do not account for changes in the path of the sun resulting from earth's tilt and orbital eccentricity. This might make them track less precisely and therefore be less efficient overall than those types of systems that work based on real-time light data from sensors. These light sensors dynamically reorient the panels to get maximum sunlight, which allows them to perform better and yield more energy. By their very nature, mechanical time-based systems are inherently less flexible and capable of adaptation in the absence of response ability to real-time conditions, much affecting their effectiveness in maximizing solar energy capture and hence their overall return on investment. Integrating real-time data into more sophisticated tracking algorithms will, therefore, be important to address these gaps and limitations.

CPAPTER 3: METHODOLOGY

3.1 Introduction

This chapter explains methods, which have been used to correct information during research and software tools. The satisfactory results obtained are motivated by the good choice of methods and techniques used for collecting data. In this chapter we are going to clarify methods and techniques that we have used in order to reach to the objectives of our project. The achievement of the objectives of any research project, researchers should often research through in a particular methodology. And methodologies are different depending on the objectives for achievement and the need of the society and the whole world in general. Whereby a researcher is focusing on, but it is better to link the project with the society need by trying to do our best. Discussion looking how this research project could be processed successfully. The time and our ability to do research conducts us to use the survey research, so the information, interviews, ideas of different people and data had all collected and informed on telephone communication.

We sought information from various sources, including library books, electronic resources on the internet, and reports from other researchers during the preliminary stages of this research. Additionally, consultations were conducted with different individuals to gather their insights and engage in discussions on how to successfully progress with the research project. This chapter provides details on the materials and methods employed in the study. The initial section outlines the high-level system architecture, followed by an in-depth discussion of the embedded system-level design. This design encompasses the system block diagram, components from the Original Equipment Manufacturer (OEM), descriptions in the system Program Description Language (PDLs), use case diagrams, and system flow charts. The proposal of a rapid edge AI prototyping pipeline is also presented. Finally, the chapter concludes with the modeling and layout of the embedded system.

3.2 System block diagram

A system block diagram is a graphical representation of a system or process that shows the major components or subsystems and their interconnections. It is a commonly used tool in engineering, control systems, and various other fields to help understand and communicate how a complex

system works. Block diagrams typically use blocks to represent individual components or functions and lines/arrows to represent the flow of information, signals, or materials between these components.

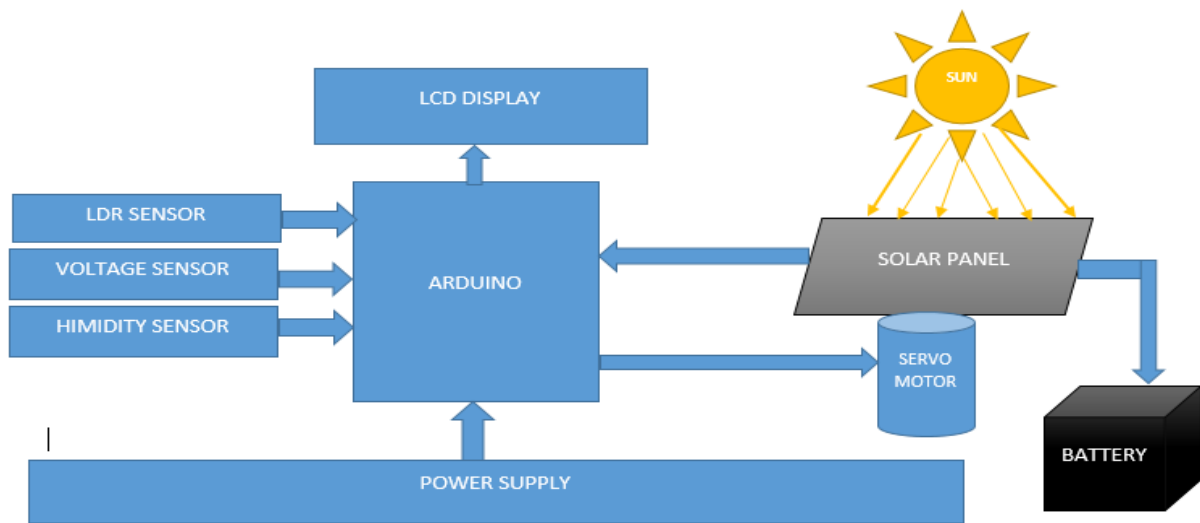

Figure 3.1: System block diagram

3.3 Hardware components

A solar tracking system is designed to adjust the orientation of solar panels to maximize exposure to sunlight throughout the day. The hardware components of a solar tracking system can vary based on the tracking strategy single-axis or dual-axis, the scale of the installation, and the technology used. The specific components and their configurations can vary between different manufacturers and technologies. It's essential to choose a solar tracking system that aligns with the specific requirements of the solar installation and environmental conditions at the site.

Table 3.1 Hardware components

#	Device	Specification	Role
1	Solar Panels	Power Output: 50W - 200W Efficiency: 15% - 20%	Converts sunlight into electrical energy (voltage).
2	Light Dependent Resistors (LDRs)	Sensitivity: 500 - 10,000 lux Resistance Range: 1k Ω - 100k Ω	Detects light intensity to guide the solar panel's orientation.
3	Microcontroller	Model: Arduino Uno Processor: 16 MHz Memory: 32KB Flash	Processes sensor data and controls the solar panel's movement.
4	Servo Motor	Torque: 2.5kg/cm Operating Voltage: 4.8V - 6V	Physically rotates the solar panel to align with sunlight.
5	Battery	Capacity: 12V, 100Ah Type: Lead-acid or Lithium-ion	Stores electrical energy generated by the solar panels.
6	Power Supply Unit	Output: 5V/12V Power: 10W - 50W	Distributes power to system components and ensures proper operation.
7	LCD Display	Size: 16x2 or 20x4 characters Interface: I2C or Parallel	Displays real-time data such as voltage, battery level, and light intensity.
8	Humidity Sensor	Range: 20% - 90% RH Accuracy: \pm 5% RH	Monitors environmental humidity to assess its impact on solar efficiency.

3.4 System development methodology

The software development methodology is a process or series of processes used in software development. Again, quite broad but that it is things like a design phase, a development phase. It is ways of thinking about things like waterfall being a non-iterative kind of process. Generally, it takes the form of defined phases.

Agile methodology relies on an iterative and continuous process that fosters flexibility, experimentation, and adaptability. This approach involves cross-functional teams working on successive iterations of a product, which are organized and prioritized according to the evolving requirements of the customer. Business stakeholders and developers collaborate closely to develop a product that aligns with both customer needs and company objectives. Agile integrates all components of a project to create a comprehensive and effective product. While there are six phases in the agile approach, these stages are flexible and often evolve as the product changes. The phases may overlap, and multiple stages of the process can occur concurrently. The initial phase involves Requirements Analysis, where projects are envisioned, defined, and prioritized based on user needs and company goals.

In the Planning phase, teams are established, funding is allocated, and initial requirements are discussed and formulated. These initial requirements are subject to change as the process unfolds. The Design phase involves development teams working to deliver software based on the defined requirements and feedback. Multiple teams collaborate on the iterations of development, communicating progress at each step. During the Implementation or coding phase, activities such as Quality Assurance (QA) testing, documentation development, internal and external training, and the final release of the iteration are carried out. Testing continues in the subsequent phase, where teams create, troubleshoot, and support the software product as it progresses. In the Deployment phase, the product is delivered to customers for their use. Considerations include customer notifications, migrations, and end-of-life activities for the product. These six phases of the agile approach emphasize collaboration, adaptability, and continuous improvement throughout the software development process.

3.5 Data collection technique

Data collection methods refer to the techniques and procedures employed to gather information for research purposes. These methods can vary from straightforward self-reported surveys to more intricate experiments and may involve either quantitative or qualitative approaches to data collection. In this study, primary data will be utilized, collected through a specially designed system. Initially, a solar tracking fixed system was developed and used to capture data on two different days. The collected data included solar energy voltages captured by the solar panel.

Subsequently, a servo motor was integrated into the system to enable rotation. The rotating system was then employed to gather data on solar energy captured on two different days.

3.6 System requirements

This system operates on various editions of the Arduino IDE and supports multiple programming languages such as C, C++, Python, Java, among others. Additionally, it is compatible with different operating systems such as Linux, Android, Windows, and macOS. Furthermore, the system adapts to the screen size of the device it runs on.

3.7 Tools and languages

This study was crafted utilizing a variety of tools, which were categorized into two groups along with various frameworks. In the realm of software development, software tools and programming languages play crucial roles. These components empower developers to design, test, and uphold software applications.

3.7.1 Arduino IDE

The Arduino Integrated Development Environment (IDE) serves as a software application employed in the programming and creation of applications for Arduino microcontroller boards. Arduino boards, renowned as open-source hardware platforms, find extensive application in diverse electronics and do-it-yourself (DIY) projects. The Arduino IDE, also known as Arduino Software (IDE), encompasses a text editor for code composition, a message area, a text console, a toolbar featuring common function buttons, and a set of menus. Its functionality includes linking with Arduino hardware for program uploads and communication with the connected devices.

3.8 Data analysis

Data analysis is the process of inspecting, cleaning, transforming, and interpreting data to discover useful information, draw conclusions, and support decision-making. Data analysis is the process of inspecting, cleaning, transforming, and modeling data to discover useful information, draw conclusions, and support decision-making. It is a crucial step in extracting insights and knowledge from datasets in various fields, including business, science, healthcare, and more.

Python, being an object-oriented programming language, incorporates diverse libraries and tools that can simplify the tasks involved in Data Analysis. Presently, the association between Data Analytics and Python is indistinguishable. The widespread recognition that Python has gained in the realms of Data Science and Data Analytics is attributed to its substantial adaptability and functionality. In this study, python programming is used as data analysis tool to produce graphs that compare the productivity of both fixed and rotating solar tracking system. Python programming is a popular tool uses in data analysis. In this study, python was used to analyze data captured by both solar panel systems to generate graphs that show variations and differences of both systems.

3.9 System functionality

Rotating solar panels based on light intensity rather than fixed schedule significantly increases the amount of energy captured, wherein the solar panels rotate with light intensities instead of a pre-programmed basis. Under this strategy, light-dependent sensors such as Light Dependent Resistors, or LDRs, continually monitor the intensity of sunlight coming from all directions. With that, the solar panel is dynamically adjusted to the direction where the light is most intense. It ensures that the panel is kept oriented for optimal reception always with the sun, since its position in the sky changes throughout the day or with changing atmospheric conditions. Unlike time-based rotation, which is based on an assumed regular and predictable path of the sun, which takes no account of clouds or other obstructions, light intensity-based rotation responds in real time to the actual availability of sunlight, maximizing energy capture in variable conditions.

This would call for a microcontroller to process the input from a couple of LDR sensors set around the panel. It determines the direction with the highest light intensity and drives a servo motor to adjust the angle of the panel. The feedback loop in real-time allows the panel to adapt to changes in light immediately, such as those experienced during the partially cloudy periods of the sun or during different periods of the day when the position of the sun changes because of the rotation of Earth. The method works because it keeps the panel always oriented to receive as much of the sun's rays as possible, increasing overall efficiency and energy output from the solar system, making it superior to rotation based on time, which may not be as responsive to changes in the environment.

CHAPTER 4: SYSTEM ANALYSIS AND DESIGN

4.1 Introduction

This chapter shows the results and finding obtained during implementation of Design and implementation of rotating IoT based sunlight trucking system and comparative study between fixed and rotating sunlight system in terms of voltage generating. The project is elucidated by addressing limitations encountered during the prototype implementation and presenting the findings obtained from the results. It encompasses discussions on design, implementation, and hardware connectivity. Engineering designs are typically categorized as inventions, involving the creation or enhancement of devices and systems through human effort. Inventions or designs do not spontaneously emerge; rather, they result from the integration of technologies to fulfill human needs or resolve issues. Digital tools have played a crucial role in facilitating designers to communicate, visualize, and analyze ideas in a manner that would have been considerably more challenging in the past. Consequently, a design arises from an individual's endeavor to accomplish a task more expeditiously or effectively. During the development of this system, due consideration was given to economic factors that the project would address. Numerous systems may perform similar tasks, but the distinguishing factor lies in how efficiently they resolve operational issues and their cost-effectiveness.

4.2 Data flow diagram

A Data Flow Diagram (DFD) acronym illustrates the flow of data within a system or process, providing insights into the inputs and outputs of each entity and the process itself. DFDs lack control flow and do not incorporate loops or decision rules. Flowcharts can be utilized to articulate specific operations based on the type of data. This graphical tool is valuable for communication with users, managers, and other stakeholders, facilitating the analysis of both existing and proposed systems.

The primary light sensors in this project are Light Dependent Resistors (LDRs). Two servo motors are affixed to the structure supporting the solar panel, and the Arduino program is uploaded to the microcontroller. The project operates as follows: LDRs detect the sunlight falling on them, with two LDRs divided into left and right for east to west tracking. The analog values from the top and

bottom LDRs are compared, and if the top set receives more light, the vertical servo moves in that direction. In the event that the lower Light Dependent Resistors (LDRs) detect a higher intensity of light, the servo adjusts in that particular direction. To achieve angular deflection of the solar panel, the analog values from the two left LDRs and the two right LDRs are assessed. If the left set of LDRs receives more light than the right set, the horizontal servo responds by moving in the left direction. Conversely, if the right set of LDRs registers more light, the servo adjusts in the right direction.

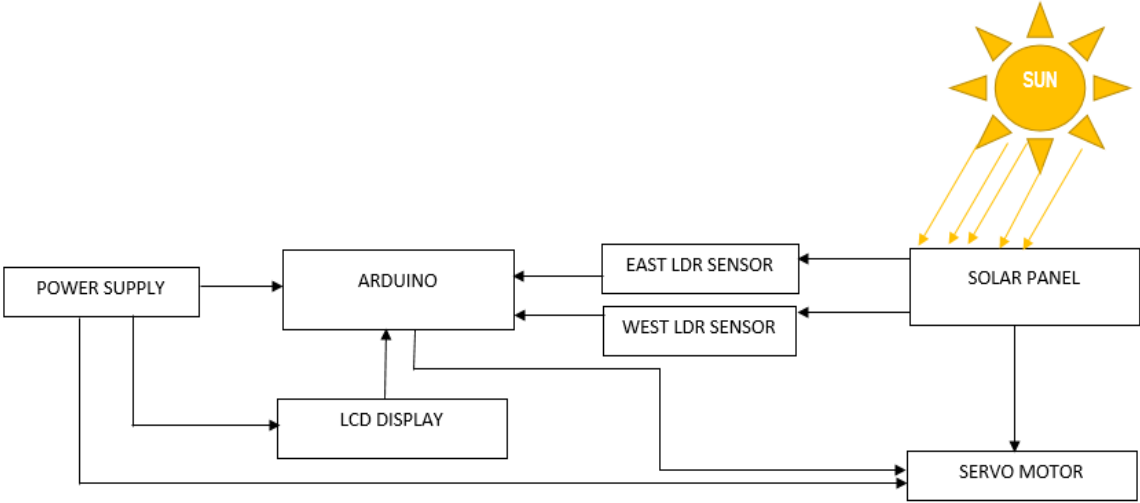

Figure 4.1: Data flow diagram

4.3 System design in Proteus

Figure 21 illustrates the system design within the Proteus software, showcasing essential components such as Arduino Uno, board, solar panel, battery, sensors, and LCD. This Proteus diagram provides a visual representation of how hardware devices will be interconnected during the hardware connectivity phase. In the context of designing distributed systems, System Design stands as a fundamental concept. It involves the creation of an architecture for various components, interfaces, and modules within the system, along with the provision of pertinent data that aids in implementing these elements effectively.

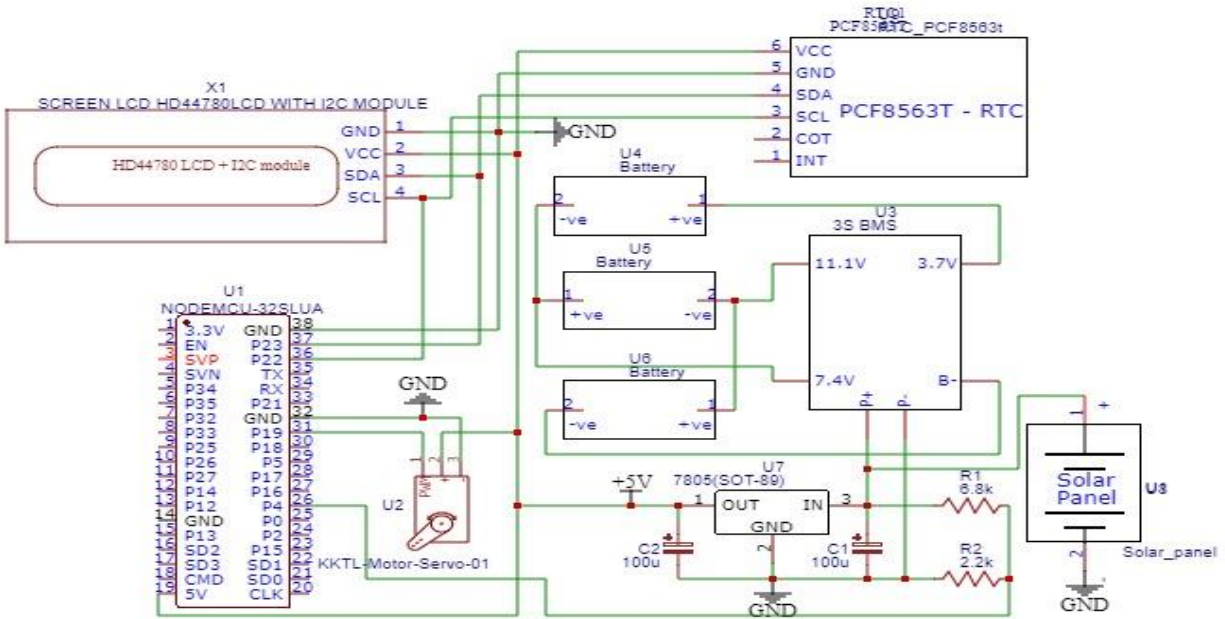

Figure 4.2: Project System design in proteus software

4.4 Hardware connectivity

The main objective this research was to do a design and implementation of rotating IoT based sunlight tracking system and comparative study between fixed and rotating sunlight system in terms of voltage generating. LDRs sense the amount of sunlight falling on them. Two LDRs are divided into left and right. For east–west tracking, the analog values from two top LDRs and two bottom LDRs are compared and if the top set of LDRs receive more light, Single-axis solar tracking systems follow the solar by moving in a single axis vertical or horizontal. Generally, the inclination angle is adjusted manually at certain intervals during the day and automatic movement is provided in the east–west direction. Single-axis systems are more cost-effective than two-axis systems but have lower yields in terms of efficiency. Single-axis solar tracking systems are moved on the vertical or horizontal axis depending on the solar trajectory and the weather condition.



Figure 4.3: Hardware connectivity

4.5 Data gathering

In this research on design and implementation of rotating IoT based sunlight tracking system and comparative study between fixed and rotating sunlight system in terms of voltage generating primary data will be corrected. The project will be designed in two phases, first phase is design and implementation of fixed solar tracking system. Within this phase, researcher uses this fixed tracking system to collect primary data. Data collected are voltages generated by the system during life time of the day. System shows how much voltages the system can tracking during the day. The second phase of the project is to design rotating solar tracking system, with this rotating solar tracking system, researcher uses this system to collect primary data of voltage generated by the system during the day hours when it tracks the movement of the sun from sunset to sun rises time. Both set of data collected using two systems are to be processed in order to see the result in terms of voltage generation comparison.

The complete system consists of solar PV panel, PWM charger controller, battery, and sensor controller with servo motor to turn around solar position. The testing is conducted for two consecutive days. Each day has different time due to unpredictable weather. The project is tested within 8hours, put under direct sunlight to gain as optimum as it can. The performance is then monitored through Blynk application. The reading of actual testing with Blynk is almost the same. The testing is done after near afternoon when the sun almost at the top. The data collection work start around 11 am, finish before 4 pm. The solar tracker also detects the highest intensity through

LDR and give its optimum value. Its rotate according to the sensing of LDR that gives signal to servo motor. Due to unpredictable weather, this experiment only conducted for 8am and 4pm, repeatedly.

4.6 Data collected by fixed and rotating system from 6am to 9am

Table 4.1 shows the voltage generated by the system with fixed solar system from 6am to 9am while table 4.2 shows data captured by rotating system in the same range of time. As mentioned, the test has conducted within same range of time. The time taken was 3 hours starting from 6 am to 9am, it was observed that data collected by both systems are not the same due to the rotating system was able to adjust in the direction where light intensity was high which resulted in capturing high voltages than fixed one.

Table 4. 1: Data captured by fixed solar system from 6am to 9am

Light intensity	Voltages
57Lux	4
57Lux	4
57Lux	4
57Lux	4
57Lux	4
57Lux	4
116Lux	7
116Lux	7
118Lux	7
118Lux	7
118Lux	7
118Lux	7
120Lux	8
120Lux	8
120Lux	8
121Lux	8
136Lux	9
138Lux	9
140Lux	9
142Lux	9
148Lux	10

Table 4. 2: Data captured by rotating solar system from 6am to 9 am

Light intensity	Voltages
82Lux	6
82Lux	6
82Lux	6
82Lux	6
146Lux	9
146Lux	9
146Lux	9
146Lux	9
146Lux	9
146Lux	9
148Lux	9
152Lux	10
152Lux	10
152Lux	10
152Lux	10
156Lux	11
156Lux	11
156Lux	11
156Lux	11
156Lux	11
156Lux	11
162Lux	12

151Lux	11
154Lux	11
167Lux	12
167Lux	12
167Lux	12
167Lux	12
171Lux	12
179ux	13
184Lux	13
184Lux	13
184Lux	13
184Lux	13
186Lux	13
186Lux	14
186Lux	14
186Lux	14
188Lux	14
190Lux	14
194Lux	14
196Lux	14
199Lux	14
204Lux	15
207Lux	15
211Lux	15

164Lux	12
164Lux	12
168Lux	12
171Lux	13
171Lux	13
174Lux	14
176Lux	14
176Lux	14
146Lux	9
147Lux	9
147Lux	9
147Lux	9
147Lux	9
174Lux	14
178Lux	14
180Lux	15
182Lux	16
188Lux	17
189Lux	17
192Lux	17
194Lux	18
196Lux	19
199Lux	19
222Lux	19

The voltage output of the fixed solar system varies from 4 to 15 volts directly, proportionally to the measured light intensity, ranging from 57 Lux to 211 Lux. While on the other hand the voltage output of the rotating solar system varies from 6 to 19 volts directly, proportionally to the measured light intensity, ranging from 82 Lux to 222 Lux.

4.7 Data collected by fixed and rotating system from 9am to 12am

Table 4.3 shows the voltage generated by the system with fixed solar system from 9am to 12am while table 4.4 shows data captured by rotating system in the same range of time. As mentioned, the test has conducted within same range of time. The time taken was 3 hours starting from 9 am to 12pm, it was observed that data collected by both systems are not the same due to the rotating

system was able to adjust in the direction where light intensity was high which resulted in capturing high voltages than fixed one.

Table 4. 3: Data captured by fixed solar System from 9am to 12am

Light intensity	Voltages for fixed system from 9am to 12am
214Lux	15
214Lux	15
215Lux	16
215Lux	17
216Lux	17
216Lux	17
216Lux	17
216Lux	17
217Lux	18
214Lux	14
214Lux	14
214Lux	14
217Lux	18
217Lux	18
218Lux	18
218Lux	18
219Lux	19
219Lux	19
216Lux	17
216Lux	17
216Lux	17
216Lux	17
220Lux	19
220Lux	19
222Lux	20
222Lux	20
222Lux	20
223Lux	21
223Lux	21
219Lux	19
219Lux	19

Table 4. 4: Data captured by rotating solar System from 9am to 12am

Light intensity	Voltages for rotating system from 9 am to 12am
308Lux	26
308Lux	26
308Lux	26
310Lux	27
310Lux	27
310Lux	27
312Lux	27
312Lux	27
312Lux	27
312Lux	24
315Lux	29
315Lux	29
315Lux	29
317Lux	30
319Lux	30
319Lux	30
319Lux	30
323Lux	31
323Lux	31
323Lux	31
306Lux	24
306Lux	24
306Lux	24
306Lux	24
312Lux	27
312Lux	27
329Lux	32
329Lux	32
329Lux	32
329Lux	32
331Lux	34

219Lux	19
224Lux	21
224Lux	21
225Lux	22
225Lux	22
225Lux	22
226Lux	22
226Lux	22
226Lux	22
226Lux	22
227Lux	23
227Lux	23
227Lux	23
227Lux	23

331Lux	34
332Lux	34
332Lux	34
332Lux	34
332Lux	34
333Lux	34
333Lux	34
333Lux	34
334Lux	34
334Lux	34
336Lux	36
336Lux	36
336Lux	36
336Lux	36

The voltage output of the fixed solar system varies from 15 to 23 volts directly, proportionally to the measured light intensity, ranging from 214 Lux to 227 Lux. While on the other hand the voltage output of the rotating solar system varies from 26 to 36 volts directly, proportionally to the measured light intensity, ranging from 308 Lux to 336 Lux.

4.8 Data collected by fixed and rotating system from 12am to 3pm

Table 4.5 shows the voltage generated by the system with fixed solar system from 12am to 3pm while table 4.6 shows data captured by rotating system in the same range of time. As mentioned, the test has conducted within same range of time. The time taken was 3 hours starting from 12 am to 3pm, it was observed that data collected by both systems are not the same due to the rotating system was able to adjust in the direction where light intensity was high which resulted in capturing high voltages than fixed one.

Table 4. 5: Data captured by fixed solar System from 12am to 3pm

Light intensity	Voltages for fixed system from 12am to 3pm
336Lux	36
336Lux	36
336Lux	36
336Lux	36

Table 4. 6: Data captured by rotating solar System from 12am to 12pm

Light intensity	Voltages for rotating system from 12am to 3pm
346Lux	38
346Lux	38
346Lux	38
346Lux	38

340Lux	37
346Lux	37
346Lux	37
348Lux	37
352Lux	38
352Lux	38
352Lux	38
354Lux	38
358Lux	39
362Lux	40
369Lux	40
370Lux	41
372Lux	41
377Lux	41
380Lux	42
382Lux	43
389Lux	44
390Lux	44
392Lux	44
394Lux	44
394Lux	44
396Lux	45
399Lux	45
402Lux	48
402Lux	48
389Lux	45
382Lux	43
384Lux	43
382Lux	43
380Lux	42
378Lux	42
372Lux	42
369Lux	45
359Lux	40
355Lux	39
350Lux	38
346Lux	37
340Lux	37
333Lux	34

348Lux	39
348Lux	39
349Lux	39
351Lux	39
352Lux	39
352Lux	41
352Lux	41
354Lux	41
358Lux	43
362Lux	43
369Lux	44
370Lux	44
372Lux	44
377Lux	45
380Lux	46
382Lux	46
389Lux	47
390Lux	47
392Lux	47
394Lux	47
394Lux	47
396Lux	47
399Lux	48
402Lux	48
402Lux	48
406Lux	51
406Lux	51
406Lux	51
404Lux	49
403Lux	49
403Lux	49
400Lux	48
400Lux	48
400Lux	48
399Lux	48
398Lux	48
394Lux	47
394Lux	47
392Lux	46

333Lux	34
333Lux	34

392Lux	46
392Lux	46

The voltage output of the fixed solar system varies from 36 to 34 volts directly, proportionally to the measured light intensity, ranging from 336 Lux to 333 Lux. While on the other hand the voltage output of the rotating solar system varies from 26 to 36 volts directly, proportionally to the measured light intensity, ranging from 346 Lux to 392 Lux.

4.9 Data collected by fixed and rotating system from 3pm to 6m

Table 4.7 shows the voltage generated by the system with fixed solar system from 3pm to 6pm while table 4.8 shows data captured by rotating system in the same range of time. As mentioned, the test has conducted within same range of time. The time taken was 3 hours starting from 3pm to 6pm, it was observed that data collected by both systems are not the same due to the rotating system was able to adjust in the direction where light intensity was high which resulted in capturing high voltages than fixed one.

Table 4. 7: Data captured by fixed solar System from 3pm to 6pm

Light intensity	Voltages for fixed system from 12am to 3pm
333Lux	34
333Lux	34
333Lux	34
331Lux	32
328Lux	32
328Lux	32
328Lux	32
327Lux	32
327Lux	30
326Lux	30
322Lux	29
322Lux	29
319Lux	27
312Lux	26

Table 4. 8: Data captured by rotating solar System from 3pm to 6pm

Light intensity	Voltages for fixed system from 3pm to 6pm
392Lux	46
392Lux	46
392Lux	46
382Lux	44
382Lux	44
382Lux	44
382Lux	44
379Lux	42
377Lux	42
369Lux	41
361Lux	40
359Lux	40
348Lux	39
348Lux	39

307Lux	25
302Lux	23
298Lux	21
291Lux	21
286Lux	20
281Lux	20
277Lux	20
277Lux	20
274Lux	19
268Lux	18
219Lux	15
219Lux	15
219Lux	15
219Lux	15
216Lux	15
216Lux	15
211Lux	15
209Lux	14
198Lux	14
196Lux	14
172Lux	14
172Lux	14
169Lux	13
159Lux	12
155Lux	12
150Lux	12
146Lux	11
140Lux	10
133Lux	9
133Lux	9
133Lux	9

341Lux	38
341Lux	38
340Lux	38
340Lux	38
340Lux	38
338Lux	38
334Lux	36
330Lux	35
327Lux	34
322Lux	33
319Lux	30
317Lux	28
312Lux	27
308Lux	26
304Lux	26
299Lux	24
294Lux	23
290Lux	23
286Lux	22
279Lux	21
272Lux	21
272Lux	21
269Lux	20
259Lux	19
255Lux	18
250Lux	17
246Lux	16
240Lux	15
233Lux	13
233Lux	13
233Lux	13

The voltage output of the fixed solar system varies from 34 to 9 volts directly, proportionally to the measured light intensity, ranging from 333 Lux to 133 Lux. While on the other hand the voltage output of the rotating solar system varies from 46 to 13 volts directly, proportionally to the measured light intensity, ranging from 392 Lux to 233 Lux.

CHAPTER 5: RESULTS AND ANALYSIS

This chapter presents the results and analysis of findings obtained during implementation of during implementation of design and implementation of rotating IoT based sunlight tracking system and comparative study between fixed and rotating sunlight system in terms of voltage generating. According to the limitation that were encountered during the implementation within the prototype implementation and the results findings gained. The project is explained in terms of hardware connectivity, design and implementation. After project implementation, this chapters shows the result found and the analysis of the results.

5.1 Result and analysis

The results of this research are based the objectives of the research. The objectives of this research are as follow; the first objective of this research is to develop an IoT based solar tracking system and compare voltages generating between fixed and rotating IoT based sunlight tracking system for efficient performance to maximize sunlight absorbed by solar panel system during daytime. The second objective is to develop a tracking system that controls and monitors the movement of solar panel based on the intensity of light along time of the day. The third objective is display voltages generated by both systems over time. The last objective is to make comparison between voltages generated by solar tacking system and fixed solar system.

5.1.1 Rotating solar tracking system

The first objective of this research is to develop an IoT based solar tracking system that moves following the movement of the sun light for efficient performance to maximize sunlight absorbed by solar panel system during daytime. As shown in figure 23 solar rotating system has developed and it is working as it was expected.

5.1.2 Data display on LCD

To display data of voltages captured by solar panel was the second objective of this research. Figure 24 shows the values of data from solar panel. Values change depend the intensity of the sunlight or depend on the weather conditions. With fixed solar tracking system, number of voltages increase when sun is perpendicular to the surface of solar panel where solar panel is exploiting the

maximum of solar energy from the sun. Whereas on rotating solar tracking system, numbers of voltages captured by solar panel are high during all hours of the day sue to the system is able to follow the position of the sun and that allows solar panel to get the maximum of the energy from the sun.



Figure 5.1: Data display on LCD

5.1.3 Voltages of fixed system over light intensity

The second objective of this study was to produce a graphic representation of how fixed solar tracking system produces voltages dependent on the position of solar panel and sun. The graphic produced by data analysis shows that there is variation of voltages captured by fixed solar system across the day. Results show that solar panel captures less solar energy during morning hours because of weak light intensity of the sun and due to the position of solar surface on the sun light position and because the weakness of solar intensity in morning hours. For fixed solar system, the more there is small angle between sunlight and solar panel surface, the less energy capture by the solar panel.

5.1.4 Statistical analysis fixed Solar system from 6am to 9am

As data have captured during the day, data have analyzed statistically to get the mean. To calculate the mean of voltages captured during the day by fixed solar systems, we sum all the data points recorded during these hours and divide number of hours. Let say that data points are $x_1, x_2, x_3 + \dots x_{45}$

Mathematically, this expressed as Mean = $\frac{x_1+x_2+x_3+\dots+x_{45}}{n}$

$$\sum_i^n xi=621$$

$$X = \sum_i^n \frac{xi}{n} = \frac{621}{45}$$

$$X=10.24v$$

The average of the data captured by the fixed solar system calculations is 10.24v. This means that for the period of measurement, all the recorded voltage values added and then divided by the number of measurements gave an average voltage of 10.24Volts. This value gives a benchmark of the typical performance level of the solar system within the given period and thus helps in assessing how efficient and consistent the voltage generation by the system has been.

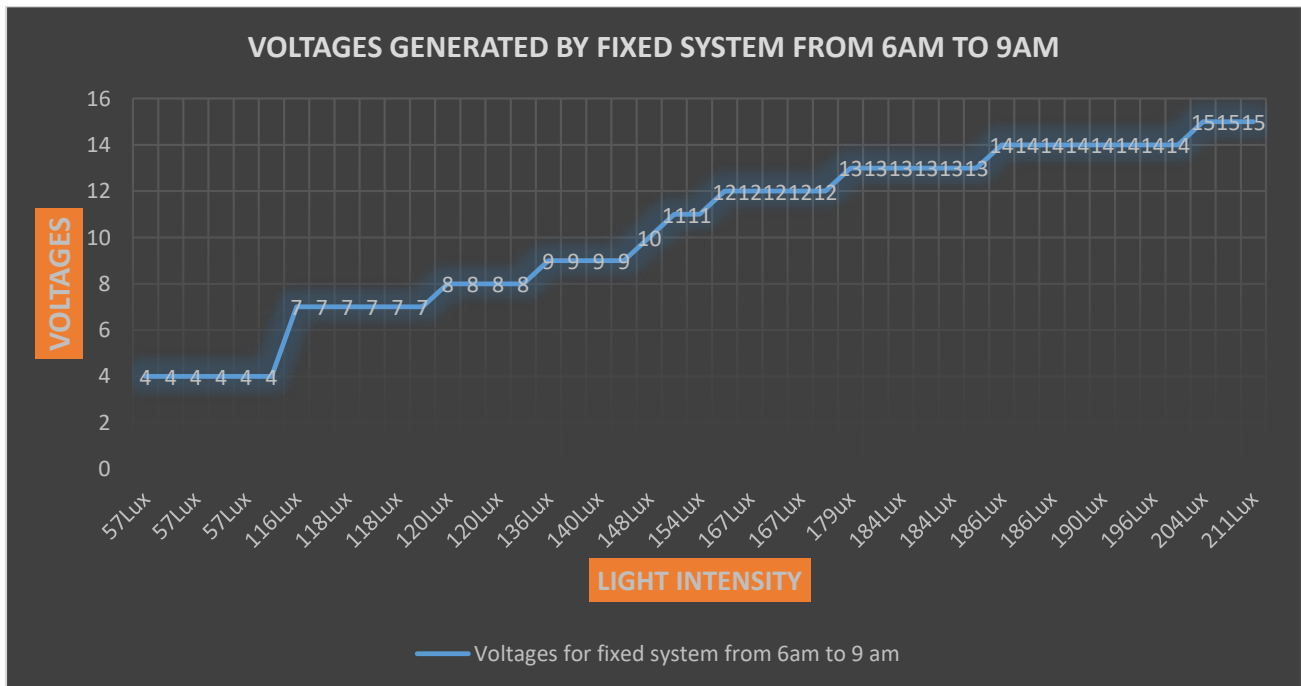

Figure 5.2: Voltages generated by fixed solar system from 6am to 9am

The figure 5.2 indicates changes in data captured by a fixed solar system over time. This graph presentation gives an easy way of establishing how the performance of the solar system changes

upon division by the number of measurements returned an average voltage of 11.73Volts. This average value gives a pointer into the general performance level for the solar system over this period; thus, it sets a very important benchmark in assessing its efficiency and consistency in voltage generation.

Voltages Comparison

The voltage produced is compared between the static and revolving solar systems from 6 am to 9 am. Both systems had registered low voltage output due to weak solar light intensity during morning hours. For the fixed solar system, the average generated voltage is 10.24 V, while that of the rotating system stands at an average high of 11.73 V for the same period, considering it adjusts its position all the time to efficiently get sunlight. From the average ΔV above, the voltage output difference between the two systems amounts to 1.49 V, proving the superiority of the rotating system in maximizing the incoming radiation despite the limited availability of light in the morning. This difference underlines that, even in less favorable conditions, a rotating system can catch more energy; though both systems were handicapped by the low intensity of morning sunlight.

5.1.4 Statistical analysis fixed Solar system from 9am to 12am

As data have captured during the day, data have analyzed statistically to get the mean. To calculate the mean of voltages captured during the day by fixed solar systems, we sum all the data points recorded during these hours and divide number of hours. Let say that data points are $x_1, x_2, x_3 + \dots x_{45}$

Mathematically, this expressed as $\text{Mean} = \frac{x_1+x_2+x_3+\dots+x_{45}}{n}$

$$\sum_i^n xi=845$$

$$X = \sum_i^n \frac{xi}{n} = \frac{854}{45}$$

$$X=18.97v$$

The average of the data captured by the fixed solar system from 9am to 12am is 18.97v. This means that for the period of measurement, all the recorded voltage values added and then divided

by the number of measurements gave an average voltage of 18.97Volts. This value gives a benchmark of the typical performance level of the solar system within the given period and thus helps in assessing how efficient and consistent the voltage generation by the system has been.

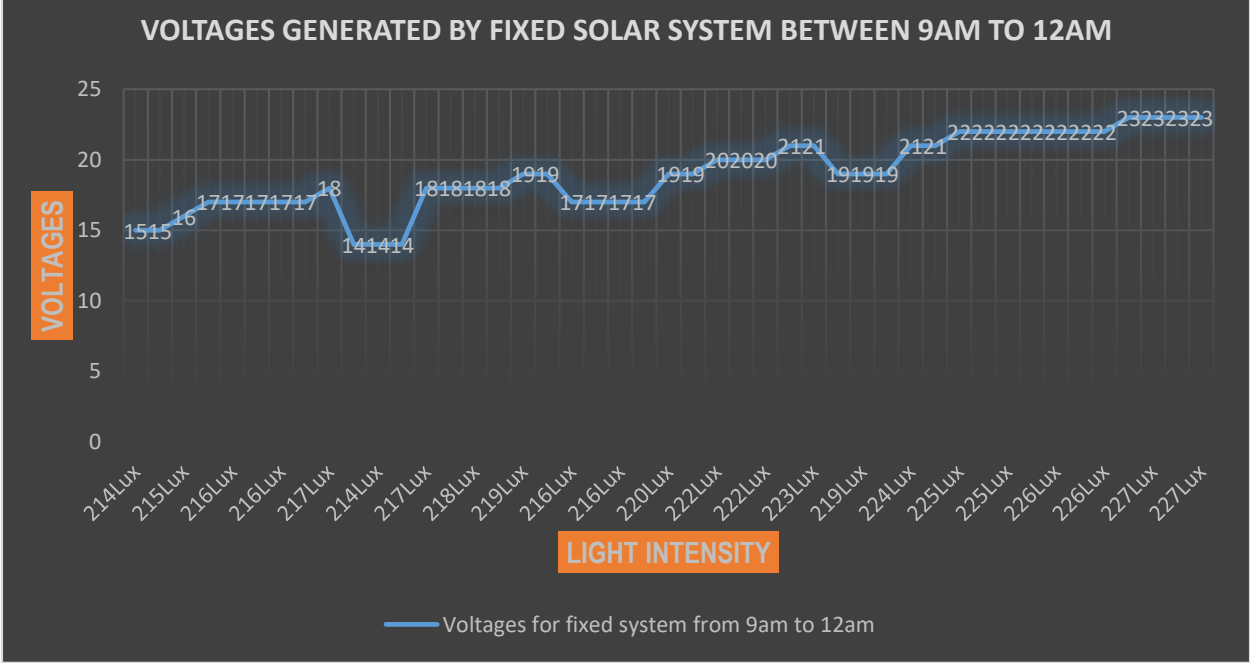

$$\sum_i^n xi=1360$$

$$X = \frac{\sum_i^n xi}{n} = \frac{1360}{45}$$

$$X=30.22v$$

The average of the data captured by the rotating solar system calculations is 30.22v. This means that for the period of measurement, all the recorded voltage values added and then divided by the number of measurements gave an average voltage of 30.22Volts. This value gives a benchmark of the typical performance level of the solar system within the given period and thus helps in assessing how efficient and consistent the voltage generation by the system has been.

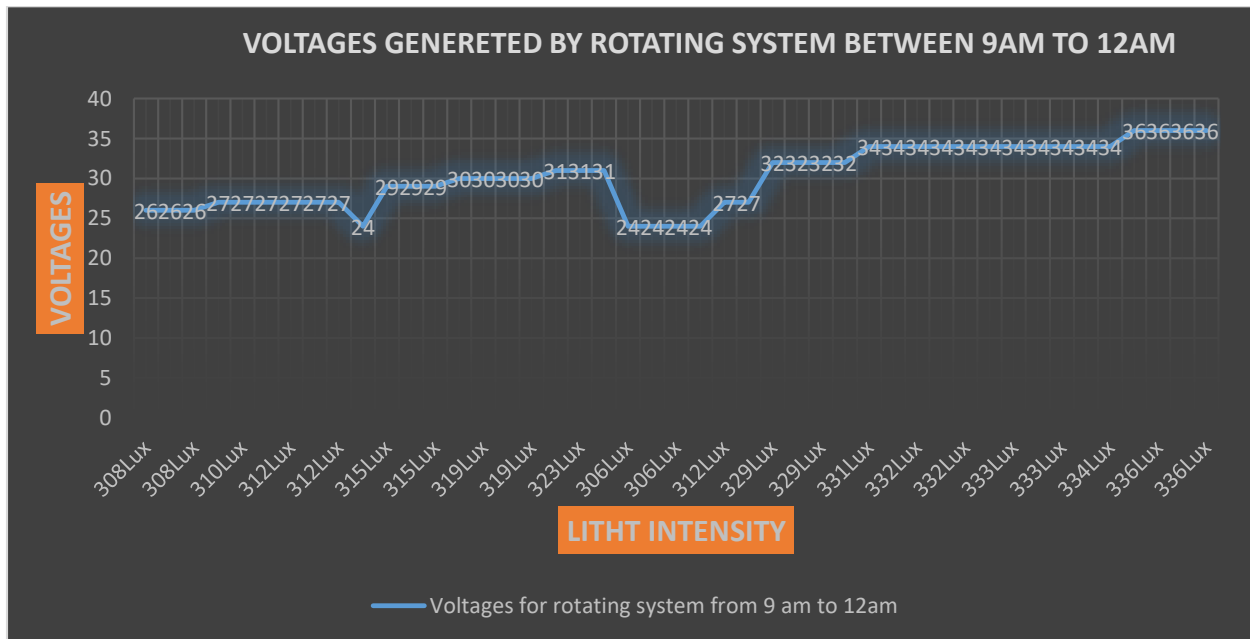

Figure 5.5: Voltages generated by rotating system from 9am to 12am

The figure 5.5 indicates changes in data captured by rotating solar system over time. This graph presentation gives an easy way of establishing how the performance of the solar system changes over the day. The chart increases in voltage values as the sunlight intensifies in the morning, peaks the mid values at midday when the sun is at its highest, and gradual decrease in the afternoon as sunlight diminishes.

Voltages Comparison

Comparing the fixed and rotating solar systems, there is an evident voltage generation difference between 9 am and 12 am on both solar systems, with the morning hours still relatively weak in light intensity of the sun. The fixed solar system produced an average of 18.97v during these 3 hours, whereas the rotating system was tracking the movement of the sun, reaching 30.22 v average, so high. This implies that the voltage output difference between the two systems is an 11.25v, which highlights how the rotating system better captures sunlight and reformats it into energy when the light intensity is not so ideal. This is a sign that the rotating system maximizes on energy production with better tracking for optimization on alignment to the sun, hence bettering the fixed system to harness available solar power at this time.

5.1.4 Statistical analysis fixed Solar system from 12pm to 3pm

As data have captured during the day, data have analyzed statistically to get the mean. To calculate the mean of voltages captured during the day by fixed solar systems, we sum all the data points recorded during these hours and divide number of hours. Let say that data points are $x_1, x_2, x_3 + \dots x_{45}$

Mathematically, this expressed as Mean = $\frac{x_1+x_2+x_3+\dots+x_{45}}{n}$

$$\sum_i^n x_i = 1815$$

$$X = \sum_i^n \frac{x_i}{n} = \frac{1815}{45}$$

$$X = 40.33v$$

The average of the data captured by the fixed solar system calculations is 40.33v. This means that for the period of measurement, all the recorded voltage values added and then divided by the number of measurements gave an average voltage of 40.33Volts. This value gives a benchmark of the typical performance level of the solar system within the given period and thus helps in assessing how efficient and consistent the voltage generation by the system has been.

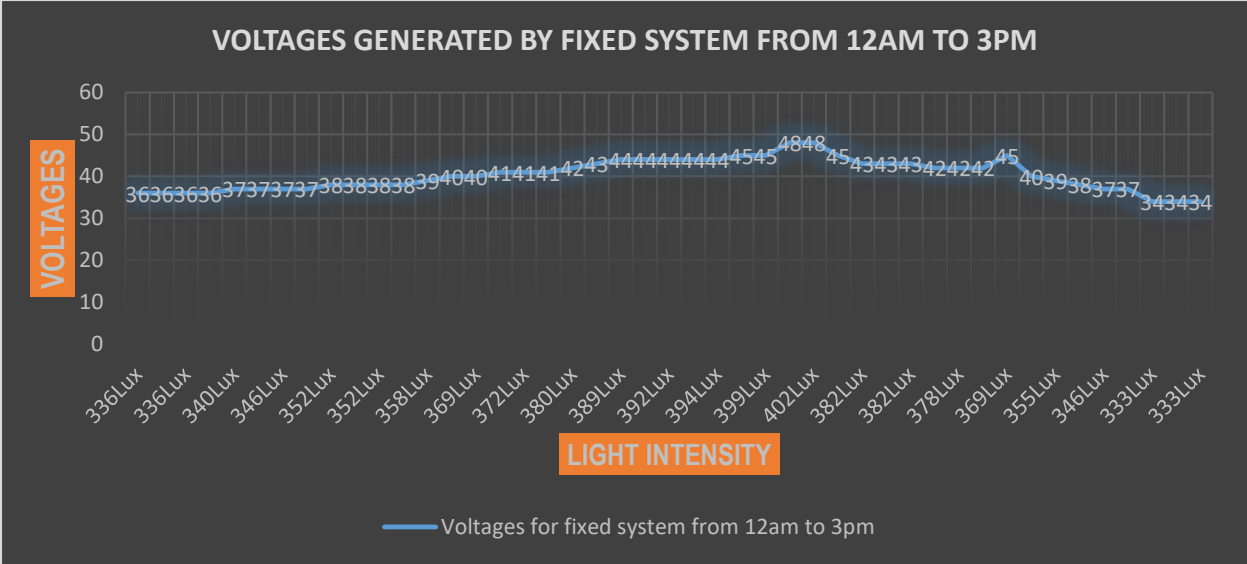

Figure 5.6: Voltages generated by fixed system from 12am to 3pm

The figure 5.6 indicates changes in data captured by rotating solar system over time. This graph presentation gives an easy way of establishing how the performance of the solar system changes over the day. The chart increases in voltage values as the sunlight intensifies in the morning, peaks the mid values at midday when the sun is at its highest, and gradual decrease in the afternoon as sunlight diminishes.

5.1.4 Statistical analysis rotating Solar system from 12am to 3am

As data have captured during the day, data have analyzed statistically to get the mean. To calculate the mean of voltages captured during the day by rotating solar system from 12 am to 3am, we sum all the data points recorded during these hours and divide number of hours. Let say that data points are $x_1, x_2, x_3 + \dots x_{45}$

Mathematically, this expressed as $Mean = \frac{x_1+x_2+x_3+\dots+x_{45}}{n}$

$\sum_i^n xi=2023$

$X = \sum_i^n \frac{xi}{n} = \frac{2023}{45}$

$X=44.95v$

The average of the data captured by the fixed solar system calculations is 44.95v. This means that for the period of measurement, all the recorded voltage values added and then divided by the

number of measurements gave an average voltage of 44.95Volts. This value gives a benchmark of the typical performance level of the solar system within the given period and thus helps in assessing how efficient and consistent the voltage generation by the system has been.

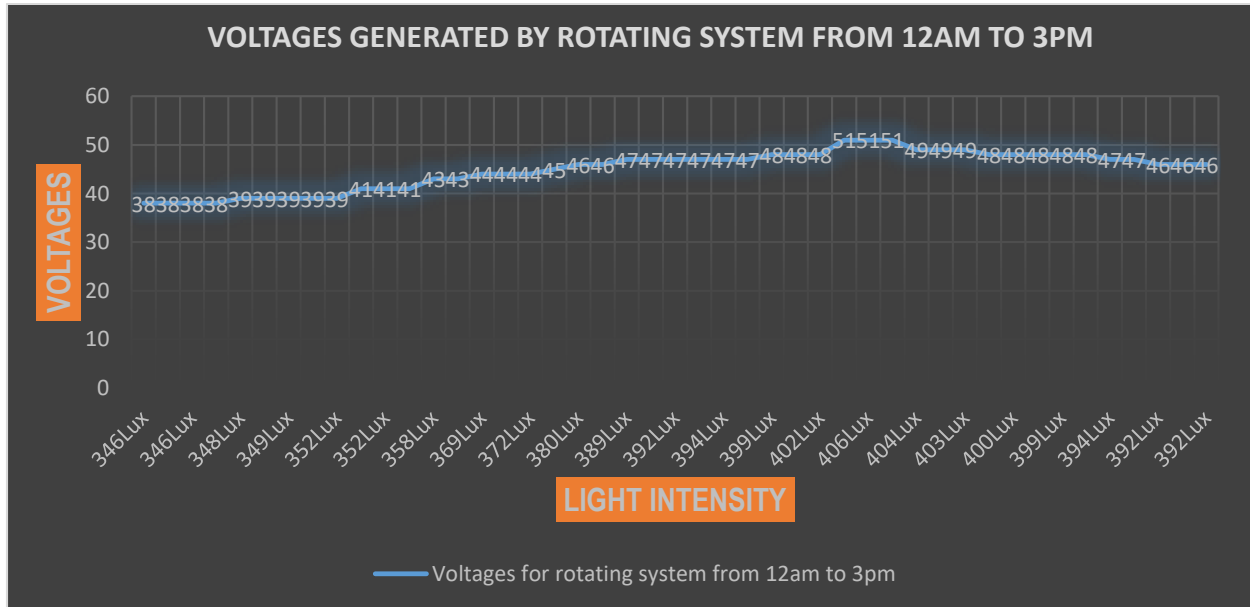

Figure 5.7: Voltages generated by rotating solar system from 12am to 3pm

The figure 5.3 indicates changes in data captured by rotating solar system over time. This graph presentation gives an easy way of establishing how the performance of the solar system changes over the day. The chart increases in voltage values as the sunlight intensifies in the morning, peaks the mid values at midday when the sun is at its highest, and gradual decrease in the afternoon as sunlight diminishes.

Voltages comparison

Comparing voltages obtained from both fixed and rotating solar systems in the time frame between 12 am and 3 pm shows that they were producing higher voltages compared to the earlier hours of the day; they were also being affected by the weak solar light intensity during the morning hours. In this case, the fixed solar system averaged 40.33 volts, whereas the rotating system, self-aligning with respect to the position of the sun, was generating an average of 44.95 volts. The voltage between the fixed and rotating systems amounts to 4.62 volts. This is reinforcing the conclusions drawn so far that the rotating system has outperformed the fixed system by better optimization of sunlight. This difference reflects the possibility that the rotating system is better aligned with the sun and, therefore, even with the progress of the day, it will be more effective in conversion.

5.1.4 Statistical analysis fixed Solar system from 3pm to 6pm

As data have captured during the day, data have analyzed statistically to get the mean. To calculate the mean of voltages captured during the day by fixed solar systems, we sum all the data points recorded during these hours and divide number of hours. Let say that data points are $x_1, x_2, x_3 + \dots x_{45}$

Mathematically, this expressed as Mean =
$$\frac{x_1+x_2+x_3+\dots+x_{45}}{n}$$

$$\sum_i^n xi=912$$

$$X = \sum_i^n \frac{xi}{n} = \frac{912}{45}$$

$$X=20.26v$$

The average of the data captured by the fixed solar system from 3pm to 6pm is 20.26v. This means that for the period of measurement, all the recorded voltage values added and then divided by the number of measurements gave an average voltage of 20.26Volts. This value gives a benchmark of the typical performance level of the solar system within the given period and thus helps in assessing how efficient and consistent the voltage generation by the system has been.

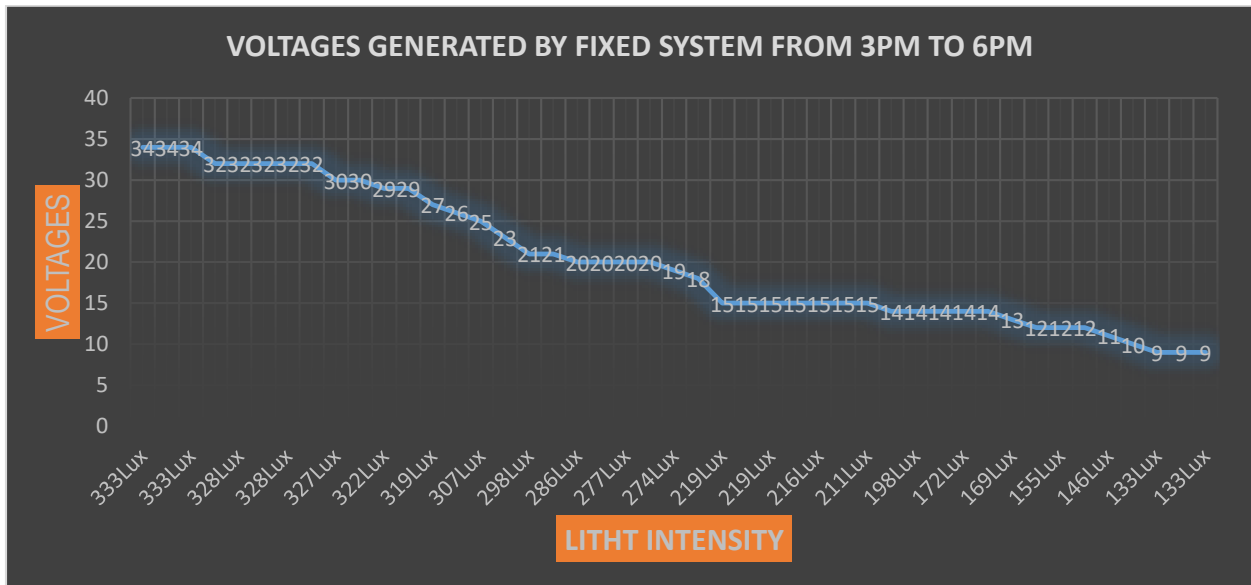

Figure 5.8: Voltages generated by fixed system from 3pm to 6pm

The figure 5.3 indicates changes in data captured by rotating solar system over time. This graph presentation gives an easy way of establishing how the performance of the solar system changes over the day. The chart increases in voltage values as the sunlight intensifies in the morning, peaks the mid values at midday when the sun is at its highest, and gradual decrease in the afternoon as sunlight diminishes.

5.1.4 Statistical analysis rotating Solar system from 3pm to 6pm

As data have captured during the day, data have analyzed statistically to get the mean. To calculate the mean of voltages captured during the day by fixed solar systems, we sum all the data points recorded during these hours and divide number of hours. Let say that data points are $x_1, x_2, x_3 + \dots x_{45}$

Mathematically, this expressed as Mean = $\frac{x_1+x_2+x_3+\dots+x_{45}}{n}$

$$\sum_i^n xi=1399$$

$$X = \sum_i^n \frac{xi}{n} = \frac{1399}{45}$$

$$X=31.98v$$

The average of the data captured by the rotating solar system from 3pm to 6pm is 31.98v. This means that for the period of measurement, all the recorded voltage values added and then divided by the number of measurements gave an average voltage of 31.98Volts. This value gives a benchmark of the typical performance level of the solar system within the given period and thus helps in assessing how efficient and consistent the voltage generation by the system has been.

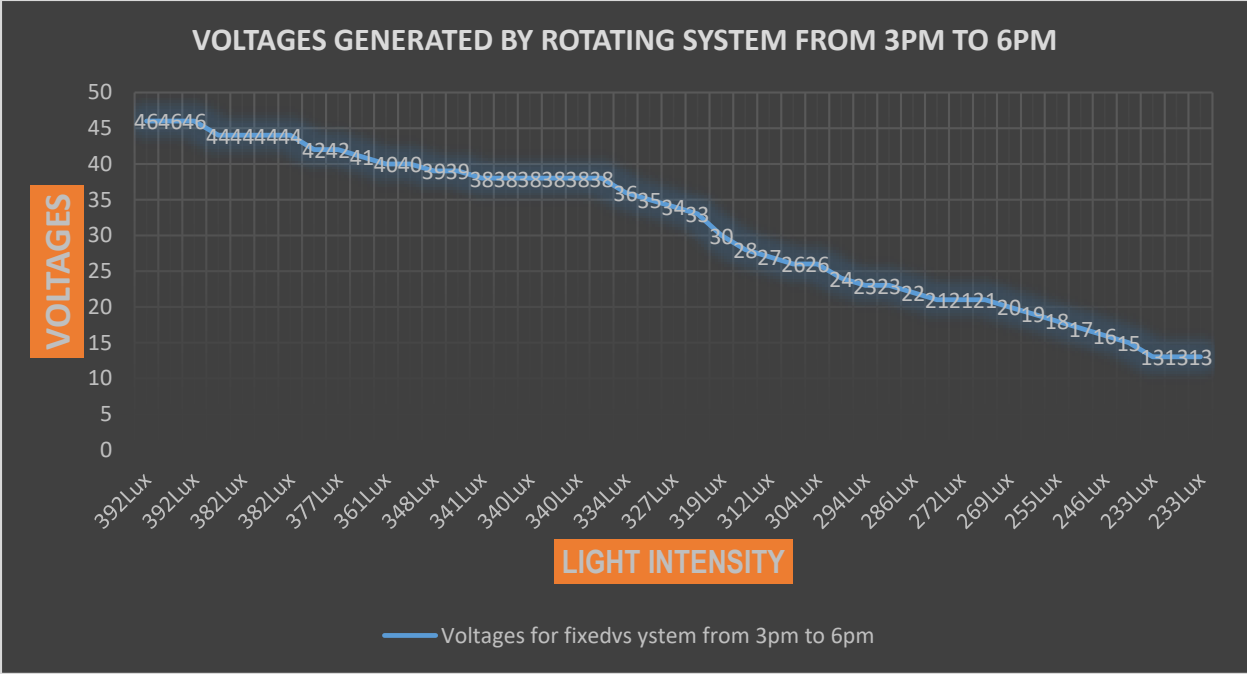

Figure 5.3: Voltages generated by rotating system from 3pm to 6pm

The figure 5.3 indicates changes in data captured by rotating solar system over time. This graph presentation gives an easy way of establishing how the performance of the solar system changes over the day. The chart increases in voltage values as the sunlight intensifies in the morning, peaks the mid values at midday when the sun is at its highest, and gradual decrease in the afternoon as sunlight diminishes.

Voltages Comparison

The plot for voltage generation from 3 pm to 6 pm between the fixed and rotating solar systems brings into light the sharp contrasts in performance for the two systems. For the three hours, the fixed solar system will have generated an average voltage of 20.26 volts while its counterpart, the rotating system, which changes position in pursuit of the sun, generates an average voltage of 31.98 volts. This voltage difference of 11.72 volts points out that the rotating system is superior to stay ahead in sunlight capture, even when the day wears on. Both systems continued to generate lower voltages, though, due to the earlier weakness in the intensity of solar light during morning hours and its overall impact on the energy generated throughout the day.

5.1.7 Overall comparison

The general voltage generation comparison for the fixed and rotating solar systems over a period starting from 6 am to 6 pm is shown below. It has been noticed that the rotating system has an advantage over the fixed system in harnessing more solar energy. During the early morning hours-from 6 am to 9 am-the voltage generated by the fixed solar system was 10.24 volts, while that for the rotating system was 11.73 volts, with a difference of 1.49 volts. That early difference between the two systems reflects the rotating system's ability to capture more sunlight despite the weak morning light. From 9 am going into 12 am, when the sun's intensity increased, it produced 18.97 volts in the fixed system, while the rotating system surpassed that with a high of 30.22 volts and was higher by as much as 11.25 volts. That wide margin shows that the rotating system has a good tracking capability, where it optimizes sunlight absorption while facing the position of the sun. Now, from 12 pm to 3 pm, when the sunlight is at its peak, the fixed solar system produced 40.33 volts and the rotating one produced 44.95 volts, amounting to a difference of 4.62 volts. The rotating system kept its lead even into peak hours, albeit with a closer difference. Starting at 3 pm to 6 pm, when the intensity of light started getting less, the fixed system generated 20.26 volts of voltage while the rotating system still provided a good 31.98 volts thus creating an 11.72-volt difference. The total voltage produced in that period is 29.08 volts, an excellent performance by the rotating system all day. Both systems, though, were also subject to weaker light during morning and evening, reflecting somewhat lower voltage output compared with peak conditions.

5.1.8 Error margin

The error margin in this research could differ based on various factors, such as the accuracy of measuring instruments, environmental conditions, and uniformity in the fixation of the solar panels. An error margin of 2-5% could normally be allowed in such studies, but it would go higher if there are considerable variations in weather, shading, or accuracy of alignment. Such an error margin can only be minimized by proper calibration of equipment, controlled test conditions, and repetition of measurements.

5.1.9 Discussion

A very clear contrast in voltage generation can be observed between fixed and rotating solar systems, with the latter almost always outperforming the former at any moment in the day. As it has the capability of tracking the sun, there is a difference of 29.08 volts in the total currents generated over that whole period, i.e., 6 am to 6 pm. This overall difference is a strong indication that this rotating system captures solar energy more efficiently because it follows the sun's angle optimally and continuously absorbs much sunlight, despite the apparent changes in the sun's position. Whereas, in the case of the fixed system, it does not change its orientation and therefore captures much less energy than is available for energy conversion, for experience particularly at those times of the day when the sun is not exactly overhead.

The production of voltage difference is more present in this generation during noon when the sun could be considered highest in the sky and the intensity of the light biggest. Even in the morning and late afternoon when the intensities are weak, the rotating system produces considerably higher voltage than what the fixed system produces. It is also explained by the ability of the rotating system to adjust to varying light conditions and always be directed more directly at sunlight exposure. On the whole, all these results clearly show that a rotating solar system capable of changing its positioning in correspondence with the sun is more efficient and effective in general solar energy generation and even more so in environments where any given opportunity of capturing energy is important.

CHAPTER 6: CONCLUSION AND RECOMMENDATION

6.1 Conclusion

This research shows that IoT-enhanced rotating solar systems far outperform the fixed solar system in terms of voltage generation, thus solving a huge problem of inefficient energy capture integral in static panels. The objectives of this study were to quantify the difference between these two systems with regard to voltage output and to assess the impact IoT-based automation has on energy efficiency. The comparison curve of voltage generated between the fixed and rotating solar systems should have clearly indicated that the performance of the rotating solar system is better during the entire day. In a general way, it can be seen that in the early morning hours from 6:00 to 9:00, while the intensity of the sun is low, the voltage generation from the rotating solar system is higher by around 14.5% compared with the fixed system. In comparison to the latter, this difference will be augmented as time advances. Average output of the rotating system has been approximately 59.1% more than the fixed system in operation from 9 am to 12 pm. This voltage output increase displays a further increased ability of the rotating system to capture and convert solar energy as sunlight intensifies.

This benefit extended to the noon period, where the rotating system generated 11.5% more voltages in the time frame of 12 pm to 3 pm. This is better illustrated by the performance that was generally realized during the day. The rotating solar system generally generated 24.06 volts on average per hour, which is 26.6% higher than the fixed solar system that generated 19 volts per hour on average. This indicates a constant rise in voltage output—from 14.5% when the sun is low to 59.1% during peak sun—and is an indication of the efficiency of the rotating system at its best for the capture and conversion of energy. This work hence reveals that the rotation of solar panels does provide substantial enhancement in voltage generation compared to fixed panels, thus providing a better means for the optimization of utilization of solar energy.

6.2 Recommendations

Project is great way to learn by practice knowledge and skills that got from theory, project should facilitated students to know and to understand that basically needs in the society and on market place therefore recommendations go to students who want to do any project to think twice about the society needs, in order to search and find the solution that facilitate society and in their daily issues, recommendations go to owner of solar panel plants and to the University of Rwanda.

6.2.1 To owners of Solar power plants

Based on the results got from comparison of fixed solar tracking system and rotating solar tracking system have shown that rotating solar tracking system is more productive than fixed one in terms of voltage generating. Therefore, researcher recommended the owners of solar power plant systems to use rotating tracking system in order to maximize exploitation of solar energy and to increase production.

6.2.2 To the University of Rwanda

During the design and implementation of this project, some components to be used were expensive therefore researcher recommends University of Rwanda to increase research fund to researchers and to help researchers to meet with industries where project like this one can work and serve society.

6.2.3 To the government of Rwanda

Research would like to recommend the government of Rwanda to support this project due its impact on solar power plant productivity. Based on the results obtained in this study, this project will increase the production of the solar power plant in terms of voltage generating. This project will help owners of solar plant systems to maximize energy from sunlight.

6.2.4 To future researchers

Recommendation to the next researchers to continue to work on this project mainly to focus on the following features:

- To remotely control a solar panel using mobile application

REFERENCES

1. Alharthi, Y. Z., Siddiki, M. K., & Chaudhry, G. M. (2018). Economic Analysis and Environmental Impacts of a Hybrid PV System in Arid Climate Considering Different Types of Solar Trackers. *Smart Grid and Renewable Energy*, 09(10), 199–214. <https://doi.org/10.4236/sgre.2018.910013>
2. Amalia Yunia Rahmawati. (2020). 濟無No Title No Title No Title (Issue July).
3. El Hammoumi, A., Motahhir, S., El Ghzizal, A., & Derouich, A. (2021). Internet of Things-Based Solar Tracker System. *Green Energy and Technology*, June, 75–95. https://doi.org/10.1007/978-3-030-64565-6_4
4. Gafurov, K., & Chung, T. M. (2019). Comprehensive survey on internet of things, architecture, security aspects, applications, related technologies, economic perspective, and future directions. *Journal of Information Processing Systems*, 15(4), 797–819. <https://doi.org/10.3745/JIPS.03.0125>
5. Haidar, A. M., Benachaiba, C., Zahir, M., Haidar, A. M., Benachaiba, C., Zahir, M., & Haidar, A. M. A. (2013). Software interfacing of servo motor with microcontroller Software interfacing of servo motor with microcontroller Software interfacing of servo motor with microcontroller Software interfacing of servo motor with microcontroller Publication Details Publication Details "Software interfacing of servo motor with microcontroller. *Journal of Electrical Systems*, 9(1), 84–99. <https://ro.uow.edu.au/eispapers>:<https://ro.uow.edu.au/eispapers/468>
6. Hester, S. B., & Yuen, M. (2010). 21-04-2010 <Http://Www.Acrwebsite.Org/Volumes/Dis....> In *Advances in Consumer Research* (Vol. 02, Issue 1975).
7. Jafri, M., Yadav, A., Srivastava, A., Kumar, D., & Thapa, V. (2023). *IOT Based Solar Tracking and Cleaning System*. 10(1), 118–122.
8. Jin, X., Xu, G., Zhou, R., Luo, X., & Quan, Y. (2013). A Sun Tracking System Design for a Large Dish Solar Concentrator. *International Journal of Clean Coal and Energy*, 02(02), 16–20. <https://doi.org/10.4236/ijcce.2013.22b004>
9. Kumbhar, V. K., Chougule, N. K., Gangdhar, P. L., Patil, V. T., Deshmukh, A. S., &

- Gaikwad, R. S. (2021). Iot Based Solar Tracking and Monitoring System. *International Research Journal of Modernization in Engineering Technology and Science*, 05, 2582–5208. www.irjmets.com
10. Lewandoski, C. F., Santos, R. F., Man Kit Sio, J. P., Almeida, M. de, & Ikpehai, A. (2021). The Advantages of Solar Tracker. *International Journal of Environmental Resilience Research and Science*, 3(1), 31–46. <https://e-revista.unioeste.br/index.php/ijerrs/article/view/26451/16986>
 11. Maiga, A. (2021). Theoretical Comparative Energy Efficiency Analysis of Dual Axis Solar Tracking Systems. *Energy and Power Engineering*, 13(12), 448–482. <https://doi.org/10.4236/epe.2021.1312031>
 12. Maqbool, R., & Akubo, S. A. (2022). Solar energy for sustainability in Africa: The challenges of socio-economic factors and technical complexities. *International Journal of Energy Research*, 46(12), 16336–16354. <https://doi.org/10.1002/er.8425>
 13. Minu, O., Ramsiya, M., Thasini, A., Narayanan, K. V., & Arun, K. (2020). Forest Fire Detection and Alerting System. *International Journal of Research in Engineering, Science and Management*, 5, 8–10.
 14. Mohan, H. M., Nair, A. M., Chandran, A. B., Anuraj, P., & Chandran, A. B. (2019). *Solar Powered Plug-in Electric Vehicle*. 8(05), 968–971.
 15. Parveen, R., Mohammed, A., of, K. R.-I. J., & 2018, undefined. (2018). IoT based solar tracking system for efficient power generation. *Ijrar.Org*, 5(04), 481–485. <https://www.ijrar.org/papers/IJRAR1944279.pdf>
 16. Rahmayani, A., & Jakarta, P. N. (2019). *Smart Lighting Prototypes for Deaf Disabled People Smart Lighting Prototypes for Deaf Disabled People*. July. <https://doi.org/10.13140/RG.2.2.29819.87840>
 17. Renewable, P., & Programme, E. (2014). Access to Energy in Rwanda. *IOB Evaluation*, 396, 58. [https://policycommons.net/artifacts/1334631/access-to-energy-in-developing-countries/1940350/%0Ahttp://www.europarl.europa.eu/RegData/etudes/etudes/join/2011/457058/IPOL-DEVE_ET\(2011\)457058_EN.pdf](https://policycommons.net/artifacts/1334631/access-to-energy-in-developing-countries/1940350/%0Ahttp://www.europarl.europa.eu/RegData/etudes/etudes/join/2011/457058/IPOL-DEVE_ET(2011)457058_EN.pdf)
 18. Rizk, J., & Chaiko, Y. (2008). Solar Tracking System: More Efficient Use of Solar Panels. *Proceedings of World Academy of Science: Engineering & Technology*, 43, 313–315.
 19. Sudhan, R. H., Kumar, M. G., Prakash, A. U., Devi, S. A. R., & P., S. (2015). Arduino

Atmega-328 Microcontroller. *Ijireeice*, 3(4), 27–29.
<https://doi.org/10.17148/ijireeice.2015.3406>

20. Us, A., Journals, B., & Us, C. (n.d.). *Power Hour-An IoT Based Energy Efficient Solar Tracking System*. <https://doi.org/10.4172/2325-9809.1000255>
21. Vinodhkumar, R., & John, S. (2020). IoT based dual-axis solar tracking system. *IOP Conference Series: Materials Science and Engineering*, 912(3).
<https://doi.org/10.1088/1757-899X/912/3/032024>